

Operating Instructions & Parts Manual

Please read and save these instructions. Read carefully before attempting to assemble, install, operate or maintain the product described. Protect yourself and others by observing all safety information. Failure to comply with instructions could result in personal injury and/or property damage! Retain instructions for future reference.

Artesian Drive®

Centrifugal Constant Pressure Control

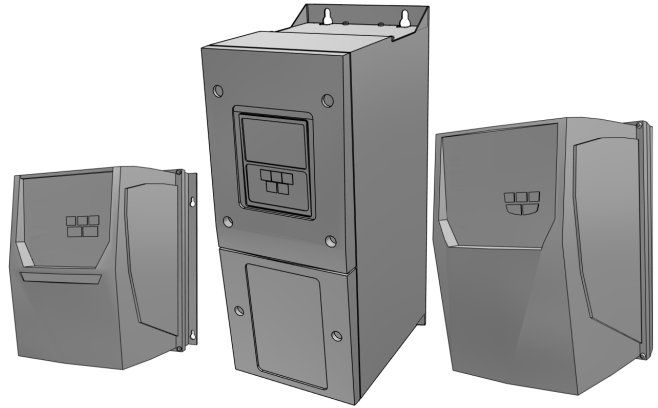

Models (All Artesian Drives) AD070059, AD096074, AD096096, AD150145, AD420210, AD180145, AD220210, AD280280, AD420410

Descriptions and Features

The F&W Artesian Drive is a dependable water system Variable Frequency Drive (VFD) that uses custom programming to enhance the performance of standard centrifugal pumps. When applied correctly to three phase motor driven pumps, the Artesian Drive eliminates pressure cycling associated with conventional pressure switch controlled water pumping systems and provides a constant output pressure.

KEY FEATURES OF THE ARTESIAN DRIVE INCLUDE:

- Constant water pressure with a wide range of settings (15-95 psi) (Note: The maximum obtainable system pressure is limited by the performance of the pump installed)
- Smaller pressure tank can be used
- Fits the pump to the application – pump speed is controlled to provide the optimum performance without overloading the motor
- Flexibility – you can use this unit with standard off-the-shelf pumps and 3-Phase motors
- No in-rush (power-on transient) current
- Protection features
 - Dry run conditions – using intelligent load monitoring (see Page 7)
 - High voltage / lightning surge
 - Low line voltage
 - Short circuit

Unpacking

When unpacking the unit, inspect carefully for any damage that may have occurred during transit.

Included Items:

A. Controller Unit	E. Warranty Card
B. Strain Relief Fitting	F. Installation Guide
C. Pressure Transducer	G. Installation Manual
D. Transducer Cable	

General Safety Information

Carefully read and follow all safety instructions in this manual and on pump. Keep safety labels in good condition. Replace missing or damaged safety labels.

 **This is a SAFETY ALERT SYMBOL. When you see this symbol on the pump or in the manual, look for one of the following signal words and be alert to the potential for personal injury or property damage.**

DANGER Warns of hazards that WILL cause serious personal injury, death or major property damage if ignored.

WARNING Warns of hazards that CAN cause serious personal injury or death, if ignored.

CAUTION Warns of hazards that MAY cause minor personal injury, product or property damage if ignored.

IMPORTANT: Indicates factors concerned with operation, installation, assembly or maintenance which could result in damage to the machine or equipment if ignored.

NOTE: Indicates special instructions which are important but are not related to hazards.

WARNING Read these warnings and instructions carefully. Failure to follow could result in serious bodily injury and/or property damage.

WARNING Capacitors inside the Artesian Drive controller can still hold a lethal voltage even after power has been removed. Allow 5 minutes for dangerous internal voltage to discharge before opening the unit.

CAUTION Do not use power factor correction capacitors with the Artesian Drive. Damage will result to both motor and drive.

 **WARNING** Electrical installations shall be in accordance with National Electric Code (NEC) and all applicable local codes and ordinances. A licensed electrician should perform installation.



⚠ WARNING Be sure system is connected to a circuit equipped with a fuse or circuit breaker of the correct rating.



⚠ DANGER Always disconnect power source before performing any work on or near the controller, motor or its connected load. If the power disconnect point is out-of-sight, lock it in the open position and/or tag it to prevent unexpected application of power. Failure to do so could result in fatal electrical shock or bodily injury.



⚠ DANGER DO NOT handle pump with wet hands or when standing in water as fatal electrical shock could occur. Disconnect main power supply before handling system for any reason.



⚠ WARNING Protect the power cable from coming in contact with sharp objects, oil, grease, hot surfaces or chemicals. DO NOT kink the power cable. If damaged replace immediately.



⚠ WARNING NEVER leave the control box, fused disconnect switch, or covers open (either partially or completely) when not being worked on by a competent electrician or repairman.



⚠ DANGER Always use caution when operating electrical controls in damp areas. If possible, avoid all contact with electrical equipment during thunderstorms or extreme damp conditions.



⚠ WARNING Install all electrical equipment in protected area to prevent mechanical damage which could produce serious electrical shock and/or equipment failure.



⚠ DANGER DO NOT use this system to pump flammable liquids such as gasoline, fuel oil, kerosene, etc. Failure to follow the above warning could result in property damage and/or personal injury.



⚠ WARNING Prop65 Warning for California residents:



⚠ WARNING: Cancer and Reproductive Harm - www.P65Warnings.ca.gov



⚠ CAUTION Do not pump water above 140 degrees Fahrenheit.



⚠ WARNING This unit not tested for use in swimming pool areas.

How it Works

The F&W Artesian Drive is designed to be part of a system that consists of only four major components:

- Standard Pump and Three Phase Motor.
- Artesian Drive Controller.
- Small Pressure Tank (for tank size, see Table 2).
- Pressure Transducer (provided).

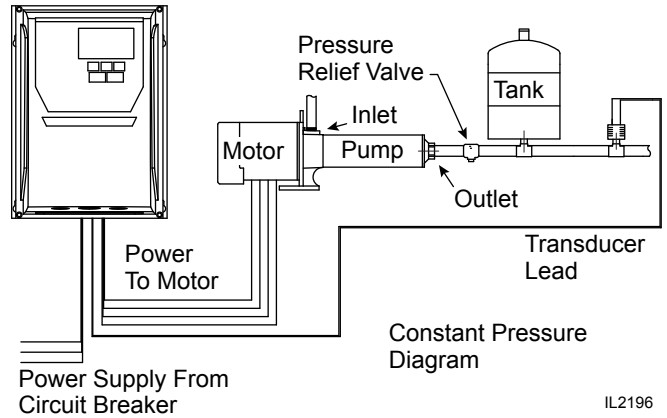

Figure 2a - Constant Pressure Diagram for booster pumps

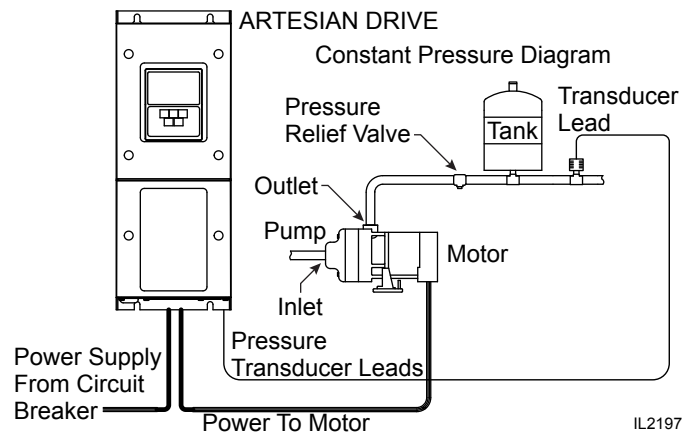

Figure 2b - Constant Pressure Diagram for centrifugal pumps

Constant Pressure

The F&W Artesian Drive provides consistent pressure regulation using custom programming to run a standard motor and pump according to the pressure demands indicated by a heavy duty pressure switch. By adjusting the motor/pump speed, the Artesian Drive can deliver consistent pressure dependably, even as water demand changes. For example, a small demand on the system, such as a kitchen faucet, results in the motor/pump running at a relatively low speed. As greater demands are placed on the water system, such as opening additional faucets or using appliances, the motor/pump speed increases accordingly to maintain the desired system pressure.

MOTOR SOFT START

Whenever the Artesian Drive detects that water is being used, the controller always "ramps up" the motor speed at the same time as gradually increasing voltage, resulting in a cooler running motor and lower in-rush current compared to a motor being used on conventional water systems. If the water demand is very low, the system may cycle on and off at very low speeds, but due to the drive's soft-start feature and pressure switch's dependable design, this will not harm the motor or the transducer.

SYSTEM DIAGNOSTICS

In addition to regulating system pressure and accurately controlling motor operation, the Artesian Drive continuously scans the system and can detect a variety of abnormal conditions. If there is elevated risk of damage to a part of

the system, the drive will protect the system and display a code for the fault. If possible, the drive will try to restart itself when the fault condition passes.

PUMP SIZING – ARTESIAN DRIVE (CENTRIFUGAL)

The Artesian Drive is configured at the factory for use with standard 3-phase motors and pumps.

NOTE: The Artesian Drives are factory programmed to F&W pumps to provide optimum performance and motor protection. The Artesian Drive can be used with other pumps, but the maximum motor amperage needs to be compared to the factory programmed current value (refer to the Specifications section under the appropriate model). If the maximum motor current varies more than 5% from the programmed value, the motor current value in the drive needs to be changed for motor protection and optimum performance. See Parameter P1-08 page 8.

▲ WARNING *The motor rated current must be set correctly to avoid a risk of fire in the event of a motor overload.*

DRIVE CONFIGURATION

When sized correctly, the Artesian Drive systems are ready to go right out of the box and need no configuration. Under certain circumstances there are several programming parameters that can be changed to accommodate non standard systems. See DRIVE CONFIGURATION page 8.

▲ WARNING *Serious or fatal electrical shock may result from contact with internal electrical components. DO NOT, under any circumstances, attempt to modify connections to the drive until power has been removed and 10 minutes have passed for internal voltages to discharge!*

UNDERLOAD SENSITIVITY

The Artesian Drive controller is configured at the factory to ensure detection of Underload faults in a wide variety of pumping applications including dead head and run dry conditions. In very rare cases (as with certain pumps in shallow wells) this trip level may result in nuisance faults. If the pump is installed in a shallow well, activate the controller and observe system behavior. Once the controller begins to regulate pressure, check operation at several flow rates to make sure the default sensitivity does not induce nuisance Underload trips. If it becomes necessary to desensitize the Underload trip level, refer to DRIVE CONFIGURATION page 8, Parameter P1-16.

▲ WARNING *Serious or fatal electrical shock may result from contact with internal electrical components. DO NOT, under any circumstances, attempt to modify connections to the drive until power has been removed and 5 minutes have passed for internal voltages to discharge!*

Before Getting Started

▲ WARNING *Serious or fatal electrical shock may result from failure to connect the ground terminal to the motor, Artesian Drive controller, metal plumbing, or other metal near the motor or cable, using wire no smaller than motor cable wires. To minimize risk of electrical shock, disconnect power before working on or around the Artesian Drive system. CAPACITORS INSIDE THE ARTESIAN DRIVE CONTROLLER CAN STILL HOLD LETHAL VOLTAGE EVEN AFTER POWER HAS BEEN DISCONNECTED. ALLOW 5 MINUTES FOR DANGEROUS INTERNAL VOLTAGE TO DISCHARGE BEFORE REMOVING ARTESIAN DRIVE COVER.*

▲ WARNING *Do not use motor or system in swimming areas.*

IMPORTANT: *This equipment should be installed by technically qualified personnel. Failure to install it in compliance with national and local electrical codes and within F&W recommendations may result in electrical shock hazard, fire hazard, unsatisfactory performance, or equipment failure.*

▲ CAUTION *Use Artesian Drive only with properly sized three phase motors. Use of this unit with improperly sized motors may result in damage to both motor and electronics.*

Controller Location Selection

The Artesian Drive controller is intended for operation in ambient temperatures up to 104°F (40°C) at 230 VAC input. The following recommendations will help in selection of the proper location of the Artesian Drive unit:

1. A tank tee is recommended for mounting the tank, transducer, pressure gauge, and pressure relief valve at one junction. If a tank tee is not used, the transducer should be located within 6 feet (1.8 meters) downstream of the pressure tank to minimize pressure fluctuations.

NOTE: There should be no elbows between the tank and transducer sensor and the tank should be between the pump and transducer.

2. The unit should be mounted on a sturdy supporting structure such as a wall or supporting post. Please take into account the weight of the unit (refer to the Specifications section under the appropriate model).
3. The electronics inside the Artesian Drive are air-cooled. Please refer to Figures 3a & 3b for correct mounting clearances.
4. The Artesian Drive should only be mounted with the wiring end oriented downward. The controller should not be placed in direct sunlight or other locations subject to extreme temperatures or humidity (mounting location should not be subjected to freezing conditions or condensation).
5. The mounting location should have access to 230 VAC electrical supply and to the pump motor wiring. To avoid possible interference with other appliances, please refer to the enclosed Installation Guide and observe all precautions regarding power cable routing.

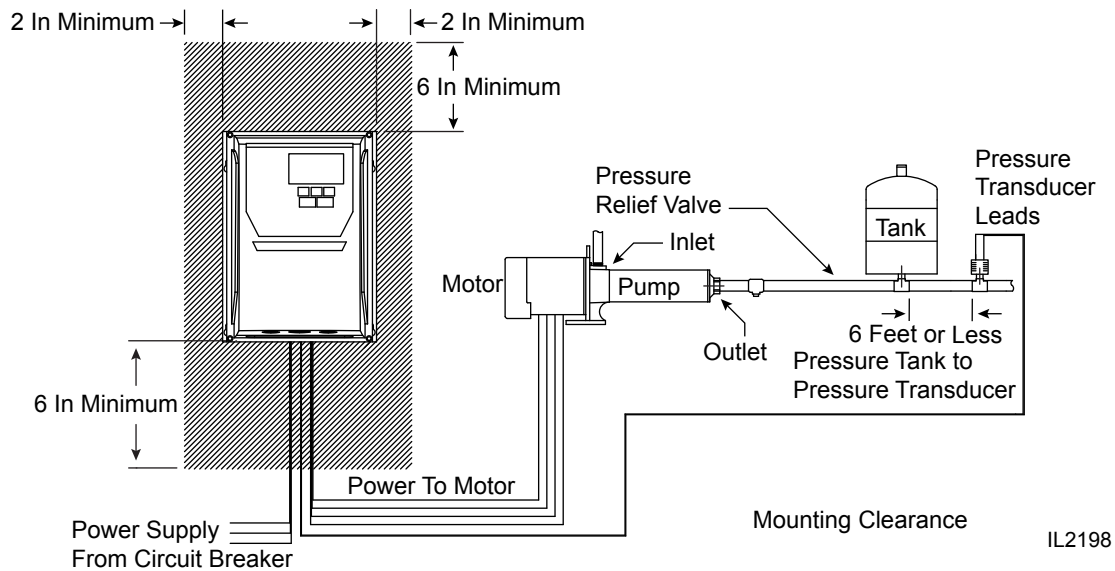

Figure 3a - Mounting Clearance - Case Style 1

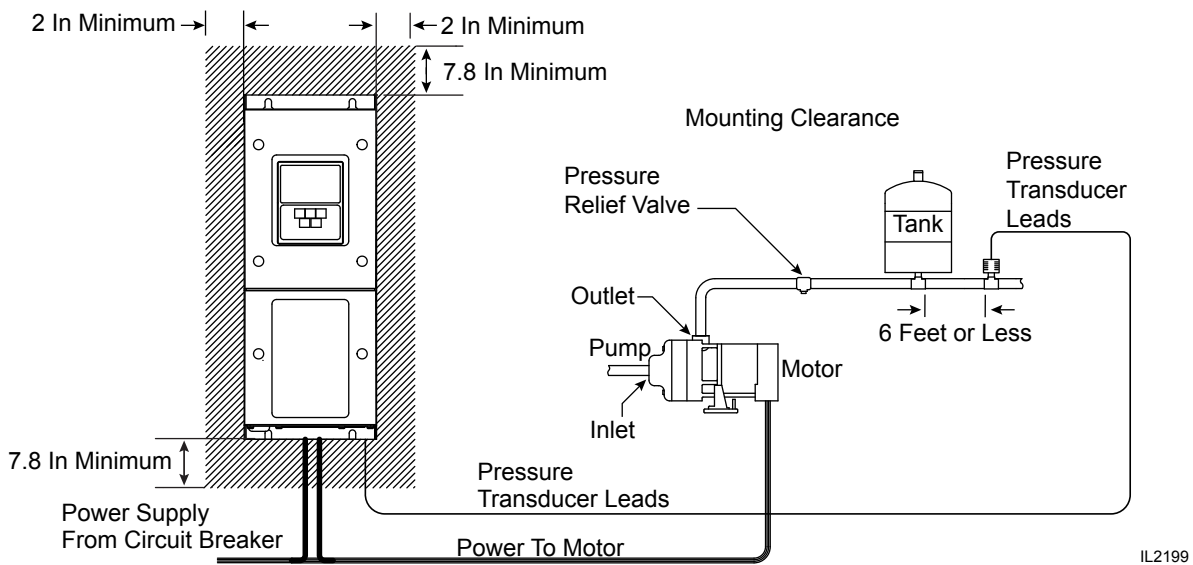

Figure 3a - Mounting Clearance - Case Style 2

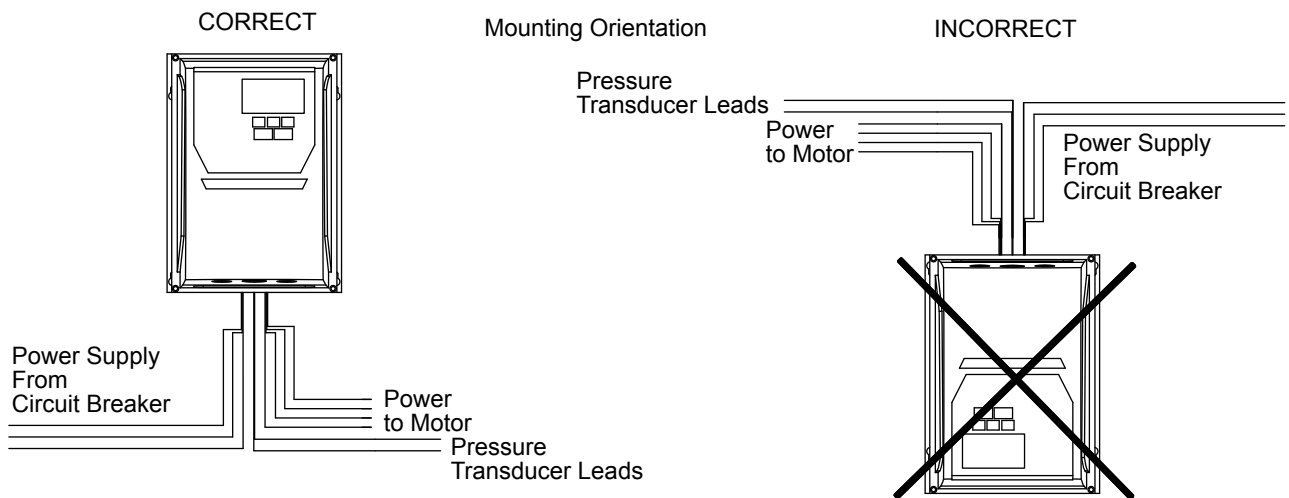

Figure 4 - Mounting Orientation

CIRCUIT BREAKER AND WIRE SIZING

The minimum circuit breaker size and maximum allowable wire lengths for connection of motor to the Artesian Drive are given in the following table:

TABLE 1: MINIMUM BREAKER SIZE AND MAXIMUM CABLE LENGTH (IN FEET)

Drive Model	Minimum Recommended Input Cable	Minimum Recommended Motor Cable	Input Current	Maximum Cable Length to Motor (Ft.)	Recommended Breaker	Maximum Continuous Current Output
AD070059	12	14	13.9	325	20	7.0
AD096074	10	14	19.5	325	30	11.0
AD096096	10	14	19.5	325	30	11.0
AD150145	8	12	36.4	325	50	15.0
AD180145	10	12	18.8	325	30	18.0
AD220210	8	10	29.1	325	40	24.0
AD420210	4	10	55.8	325	80	23.0
AD280280	8	8	36.4	325	50	30.0
AD420410	4	6	55.8	325	80	46.0

A 15-foot section of cable is provided with the Artesian Drive to connect the transducer.

NOTE:

- Maximum allowable wire lengths are measured between the controller and motor.
- Shielded cable is recommended between the motor and the controller for maximum reduction of radiated interference.
- Aluminum wires should not be used with the Artesian Drive.
- Wire sizing between the service entrance and the controller must be sufficient to provide the required maximum input amps to the controller while conforming to local standards and codes.

Pressure Tank

The Artesian Drive needs only a small pressure tank to maintain constant pressure (see table below for recommended tank size). The Artesian Drive can also use a bigger tank with a much larger capacity if available.

TABLE 2: MINIMUM PRESSURE TANK

Rated Pump Flow	Pressure Tank Size (Total Volume)
Pump Capacity less than 12 GPM	4 Gallon (AT15)
Pump Capacity greater than 12 but less than 25 GPM	8 Gallon (AT25)
Pump Capacity greater than 25 GPM	14 Gallon (AT44)

The pressure tank pre-charge setting should be 70% of the system transducer setting as indicated in the following table.

TABLE 3: PRESSURE TANK AIR PRECHARGE (PSI)

System Pressure (at Transducer)	Pressure Tank Precharge Setting (± 2 PSI)
30	21
35	25
40	28
45	32
50	35
55	39
60	42
65	46
70	49
75	53
80	56
85	59
90	63

Installation Procedure

1. Disconnect electrical power at the main breaker.
2. Drain the system of water (if applicable).
3. Install the transducer (threaded connection down) at the pressure tank tee downstream of the pressure tank (the pressure tank should be between the transducer and the pump). The transducer has a 1/4-18 National Pipe Thread (NPT) connection.

NOTE: The transducer should not be installed in an inverted orientation (threaded connection up). Make sure the transducer and tank are not located more than 3 feet off the main piping.

4. The unit should be mounted on a sturdy supporting structure such as a wall or supporting post. Please take into account the weight of the unit (refer to the Specifications section under the appropriate model). Install the unit to the wall using four mounting screws (not included) as shown in Figure 5 and Table 4 DIMENSIONS.

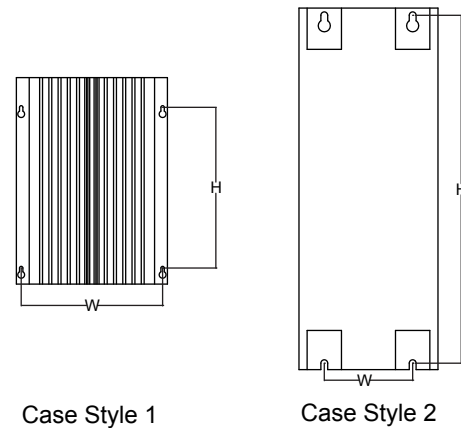

Figure 5

IL2201

TABLE 4: DIMENSIONS

Drive Model	H	W1	Case Style
AD070059, AD096074, AD096096	7-7/8"	6-15/16"	1
AD180145,	9-15/16"	7-3/4"	1
AD150145, AD220210, AD420210, AD280280, AD420410	17-1/16"	4-5/16"	2

Note: For correct motor rotation and pump performance on F&W manufactured motors, leads 1-7, 2-8 & 3-9 on the motor should be connected to U, V & W respectively. Three phase motors from other manufactures may require that connection U & V be switched at the drive for proper motor rotation and performance. For correct rotation on submersible motors the drop cable should be wired, the Red (terminal U) , Black (terminal V) & Yellow (terminal W).

For wiring convenience, the numbered terminal strip can be removed for easier wiring.

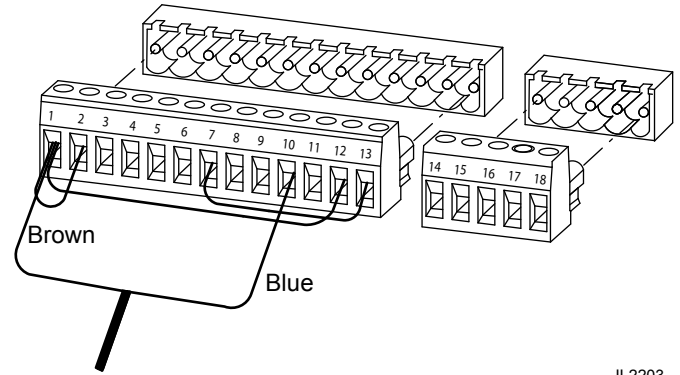

IL2203

Figure 7

7. Feed the transducer or leads through the smaller strain relief (provided) on the bottom of the Artesian Drive unit and connect the brown wire to terminal 1 and blue wire to the terminal 10. Make sure to not disconnect the factory installed jumper wires that are already connected to terminal strip. For wiring convenience, the numbered terminal strip can be removed for easier wiring.
8. Replace the Artesian Drive wiring cover on the lower section of the drive an rotating the two retaining screws 1/4 of a turn clockwise to secure.

Wiring Connections

⚠ WARNING *Serious or fatal electrical shock may result from failure to connect the motor, the Artesian Drive, metal plumbing and all other metal near the motor, or cable to the power supply ground terminal, using wire no smaller than motor cable wires. To reduce risk of electrical shock, disconnect power before working on or around the water system.*

⚠ WARNING *To avoid a fire hazard and maintain validity of the safety agency listing, torque the power terminal screws to 8.8 lb.-in. (1 N-m) for case style 1 & 35 lb.-in. (4 N-m) for case style 2.*

⚠ WARNING *Do not use motor or system in swimming areas.*

BEFORE BEGINNING WIRING

1. Verify that the power has been shut off at the main breaker.
2. Verify that the dedicated branch circuit for the Artesian Drive is equipped with a properly-sized circuit breaker. Refer to Table1 (Page 5) for minimum breaker size.
3. Remove the Artesian Drive wiring cover on the lower section of the drive by rotating the two retaining screws 1/4 of a turn counterclockwise
4. Insert correctly rated strain relief/conduit connections (not provided) into the mounting holes on the bottom of the enclosure.

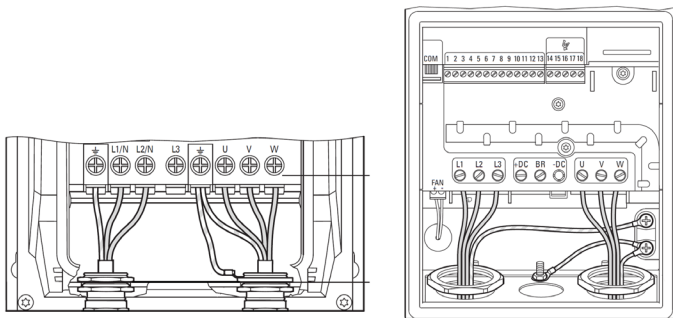
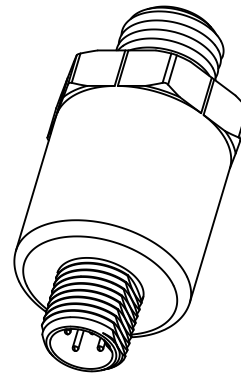

Figure 6

5. Feed the 230 VAC power leads and motor supply cable through the bottom left and right side conduit connections (not supplied) respectively. Connect the motor ground and power supply ground wires the terminals marked with the Ground Symbol.
6. Connect motor supply leads to terminals U, V and W (right hand side). Connect power leads to terminals L1 and L2 for single phase input controllers or terminals L1, L2 & L3 (left hand side).



IL1875

Figure10 - Transducer

9. Connect the free end of the transducer cable to the transducer by lining up the keyway on the connector to the transducer, pressing the cable into place & then tightening the thumbscrew finger tight.

NOTE: Ensure that the system is properly grounded all the way to the service entrance panel. Improper grounding may result in the loss of voltage surge protection and interference filtering.

Start-Up and Operation

While running the drive display shows the output frequency in Hz as well as motor amp draw and power use in kW. (Pressing and releasing the OK button toggles the large display area between the three measurements). When the drive is in standby the screen displays STOP.

NOTE: Artesian Drive maintains a constant pressure at the transducer. Although the pressure is constant at the transducer, pressure drops may be noticeable in other areas of the system when additional taps are opened. This is due to restrictions in the plumbing and will be more pronounced the farther the taps are from the transducer. This would be true of any system, and if observed, should not be interpreted as a failure in the performance of the Artesian Drive.

Although the pressure sensor can be adjusted up to 90 PSI, the maximum obtainable pressure in the system is dependent upon the full load capability of the pump at a given flow. For example, a pump is only capable of producing a pressure of 60 PSI at the flow demand. Increasing the pressure setting of the pressure sensor to 75PSI would only result in the pump running at full speed and producing a pressure of 60 PSI.

SYSTEM TARGET PRESSURE SETPOINT

The default target pressure is set at the factory to 50 PSI. To change the target system pressure, parameter P1-19 should be changed. See Drive configuration access on page 8 for details on how to access parameter changes.

UNDERLOAD INTELLIGENT RESET

(Display showing Eternal trip E-trip)

If an External Trip fault condition (underloaded motor) occurs, the most likely cause is a loss of prime, an over-pumped well (dry well), or loss of incoming feed water to the pump. In a dry well situation to allow the well to recover, the Artesian Drive controller will wait 30 seconds to 5 minutes, determined by the amount of time the motor had been running before sensing the underload, before restarting the motor. For example, the first time the fault occurs and the pump has been running 6 minutes, the controller stops the motor and will wait 30 seconds before attempting to restart the pump. If the system would then run for 2 minutes and an underload fault recurs, the controller will wait 3 minutes before attempting to restart the pump. This schedule allows for the minimum off-time possible based on the recovery time of the well or water feed supply.

If there is an obstruction (such as a closed valve) between the pump and the transducer, the controller may also sense an underload condition at this "dead head" condition stopping the motor to avoid damaging the pump.

UNDERLOAD (EXTERNAL TRIP) WHILE PRIMING

The controller will run the pump for one minute at full speed before tripping out on an underload fault, which can occur if the pump is not fully primed. If the pump needs more than one minute before priming completely, the under-load protection can be turned off by changing parameter P1-15 to 0 while the pump is priming. Remember to turn back on the underload protection by changing parameter P1-15 to 1 once the pump has been primed. See Drive configuration access on page 8 for details on how to access parameter changes.

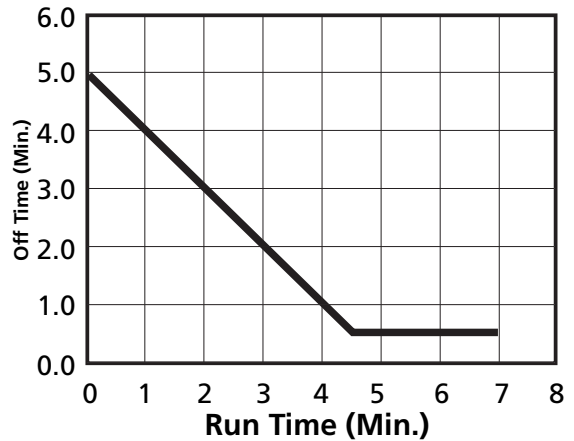

Figure 12

NOTE: The Artesian Drives are factory programmed to F&W pumps to provide optimum performance and motor protection. The Artesian Drive can be used with other pumps, but the maximum motor amperage needs to be compared to the factory programmed current value (refer to the Specifications section under the appropriate model). If the maximum motor current varies more than 5% from the programmed value, the motor current value in the drive needs to be changed for motor protection and optimum performance.

EXTERNAL SWITCH TERMINALS

If desired, an external control switch can be used to deactivate the controller & keep the pump from running. (i.e., irrigation timer switch, tank float switch, etc.) The switch must have closed contacts (normally closed) when the system is to be pumping, and the contact would then open when the pump is to be deactivated. To install a control switch, remove the factory installed jumper wire between terminals 7 & 13 and wire the control switch in it's place.

Caution: The external control must be a dry contact (i.e. no voltage applied to the terminals of the controller) to not damage the drive circuit boards. An external control with voltage can only be used with the controller if an isolation relay is used in conjunction with the voltage source. Contact technical support for more information.

DRIVE CONFIGURATION

Pressing and holding the OK button on the drive for approximately 3 seconds, will open the parameter menu access to the drive. Using the ^ & v buttons, you can scroll through the parameter. To make a change to a parameter press the OK button followed by the ^ & v buttons to set the new parameter value. Once the new value is set, press the

OK button to accept the new value. Pressing and holding the OK button on the drive for approximately 3 seconds to return to the standard run screen.

TABLE 5: PARAMETER DETAIL CHART

PARAMETER	SCREEN LABEL	NOTES
P0-09	User PID feedback	Pressure reading of transducer
P0-12	Output torque	Output torque value. At closed locked valve the standby % should be set 5-10% above this reading.
P0-13	Trip Log	Trip Log
P0-33	Run time since last trip	Amount of time elapsed since the last trip code.
P1-08	Motor rated current	Set to maximum service factor amps of the pump motor. Note: Can only be changed when the motor is not running.
P1-15	Underload Protection	Should be set to 1 to provide protection from underload conditions such as loss of prime. Set to 0 to allow pump to prime without tripping out on underload upon initial installation or after service.
P1-16	Underload %	Percent of full load at maximum speed to activate underload trip
P1-17	Standby %	When the drive is running below this % torque level and the pressure is holding steady, the drive will begin to go through the programmed logic to see if it will hold pressure when it turns off the pump. If the drive is not shutting off while pumping against a closed locked valve, this value should be changed to 5-10% above parameter P0-12 (Output torque) at the deadhead condition.
P1-19	Target Pressure	Target pressure for system in PSI. (Based on provided 100 PSI transducer) Note: If target pressure is raised, double check parameter P1-17 (Standby %) setting to verify drive will shut down with no flow.
P1-20	Drawdown PSI	Sets the amount that the system pressure has to drop below the set point while the drive is in standby before the drive will restart the motor. (Based on provided 100 PSI transducer)
P2-15	Relay 1 output function	“NC relay between terminals 14 & 16 that will Open under the conditions set: 0: Drive Running - If the drive is running the motor 1: Drive Healthy - If the drive is not tripped out 11: Ready to Run - If the drive is ready to run with jumper wire between terminals 7-13 in place 12: Drive tripped - If the drive has tripped out on a fault.”
P2-18	Relay 2 output function	“NO relay between terminals 17 & 18 that will Close under the conditions set: 0: Drive Running - If the drive is running the motor 1: Drive Healthy - If the drive is not tripped out 11: Ready to Run - If the drive is ready to run with jumper wire between terminals 7-13 in place 12: Drive tripped - If the drive has tripped out on a fault.”
P2-36	Start mode select	Sets the number of times the drive will try to re-start when it trips out on a fault.
P3-01	PID Proportional gain	Increase number for faster reaction to pressure changes. Too high of a value can cause excessive fluctuations.
P3-02	PID Integral time	Increasing value can decrease pressure overshoot. Too high of value can increase time to reach pressure setpoint.
P4-13	Output phase sequence	Used to reverse direction of the motor without having to re-wire at motor terminals. Note: Can only be changed when the motor is not running.
P6-03	Auto-reset delay	Sets the delay for time of the drive in seconds before it will auto-restart.
P6-10	PLC function enable	Should be set to 1: Enable to run the constant pressure program in the drive.

TABLE 6: FACTORY DEFAULT SETTINGS

	PARAMETER	RANGE	AD070059	AD096074	AD096096	AD150145	AD420210	AD180145	AD220210	AD280280	AD420410
P0-09	PID1 Feedback 1	0-100 %	(Read Only)								
P0-12	Output torque	0-100 %	(Read Only)								
P0-13	Trip Log		(Read Only)								
P0-33	t-Run since Trip	d:hh:mm	(Read Only)								
P1-08	Motor rated current	Drive Dependent	5.9 A	7.4 A	9.8 A	14.5 A	21.0 A	14.5 A	21.0 A	28.0 A	41.0 A
P1-15	Underload Protection	0-1	1								
P1-16	Underload %	0.0-100.0 %	65	55	55	55	50	55	50	50	50
P1-17	Standby %	0.0-100.0 %	40	30	35	35	30	35	30	30	30
P1-19	Target Pressure	50.0 psi	50.0 psi								
P1-20	Drawdown PSI	5.0 psi	5.0 psi								
P2-15	Relay 1 output function	0, 1, 11, 12	12: Drive Tripped								
P2-18	Relay 2 output function	0, 1, 11, 12	12: Drive Tripped								
P2-36	Start mode select	1, 2, 3, 4, 5, 6	60.0 Hz								
P3-01	PID Proportional gain	3.0	5: Auto-4								
P3-02	PID Integral time	1.0 s	10								
P3-18	PID reset control	0: Continuous run	5								
P4-13	Output phase sequence	0: U,V,W (1: U,W,V)	0: U,V,W								
P6-03	Auto-reset delay	1-60 s	5 s								
P6-10	PLC function enable	1: Enable (0: Disable)	1: Enable								

DIAGNOSTIC FAULT CODES

Should an application or system problem occur, built-in diagnostics will protect the system. The display will change to indicate the nature of the fault. In some cases, the system will shut itself off until corrective action has been taken. Fault

codes and the recommended corrective action for each are listed in the following chart.

▲ WARNING *Do not attempt to carry out internal repairs. Return a faulty drive to the supplier for repair.*

TABLE 7: ARTESIAN DRIVE EATON SYSTEM TRIP CODE TROUBLESHOOTING

DISPLAY FAULT	POSSIBLE CAUSE	CORRECTIVE ACTION
External Trip E-Trip	Over pumped/dry well	Wait for well to recover and automatic restart timer to time out.
	Loss of Prime	Check for suction line air leaks
	Blocked Pump Suction inlet	Clear blockage
	Broken pump shaft	Replace pump shaft (or pump)
	Broken pump shaft	Replace pump shaft (or pump)
	Damaged or inoperative transducer	Replace transducer
Under voltage U-Volt	Low line voltage	Check line voltage Report low voltage to the power company
	Power was removed from Drive	Check voltage is present on all input lines & connections secure
Motor thermal overload I.t-trP	Motor/pump mechanical failure	Examine motor and pump for mechanical failure. Replace pump or motor.
	Bound pump	Check for debris in pump
Hardware over current hO-I (or) O-I	Shorted motor cables	Check motor wires and cable for shorts or bad connections
	Shorted motor	Replace motor
	Damaged wire insulation	Check motor cable for insulation damage
	Internal hardware short	If motor is disconnected and the fault is present, replace drive.
Motor output phase loss Out-Ph	Loose connection	Check connections on drive motor terminals
	Defective splice	Check all splice connections on motor cable
	Defective cable	Check continuity of motor cable
	Open motor winding	Replace motor
4-20mA signal out of range 40-20F	Transducer lead cur or not connected properly to transducer	Check transducer lead connection and/or replace transducer lead wire.
	Loose connection on terminals 1 & 10	Check transducer lead connection at drive terminals 1 & 10
	Transducer lead wire reversed	Verify Brown & Blue transducer wires are connected to terminal 1 & 10 respectively
	Transducer failed as an open circuit	Replace transducer
Overheated O-HEAt (or) O-t	Excessive heating of the drive	Check that the ambient temperature is not above 50°C (125°F)
		Check for obstructed or inoperable fan
		Check for blocked vents
		Check mounting clearances
Low temperature U-t	Very low temperature (frost)	Verify ambient temperature is above -10°C (15°F)
Internal fan fault Fan-F	Internal cooling fan failure	Replace fan
Output fault Out-F	Drive output hardware failure	Replace drive
Warning (flashing on display)	Motor is pulling high current while running	Verify correct service factor amps are set in parameter P1-08 or reduce excessive flow demand of the pump. Note: the output frequency is reduce to prevent permanent damage to the motor.

TABLE 8: ARTESIAN DRIVE EATON TROUBLESHOOTING GUIDE

SYMPTOM	POSSIBLE CAUSE	CORRECTIVE ACTION
Water flow rate is not as high as expected	Motor/Pump is running backwards.	Reverse rotation of motor with parameter P4-13
	Pump capacity cannot supply the demand.	Use pump with higher flow rating (if head requirement is still satisfied).
Excessive pressure fluctuations	Waterlogged tank	Check tank for bladder damage. Replace if necessary.
	Incorrect tank pre-charge pressure	Reset the tank pre-charge pressure (should be 70% of target pressure setting).
	Pressure tank is too small for flow rating of the pump	Use larger tank (refer to Table X on Page X for minimum Pressure Tank size).
	Drive Control feedback settings need adjusting	Adjust parameters P3-01 & P3-02
Motor runs continuously with no flow demand	Leak in the household or outdoor plumbing	Check for leaky faucets, valves and/or pipe fittings and repair
	Standby % not set correctly	Check parameter P1-17 for correct setting compared to P0-12
Drive will not come out of standby mode	Target pressure is not set correctly	Check parameter P1-19 for correct psi setting
	Drive PLC function not enabled	Verify parameter P6-10 is set to 1
	Defective transducer	Replace defective transducer

TABLE 9: DRIVE SPECIFICATIONS AND DIMENSIONS

		AD070059	AD096074	AD096096	AD150145	AD420210	AD180145	AD220210	AD280280	AD420410	
Input from power source	Voltage	180-264 VAC Single Phase					180-264 VAC Three Phase				
	Frequency	50/60 Hz									
	Current (Max)	13.9 A	19.5 A	19.5 A	36.4 A	55.8 A	18.8 A	29.1 A	36.4 A	55.8 A	
"Output to Motor (Three Phase)"	Voltage	Voltage Automatically Adjusts with Frequency (0 thru 230 VAC)									
	Frequency Range	30-60 Hz									
	Current Programed	5.9 A	7.4 A	9.8 A	14.5 A	21.0 A	14.5 A	20.0 A	28.0 A	41.0 A	
	Current Max	7.0 A	11.0 A	11.0 A	15.0 A	23.0 A	18.0 A	23.0 A	30.0 A	46.0 A	
For Use With	Motor	Standard 60Hz Pump & 230 V 3-Phase Motor Combination									
	Reference HP Rating*	1.5	2	3	5	7.5	5	7.5	10	15	
Pressure Setting	Factory preset	50 PSI									
	Range	15-95 PSI									
Operating Conditions	"Operating Temperature (at 230V Input)"	"-10°C to 40°C (-15°F to 104°F)"			"-10°C to 50°C (-15°F to 122°F)"		"-10°C to 40°C (-15°F to 104°F)"		"-10°C to 50°C (-15°F to 122°F)"		
	Relative Humidity	Max 95% non-condensing									
	Enclosure Rating	IP66	IP66	IP66	IP55	IP55	IP66	IP55	IP55	IP55	
Physical Characteristics	Controller Size (inches)	7.4 x 10.2 x 9.5			6.8 x 17.8 x 9.5		8.3 x 12.2 x 10.5		6.8 x 17.8 x 9.5		
	Weight	10.6 lbs.	10.6 lbs.	10.6 lbs.	25.4 lbs.	25.4 lbs.	16.1 lbs.	25.4 lbs.	25.4 lbs.	25.4 lbs.	

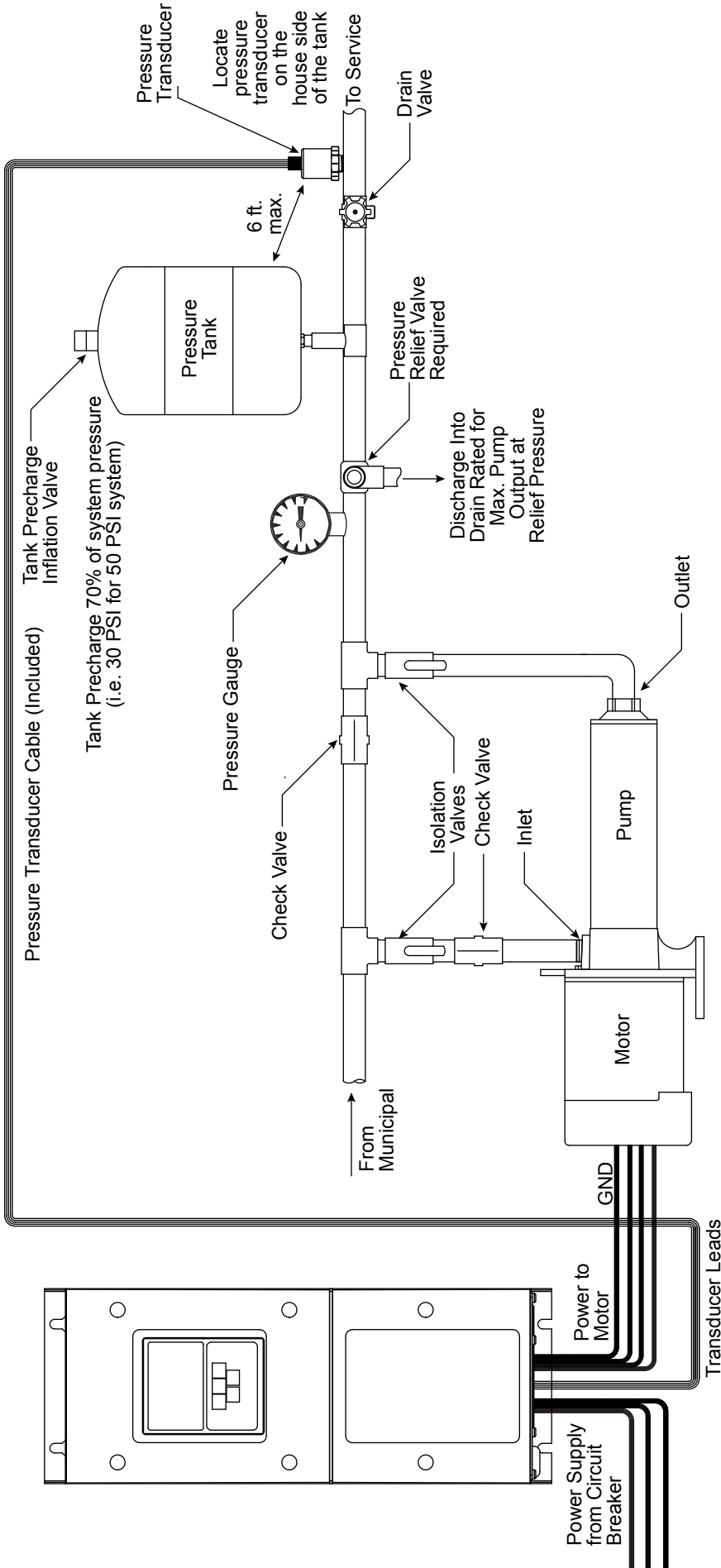

QUICK REFERENCE GUIDE TO CONTROLLER INSTALLATION

IL2207