

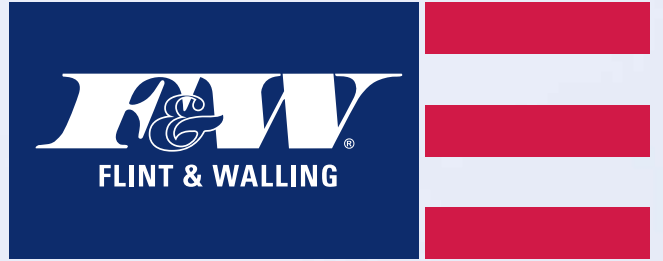

FAMILY OWNED



AMERICAN PROUD™

**LET'S BUILD A LEGACY.
TOGETHER.**





AMERICAN MADE IS MORE THAN A LABEL

Our commitment to our country and our customers.

We are proud that a majority of Flint & Walling branded products are either Made in the USA or Made in the USA using a majority of U.S. Content.

Since 1866, Flint & Walling has remained proud of our U.S. commitment. Buying Flint & Walling means that you're supporting the American workforce.

FAMILY OWNED



AMERICAN PROUD™

Flint & Walling has been Family Owned and American Proud since 1866 and you will see this is part of our logo today. Family Owned stands for hard work, dedication and service. American Proud represents our commitment to supporting domestic suppliers and managing quality through our American work place.

Product Index

4" Submersibles	5
6", 8" and 10" Submersibles	28
Centrifugal Pumps.....	55
Variable Frequency Drives and Systems	
Commander Pro Variable Frequency Drives	109
Z Control Gateway	121
Artesian Drive Controls	123
Artesian Drive Centrifugal Systems	125
Constant Pressure Skid Pumping Stations.....	127
Jet Pumps.....	131
Booster Pumps.....	143
Pond / Fountain Pumps	147
City Water Booster Pumps	151
Poultry House Pumps	153
Sump & Sewage Pumps	159
Multi-stage Effluent Pumps.....	167
Tanks & Accessories	170
F&W Motors and Control Boxes.....	178
Pump Repair Parts	194

TERMS AND CONDITIONS OF SALE

ACCEPTANCE OF ORDERS: All orders are subject to acceptance by Flint & Walling, Inc. in Kendallville, Indiana, and to conditions stated herein. Acceptance of F&W product order constitutes acceptance of the terms and conditions stated herein.

Flint & Walling, Inc. will not be bound by any term or condition on buyer's order which is different from or in addition to the terms and conditions of Flint & Walling.

SHIPPING POLICY: All prices are based upon product sold F.O.B. point of shipment. Flint & Walling will prepay and absorb transportation charges to common carrier points within the continental limitations of the United States, Alaska and Hawaii excluded, in accordance with the freight policy outlined in the Distributor Discount Schedule; and provided Flint & Walling is allowed to select point of origin of shipment, method of transportation and routing of the shipment. Flint & Walling, Inc. reserves the right to add a shipping surcharge due to heavy weight, oversize dimensions, non-pump product mix and/or large order quantities with an order that qualifies for prepaid freight outlined in the Distributor Discount Schedule.

SHIPPING CLAIMS: Customers must review shipment at time of receipt and inspect for damage and missing products. Failure to inspect and document this on the proof of delivery indicates that you have accepted the shipment as complete and damage free.

- Flint & Walling uses blue shrink wrap on all shipments. If product arrives with any other color of shrink wrap, inspect shipment for damage or missing product prior to signing for shipments. In order to receive credit for freight claims, all damage (visible or concealed) or any shipping discrepancies must be submitted to Flint & Walling immediately and must be noted on the proof of delivery. Notifications of damaged freight or shipping discrepancies are made by calling Flint & Walling at 800-345-9422 or by email to sales@flintandwalling.com. Please provide PO #, missing or damaged model #'s, quantities and photos.

Continued on next page.

Flint & Walling will consider all orders as being satisfactorily received and complete by your receiving department if no damage or shipping discrepancies are noted on the proof of delivery and reported to us within 5 days. Please note:

- Flint & Walling is not responsible for any damage or loss of any shipment once it has left the F&W warehouse.
- Return of damaged products requires prior consent of Flint & Walling and are subject to return freight charges and conditions specified above.
- No claims for shortage in weight or quantity will be honored by Flint & Walling unless presented within 5 working days after receipt of goods.
- Part of a shipment can be refused at time of delivery as long as it is noted on the proof of delivery by part number and quantity.

Any claim made outside the specified 5 days from receipt of delivery will not be honored. Payment in full will be required on all orders except those with proper notification.

PRICES: While every effort will be made to provide customers advance notice of price changes, all prices and discounts are subject to change without notice.

Flint & Walling reserves the right to refuse any order due to a price change or price discrepancy; and acceptance of such order by Flint & Walling is subject to customer acceptance of the revised current price.

CANCELLATION: Orders accepted by Flint & Walling in Kendallville, Indiana are not subject to cancellation; but, where cancellation for any cause is mutually agreed to, the purchaser will be billed for reasonable charges based on expenses already incurred and commitments made by Flint & Walling.

TERMS OF PAYMENT: 2% 30 days, Net 45 days. Accounts past due will be subject to a 1 1/2% monthly interest charge. Payments made with a credit card will have a 4% transaction fee applied with no cash discounts.

TERMS AND CONDITIONS OF SALE (continued)

SALES TAX EXEMPTION: F&W is required to have a current sales tax exemption certificate on file for your company. If you have multiple stores or branches that we ship to in other states, please provide a MTC (Multistate Tax Commission) exemption certificate. It is your responsibility to provide the correct form for your state. Failure to provide your sales tax exemption certificate will result in sales tax being charged on your order.

RETURNING PRODUCT: Authorization and shipping instructions must be obtained from Flint & Walling by the purchaser before returning any product. A 15% handling and restocking charge will be charged for new product returned to Flint & Walling for credit. Non-cataloged product is not returnable.

EXPORT COMPLIANCE POLICY: All Flint & Walling products sold outside of the Continental United States are subject to the standards and regulations set forth by the Bureau of Industry and Security. Please consult with the factory on any product that is intended to be exported outside of the United States. See FW1333 for additional information.

LIMITED WARRANTY: This product is warranted, unless otherwise stated, to the user to be free from defects in material and workmanship for a period of one (1) year from the date of purchase. See product literature for specific warranty period.

Subject to the conditions hereinafter set forth, the manufacturer will repair or replace to the original consumer, any portion of the product which proves defective due to defective materials or workmanship. This warranty does not cover replacement parts for failure due to normal wear and tear. To obtain warranty service, contact the dealer from whom the product was purchased. The manufacturer retains the sole right and option to determine whether to repair or replace defective equipment, parts or components. Damage due to conditions beyond the control of the manufacturer is not covered by this warranty.

THIS WARRANTY WILL NOT APPLY:

(a) To defects or malfunctions resulting from failure to properly install, operate or maintain the unit in accordance with printed instructions provided; (b) to failures resulting from abuse, accident or negligence or use of inappropriate chemicals or additives in the water; (c) to normal maintenance services and the parts used in connection with such service; (d) to units which are not installed in accordance with normal applicable local codes, ordinances and good trade practices; and (e) if the unit is used for purposes other than for what it was designed and manufactured.

RETURN OF WARRANTED COMPONENTS:

Any item to be repaired or replaced under this warranty must be returned to the manufacturer at Kendallville, Indiana or such other place as the manufacturer may designate, freight prepaid. THE WARRANTY PROVIDED HEREIN IS IN LIEU OF ALL OTHER EXPRESS WARRANTIES, AND MAY NOT BE EXTENDED OR MODIFIED BY ANYONE. ANY IMPLIED WARRANTIES SHALL BE LIMITED TO THE PERIOD OF THE LIMITED WARRANTY AND THEREAFTER ALL SUCH IMPLIED WARRANTIES ARE DISCLAIMED AND EXCLUDED. THE MANUFACTURER SHALL NOT, UNDER ANY CIRCUMSTANCES, BE LIABLE FOR INCIDENTAL, CONSEQUENTIAL OR SPECIAL DAMAGES, SUCH AS, BUT NOT LIMITED TO DAMAGE TO, OR LOSS OF, OTHER PROPERTY OR EQUIPMENT, LOSS OF PROFITS, INCONVENIENCE, OR OTHER INCIDENTAL OR CONSEQUENTIAL DAMAGES OF ANY TYPE OR NATURE. THE LIABILITY OF THE MANUFACTURER SHALL NOT EXCEED THE PRICE OF THE PRODUCT UPON WHICH SUCH LIABILITY IS BASED.

This warranty gives you specific legal rights, and you may have other rights which vary from state to state. Some states do not allow limitations on duration of implied warranties or exclusion of incidental or consequential damages, so the above limitations may not apply to you.

If you have any questions concerning this or any of our policies and procedures, please do not hesitate to contact your Sales Representative.

Four-Inch Submersible Pumps

FW1674
1022
Supersedes
0122



FOR HOME, FARM AND INDUSTRY

Series "4F"

Low, medium and high capacity submersible pumps for home, farm, industry and many other domestic and commercial applications

- Stainless steel or cast iron suction and discharge housings
- Stainless steel pump shell
- Stainless steel hex drive shaft and coupling
- Stainless steel screen
- Corrosion resistant cable guard
- NEMA standard motor mounting ring
- Field replaceable cartridge assembly, cable guard, motor and motor lead wire assembly
- Stainless steel motors with lightning protection - (F&W available up to 2 HP)



**S SERIES, A SERIES AND G SERIES
SUBMERSIBLES**



'S' Commander®
Series — 304 SS
Suction & Discharge

'A' Captain®
Series —
Cast Iron
Suction &
Discharge

S Series —
4" Deepset
Pumps

5 thru 27 GPM - 'A', 'S' and 'G' Series

35 thru 85 GPM - Hi Cap 'A' and 'S' Series

5, 7, 10, 19 & 27 GPM - 'S' Series DEEPSET

For total head of 1500 ft. or less / 2, 3, 5, & 7-1/2 HP



Material Construction - S Series and A Series



Component Description	Commander® 'S' Series 5, 7, 10, 15, 19 & 27 GPM 1/2 thru 5 HP	Captain® 'A' Series 5, 7, 10, 19 & 27 GPM 1/2 thru 5 HP	Commander® Plus 'S' Series 35, 55 & 85 GPM 1 thru 7-1/2 HP	Captain® Plus 'A' Series 35, 55 & 85 GPM 1 thru 7-1/2 HP
Discharge Head	Stainless Steel, 1-1/4" NPT, safety rope eyelet included	Cast Iron, 1-1/4" NPT, safety rope eyelet included	Stainless Steel, 2" NPT, safety rope eyelets included	Cast Iron, 2" NPT
Check Valve Poppet	Internal removable, with elastomer sealing ring		Check valve not included	
Top Bearing	Closed sintered lead free sleeve bearing		Closed sintered lead free sleeve bearing	Closed sintered lead free sleeve bearing
Pump Shell	Heavy wall stainless steel			
Cable Guard	Stainless steel	Stainless steel or Crush-proof PVC	Stainless steel	Stainless steel or Crush-proof PVC
Staging*	Noryl® impellers and diffusers; stainless steel floating bearing inserts and acetal diffuser plates			
Pump Shaft*	Stainless steel hex shaft with one piece motor-to-shaft coupling			
Motor Bracket	NEMA standard, stainless steel with stainless steel suction screen	NEMA standard, cast iron with stainless steel suction screen	NEMA standard, stainless steel with stainless steel suction screen	NEMA standard, cast Iron with stainless steel suction screen
Motor	All pumps driven by a complete selection stainless steel two wire or three wire motors. (F&W available up to 2 HP).		All pumps driven by a complete selection of stainless steel two wire or three wire motors. (F&W available up to 2 HP). Order motors separately.	
Motor Controls	F&W control boxes required for three-wire single phase motors. Magnetic starters and heaters are required for three phase models. Purchase at your local electrical outlet.			

* Replacement cartridge assembly available for select models. Includes all necessary parts to restore pumps to like-new performance. No special tools required. Noryl® is a registered trademark of General Electric.

Model Number and Date Code



Model Number Code



5 thru 85 GPM

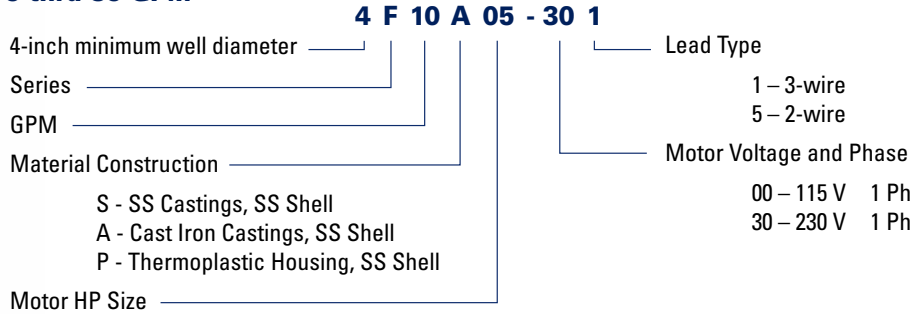

1/2 - 2 HP Single phase pump and motor assembly includes pump/motor unit with motor leads.
 Order control box for 3-wire units separately.
 On 2 - 7-1/2 HP and all 3 phase units, order pump, motor and control box separately. Magnetic starters must be purchased locally. Lead wire assembly included with motor.
 On 35, 55 & 85 GPM units order pump, motor and control box separately. Magnetic starters must be purchased locally. Lead wire assembly included with motor.
 1/2 thru 2 HP, 1 PH pumps feature Flint & Walling motors.

F&W Date Code Explanation

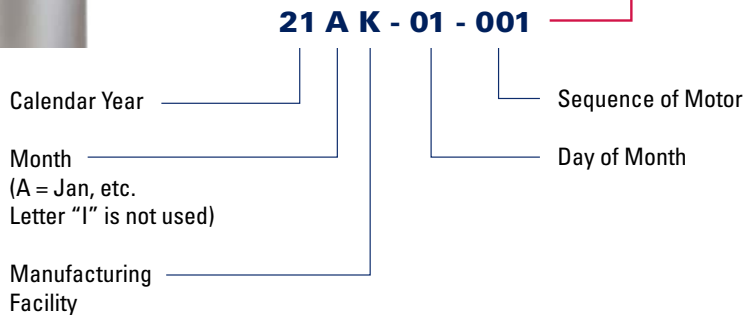

DOE Compliance

PUMP MODEL	Impeller Dia.	P.E.L.c.
4F35	3.072"	0.89
4F55	3.075"	0.93
4F85	3.070"	0.99

- 1-1/4" NPT stainless steel discharge and NEMA faced mounting ring
- Integral removable check valve with elastomer sealing ring
- Stainless steel pump shell, cable guard & suction screen
- Steel intermediate connector
- Thermoplastic impellers and diffusers
- Stainless steel hex drive shaft and coupling
- Selection of stainless steel motors - high thrust motors required on all deep set submersible pump ends

5, 7, 10, 19 & 27 GPM

For total head of 1500 ft. or less

2, 3, 5, & 7-1/2 HP



MODEL SPECIFICATIONS

Pump End Model Number	Motor Required		Number of Stages	Max. Head Ft.	Max. Head PSI	Flow Range GPM*	Overall Pump Length
	HP	Thrust Rating					
4F05S20	2	1500#	42	1108	480	2-9	43.7
4F05S30	3	900#	60	1593	690	2-9	57.8
4F07S30	3	900#	42	1293	560	2-13	43.7
4F10S50	5	1500#	52	1605	695	3-15	56.7
4F19S75	7-1/2	1500#	46	1420	615	6-26	55.4
4F27S75	7-1/2	1500#	42	1282	555	10-34	53.2

For motor lengths, call 1-800-742-5044.

*Refer to motor manufacturer's handbook for proper flow rates to cool motor based on well size.

Component Description	Deepset 'S' Series 5, 7, 10, 19 & 27 GPM 2 through 7-1/2 HP
Discharge Head	NEMA standard, stainless steel, 1-1/4 in NPT, safety rope eyelet included
Check Valve Poppet	Internal removable, with elastomer sealing ring
Top Bearing	Closed sintered lead free sleeve bearing
Intermediate Connector	Rigid Steel
Pump Shell	Heavy wall stainless steel
Cable Guard	Stainless Steel
Staging*	Noryl® impellers and diffusers; stainless steel floating bearing inserts and acetal diffuser plates
Pump Shaft*	304L Stainless steel hex shaft with one piece motor-to-shaft coupling
Motor Bracket	NEMA standard, stainless steel with stainless steel suction screen
Motor	Selection of stainless steel motors - high thrust motors required on all deep set submersible pump ends. Order motors separately.
Motor Controls	Control boxes required for three-wire single phase motors. Magnetic starters and heaters are required for three phase models. Purchase at your local electrical outlet.

* Replacement cartridge assembly available for select models. Includes all necessary parts to restore pumps to like-new performance. No special tools required.

Noryl® is a registered trademark of General Electric.

External line check valve (1-1/4" or larger) required every 100 feet of vertical drop pipe. 900# or 1500# thrust motors required on all deep set submersible pump ends.

4" 7 GPM • 1/2 thru 3 HP 3450 RPM • 60 Cycle

HP Size and Model No.	Stages	Weight		Disch. Press. PSI	DEPTH TO WATER LEVEL IN FEET																								Max. Pressure														
		Motor Type	Ship Wt.		CAPACITIES IN GALLONS PER MINUTE																								Ft.	PSI													
					20	40	60	80	100	120	140	160	180	200	225	250	275	300	325	350	400	450	500	550	600	650	700	800															
1/2 HP 4F07A05 4F07S05 4F07G05	10	1 PH 3 Wire	28	0	12.9	12.2	11.6	10.9	10.3	9.6	8.9	8.1	7.2	6.1	4.7	2.0																			310	134							
		1 PH 2 Wire	28	20	11.3	10.7	10.0	9.3	8.5	7.7	6.8	5.7	4.4	2.8																													
		2 Wire	60	8.1	7.2	6.1	4.9	3.5																																			
3/4 HP 4F07A07 4F07S07 4F07G07	14	1 PH 3 Wire	33	0	12.2	11.8	11.3	10.9	10.3	9.8	9.2	8.6	8.0	7.2	6.3	5.3	3.9	1.8																			430	186					
		1 PH 2 Wire	33	20	11.2	10.7	10.2	9.6	9.1	8.5	7.9	7.2	6.5	5.5	4.2	2.3																											
		2 Wire	60	10.0	9.5	8.9	8.2	7.7	6.9	6.3	5.4	4.4	2.7																														
1 HP 4F07A10 4F07S10 4F07G10	18	1 PH 3 Wire	37	0	12.0	11.9	11.5	11.2	10.8	10.4	10.1	9.7	9.2	8.7	8.1	7.6	7.0	6.3	4.7	2.1																			560	242			
		1 PH 2 Wire	37	20	10.8	11.0	10.7	10.3	9.9	9.6	9.2	8.8	8.3	7.7	7.1	6.5	5.8	4.9	2.5																								
		2 Wire	60	10.6	10.2	9.8	9.5	9.1	8.7	8.2	7.8	7.2	6.6	5.9	5.1	4.1	2.8																										
1-1/2 HP 4F07A15 4F07S15	24	1 PH 3 Wire	51	0	12.7	12.4	12.1	11.7	11.4	10.9	10.6	10.1	9.7	9.2	8.7	8.2	7.7	7.1	6.5	5.8	4.9	2.5																			745	322	
		1 PH 2 Wire	51	20	12.2	12.0	11.7	11.5	11.2	10.9	10.6	10.2	9.9	9.6	9.2	8.8	8.4	8.0	7.1	6.1	4.9	3.3																					
		3 PH 3 Wire	46	40	11.6	11.4	11.1	10.8	10.5	10.3	9.9	9.6	9.2	8.9	8.5	8.1	7.6	7.2	6.2	5.0	3.5																						
2 HP 4F07A20 4F07S20	30	1 PH 3 Wire	61	0	12.7	12.5	12.3	12.1	11.9	11.6	11.3	11.1	10.8	10.5	10.2	9.7	9.1	8.5	7.8	7.1	6.3	5.3	4.4																			945	409
		3 PH 3 Wire	51	20	12.3	12.1	11.9	11.6	11.3	11.1	10.8	10.5	10.2	9.7	9.1	8.5	7.8	7.1	6.3	5.3	4.4																						
		3 Wire	60	11.8	11.6	11.4	11.1	10.9	10.6	10.3	10.1	9.8	9.5	9.2	8.5	7.9	7.2	6.4	5.5	4.4																							

HP Size and Model No.	Stages	Weight		Disch. Press. PSI	DEESET - DEPTH TO WATER LEVEL IN FEET																								Max. Pressure																		
		Motor Type	Ship Wt.		CAPACITIES IN GALLONS PER MINUTE																								Ft.	PSI																	
					50	100	150	200	250	300	350	400	450	500	550	600	650	700	750	800	900	1000	1100	1200	1300	1400	1500	1600																			
3 HP 4F07S30	42	1 PH 3 Wire	30	0	12.9	12.9	12.5	12.1	11.8	11.4	11.0	10.6	10.2	9.8	9.5	9.0	8.6	8.2	7.7	7.2	6.7	6.2	5.7	5.2	4.7	4.2	3.8																			1293	560
		3 PH 3 Wire	30	20	12.8	12.5	12.1	11.7	11.3	11.0	10.6	10.2	9.8	9.4	9.0	8.6	8.1	7.7	7.2	6.1	4.7	2.5																									
		3 Wire	60	12.9	12.5	12.1	11.7	11.3	11.0	10.6	10.2	9.8	9.5	9.0	8.6	8.2	7.7	7.2	6.7	6.2	5.7	5.2	4.7	4.2	3.8																						

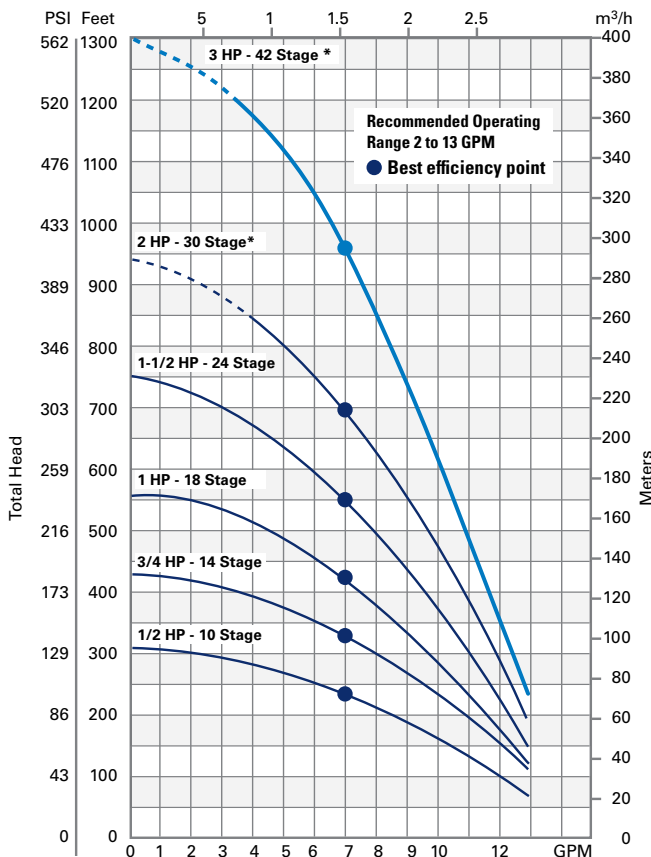

NOTE: Pipe friction loss in drop pipe is not included in chart above.
1/2 thru 2 HP, 1 PH pumps feature Flint & Walling motors.

Stainless Steel
1-1/4" NPT



← 3.72" →

Cast Iron
1-1/4" NPT



← 3.72" →

* Pumps marked with asterisks not to be operated at GPM flows indicated by dotted lines.

4" 10 GPM • 1/2 thru 5 HP 3450 RPM • 60 Cycle



HP Size and Model No.	Stage	Weight		Discharge Pressure PSI	DEPTH TO WATER LEVEL IN FEET																								Max. Press.		
		Motor Type	Ship Wt.		20	40	60	80	100	120	140	160	180	200	225	250	275	300	350	400	450	500	550	600	650	700	800	900	Ft.	PSI	
					CAPACITIES IN GALLONS PER MINUTE																										
1/2 HP 4F10A05 4F10S05 4F10G05	8	1 PH 3 Wire	27	0																							250	108			
				20	14.6	14.1	14.7	14.2	13.4	12.6	11.7	10.8	9.7	8.3	6.3	2.1															
		1 PH 2 Wire	27	40	12.8	12.0	11.0	10.0	8.7	6.9	4.8																				
				60	10.9	9.9	8.6	6.7	4.5																						
				80	7.8	4.9	3.6																								
3/4 HP 4F10A07 4F10S07 4F10G07	12	1 PH 3 Wire	32	0																						375	162				
				20		14.9	14.5	15.0	14.6	14.1	13.6	13.1	12.5	12.0	11.3	10.4	9.7	8.5	5.7												
		1 PH 2 Wire	32	40	14.3	13.8	13.3	12.8	12.4	11.4	11.0	10.5	9.6	8.9	7.4	6.1	3.5														
				60	13.2	12.6	12.1	11.5	10.9	10.3	9.6	8.7	7.7	6.6	3.8																
				80	11.9	11.4	10.6	10.0	9.3	8.4	7.4	6.2	3.8																		
1 HP 4F10A10 4F10S10 4F10G10	15	1 PH 3 Wire	36	0																						470	203				
				20		14.9	14.5	15.0	14.7	14.3	13.8	13.4	13.0	12.6	12.1	11.6	10.9	10.2	9.6	7.6	4.6										
		1 PH 2 Wire	36	40	14.9	14.5	14.1	13.7	13.3	12.9	12.4	11.9	11.4	10.9	10.3	9.5	8.6	7.9	4.5												
				60	13.9	13.5	12.7	12.7	12.3	11.8	11.2	10.9	10.3	9.7	8.9	7.8	6.6	5.0													
				80	13.1	12.6	12.1	11.7	11.2	10.7	10.1	9.7	9.0	8.2																	
1-1/2 HP 4F10A15 4F10S15 4F10G15	20	1 PH 3 Wire	47	0																						630	272				
				20		15.0	14.8	14.5	14.2	13.9	13.6	13.4	13.0	12.7	12.4	11.9	11.5	11.0	10.0	8.6	7.1	4.4									
		1 PH 2 Wire	47	40		15.0	14.8	14.5	14.2	13.9	13.6	13.4	13.0	12.7	12.4	11.9	11.5	11.0	10.0	8.6	7.1	4.4									
				60	14.7	14.5	14.1	13.9	13.6	13.2	12.9	12.7	12.3	12.0	11.5	11.1	10.6	10.1	8.8	7.3	4.8										
				80	14.1	13.8	13.5	13.2	12.9	12.6	12.2	11.8	11.4	11.0	10.5	10.1	9.6	9.0	7.4	4.9											
2 HP 4F10A20 4F10S20	26	1 PH 3 Wire	62	0																						815	352				
				20		15.0	14.8	14.6	14.4	14.4	14.2	14.0	13.8	13.4	13.2	12.9	12.6	12.3	11.9	11.3	10.5	9.6									
		3 PH 3 Wire	53	40		15.0	14.8	14.6	14.4	14.4	14.2	14.0	13.8	13.4	13.2	12.9	12.6	12.3	11.9	11.3	10.5	9.6									
				60	14.7	14.5	14.3	14.1	13.8	13.6	13.4	13.2	13.0	12.6	12.3	12.0	11.7	11.4	10.5	9.7											
				80	14.7	14.5	14.3	14.1	13.8	13.6	13.4	13.2	13.0	12.6	12.3	12.0	11.7	11.4	10.5	9.7											
3 HP 4F10A30 4F10S30	34	1 PH 3 Wire	79	0																						1070	462				
				20		15.4	15.2	15.0	14.8	14.6	14.4	14.3	14.0	13.9	13.7	13.6	13.4	13.1	12.8	12.2	11.9	11.4	10.8	10.2	9.5			8.6	7.5		
		3 PH 3 Wire	70	40		15.4	15.2	15.0	14.8	14.6	14.4	14.3	14.0	13.9	13.7	13.6	13.4	13.1	12.8	12.2	11.9	11.4	10.8	10.2	9.5			8.6	7.5		
				60	15.3	15.0	14.8	14.6	14.4	14.2	14.1	14.0	13.9	13.7	13.6	13.4	13.1	12.8	12.2	11.9	11.4	10.8	10.2	9.5	8.6			7.5			
				80	15.3	15.0	14.8	14.6	14.4	14.2	14.1	14.0	13.9	13.7	13.6	13.4	13.1	12.8	12.2	11.9	11.4	10.8	10.2	9.5	8.6	7.5					

HP Size and Model No.	Stage	Weight		Discharge Pressure PSI	DEEPSET - DEPTH TO WATER LEVEL IN FEET																								Max. Press.		
		Motor Type	Ship Wt.		50	100	150	200	250	300	350	400	450	500	550	600	650	700	750	800	900	1000	1100	1200	1300	1400	1500	1600	Ft.	PSI	
					CAPACITIES IN GALLONS PER MINUTE																										
5 HP 4F10S50	52	1 PH 3 Wire	36	0																						1605	695				
				20		15.2	14.9	14.6	14.3	14.1	13.8	13.5	13.2	12.9	12.6	12.3	12.0	11.7	11.0	10.3	9.5	8.6	7.5	6.1	3.4						
		3 PH 3 Wire	36	40		15.2	14.9	14.6	14.4	14.1	13.8	13.5	13.2	12.9	12.6	12.3	12.0	11.7	11.4	10.7	9.9	9.1	8.1	6.9	5.1						
				60		14.9	14.7	14.4	14.1	13.8	13.5	13.2	13.0	12.7	12.4	12.0	11.7	11.4	11.1	10.3	9.5	8.7	7.6	6.2	3.7						
				80	15.0	14.7	14.4	14.1	13.8	13.6	13.3	13.0	12.7	12.4	12.1	11.7	11.4	11.1	10.7	10.0	9.2	8.2	7.0	5.3							

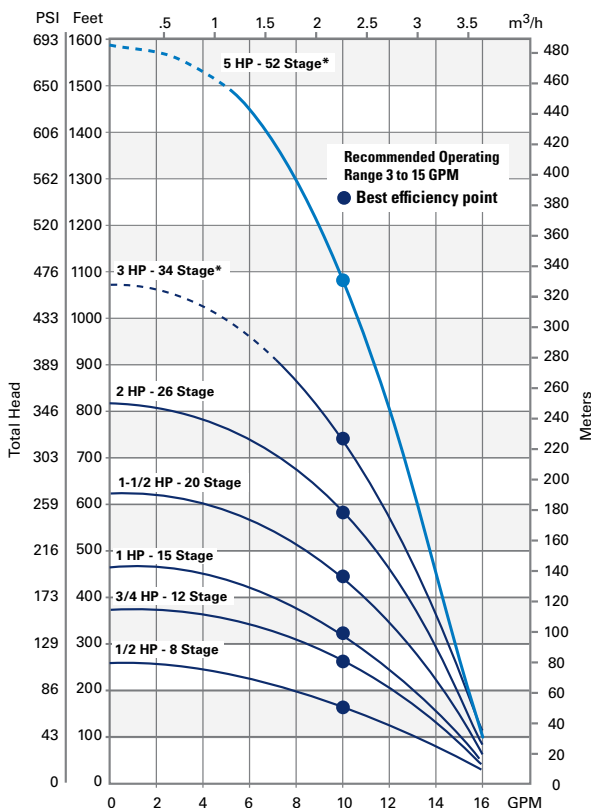

NOTE: Pipe friction loss in drop pipe is not included in chart above.
1/2 thru 2 HP, 1 PH pumps feature Flint & Walling motors.



* Pumps marked with asterisks not to be operated at GPM flows indicated by dotted lines.

4" 15 GPM • 1/2 thru 2 HP 3450 RPM • 60 Cycle

HP Size and Model No.	Stage	Weight		Discharge Pressure PSI	DEPTH TO WATER LEVEL IN FEET																			Max. Press.						
		Motor Type	Ship Wt.		20	40	60	80	100	120	140	160	180	200	225	250	275	300	350	400	450	500	550	600	650	700	800	900	Ft.	PSI
					CAPACITIES IN GALLONS PER MINUTE																									
1/2 HP 4F15S05	5	1 PH	28	0																							159	69		
		3 Wire	28	19.8	22.0	20.5	18.5	16.2	13.7	10.2																				
		2 Wire	28	14.6	11.6	7.0	8.8																							
3/4 HP 4F15S07	7	1 PH	33	0																							214	93		
		3 Wire	33	21.5	20.5	21.9	20.9	19.5	18.0	16.4	14.6	11.8	7.8																	
		2 Wire	33	14.6	11.8	8.1	9.5	9.5																						
1 HP 4F15S10	9	1 PH	36	0																							279	121		
		3 Wire	36	21.4	20.4	21.6	20.7	19.6	18.2	16.6	14.9	12.7	9.8	9.2																
		2 Wire	36	15.0	12.6	10.0	6.3	7.7	7.7																					
1-1/2 HP 4F15S15	12	1 PH	33	0																							367	159		
		3 Wire	33	21.6	21.0	21.8	21.2	20.5	19.7	18.8	18.0	17.1	16.1	14.7	12.9	10.5	7.3	6.4												
		2 Wire	33	18.1	17.2	16.2	15.1	13.9	12.2	10.1	7.5																			
2 HP 4F15S20	16	1 PH	36	0																							489	212		
		3 Wire	36	21.7	21.2	21.8	21.2	20.7	20.2	19.5	18.9	18.1	17.4	16.5	15.6	14.5	13.1	9.2	8.5											
		2 Wire	36	17.6	17.0	16.2	15.5	14.6	13.6	12.5	11.4	10.3	9.2	8.1	7.0	5.9	4.8	3.7	2.6	1.5										

NOTE: Pipe friction loss in drop pipe is not included in chart above. 1/2 thru 2 HP, 1 PH pumps feature Flint & Walling motors.

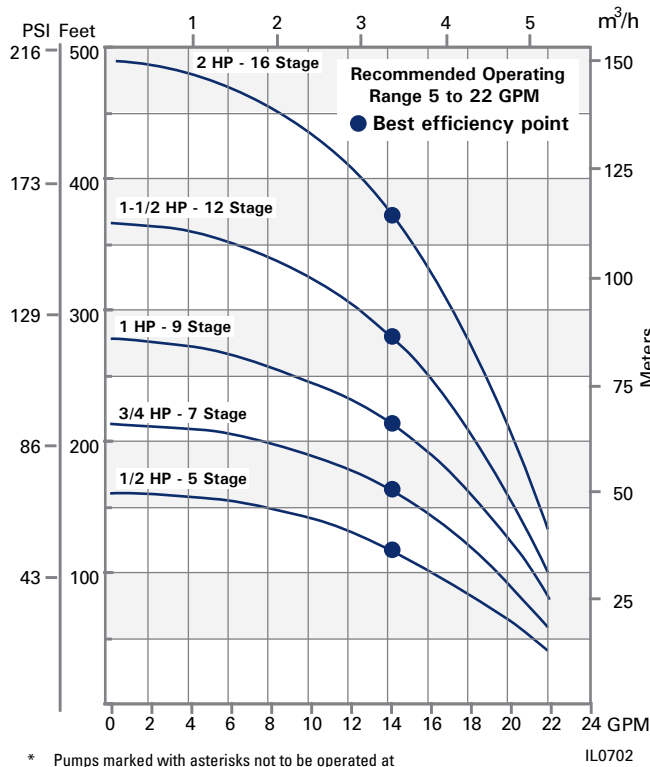

4" 19 GPM • 1/2 thru 7-1/2 HP 3450 RPM • 60 Cycle



HP Size and Model No.	Stg.	Weight		Disch. Press. PSI	DEPTH TO WATER LEVEL IN FEET																	Max. Pressure								
		Motor Type	Ship Wt.		20	40	60	80	100	120	140	160	180	200	225	250	275	300	325	350	400	450	500	550	600	650	700	800	Ft.	PSI
					CAPACITIES IN GALLONS PER MINUTE																									
1/2 HP 4F19A05 4F19S05	5	1 PH	28	0	24.6	22.7	20.5	17.9	15.0	10.4																		155	67	
		3 Wire	28	22.0	19.8	17.1	14.0	5.9																						
		1 PH 2 Wire	28	16.0	12.2	3.5																								
3/4 HP 4F19A07 4F19S07	7	1 PH	33	0	24.4	22.9	21.4	19.5	17.5	15.3	12.4	8.6	13.3	9.6															215	93
		3 Wire	33	20	24.4	20.6	18.7	16.6	14.3	11.0	5.5																			
		1 PH 2 Wire	33	40	20.6	16.2	13.6	10.2																						
1 HP 4F19A10 4F19S10 4F19G10	9	1 PH	36	0	25.5	24.4	23.2	22.1	20.7	19.4	17.8	16.2	13.7	10.7	5.0												283	122		
		3 Wire	36	20	25.2	24.0	22.9	21.7	20.4	19.0	17.4	15.6	13.7	11.4	6.2															
		1 PH 2 Wire	36	40	22.5	21.2	19.8	18.4	16.8	15.2	12.8	10.4	5.6																	
1-1/2 HP 4F19A15 4F19S15 4F19G15	12	1 PH	43	0	25.5	24.6	23.8	22.9	22.0	21.1	20.1	18.9	17.5	15.1	14.3	11.8	8.7							375	163					
		3 Wire	43	20	25.2	24.4	23.5	22.7	21.7	20.7	19.9	18.9	17.7	16.3	14.3	12.2	9.5	3.6												
		1 PH 2 Wire	43	40	24.2	23.3	22.4	21.4	20.5	19.5	18.5	17.4	16.3	14.9	12.7	9.7														
2 HP 4F19A20 4F19S20	16	1 PH	59	0	25.7	25.1	24.5	23.8	23.2	22.5	21.8	21.0	20.2	19.2	18.2	17.0	15.9	14.4	10.8	5.0	3.3					500	217			
		3 Wire	49	20	25.3	24.6	24.1	23.5	22.8	22.2	21.5	20.8	20.1	19.3	18.3	17.2	15.9	14.6	12.9	11.0	5.3									
		3 PH 3 Wire	49	40	23.9	23.3	22.7	22.0	21.3	20.6	19.8	19.1	18.3	17.4	16.3	14.8	13.2	11.3	9.2	6.2										
3 HP 4F19A30 4F19S30	22	1 PH	75	0	25.7	25.2	24.8	24.3	23.8	23.3	22.8	22.2	21.7	21.0	20.3	19.8	19.0	18.2	16.6	14.7	12.2	8.3					685	298		
		3 Wire	75	20	25.3	24.8	24.3	23.9	23.5	23.0	22.5	22.1	21.5	21.0	20.5	19.8	19.2	18.3	17.6	16.8	14.8	12.5	9.3							
		3 PH 3 Wire	75	40	24.2	23.9	23.3	22.8	22.3	21.9	21.4	20.9	20.3	19.8	19.2	18.4	17.7	16.9	16.0	14.9	12.7	9.5	3.3							
5 HP 4F19A50 4F19S50	32	1 PH	117	0	25.9	25.6	25.3	25.0	24.7	24.4	24.1	23.7	23.2	22.8	22.4	21.9	21.2	20.3	19.3	18.3	17.2	15.9	14.5	12.8				1000	435	
		3 Wire	80	20	26.0	25.8	25.5	25.2	24.9	24.6	24.3	23.9	23.4	22.9	22.4	21.9	21.2	20.3	19.3	18.3	17.2	15.8	14.5							
		3 PH 3 Wire	80	40	25.7	25.3	25.1	24.8	24.5	24.2	23.8	23.5	23.2	22.8	22.5	22.2	21.7	21.3	20.8	20.4	19.4	18.4	17.3	16.2	14.7					

HP Size and Model No.	Stg.	Weight		Disch. Press. PSI	DEEPCSET - DEPTH TO WATER LEVEL IN FEET																	Max. Pressure								
		Motor Type	Ship Wt.		50	100	150	200	250	300	350	400	450	500	550	600	650	700	750	800	900	1000	1100	1200	1300	1400	1500	1600	Ft.	PSI
					CAPACITIES IN GALLONS PER MINUTE																									
7-1/2 HP 4F19S75	46	3 PH	35	0	25.9	25.3	24.7	24.1	23.5	22.9	22.3	21.7	21.1	20.4	19.7	19.0	18.3	17.6	16.8	15.9	14.9	13.8	12.8	11.6	10.2				1420	615
		3 Wire	35	20	25.4	24.8	24.2	23.5	22.9	22.3	21.7	21.1	20.4	19.7	19.0	18.3	17.6	16.8	15.9	14.9	13.8	12.8	11.6	10.2						
			35	40	26.1	25.5	24.9	24.2	23.6	23.0	22.4	21.7	21.1	20.5	19.8	19.1	18.4	17.7	16.9	16.0	15.2	14.1	13.0	11.8	10.5					

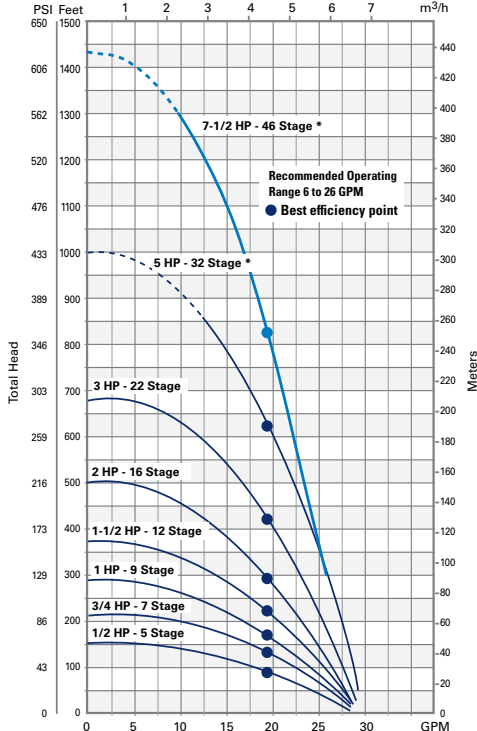

NOTE: Pipe friction loss in drop pipe is not included in chart above.
1/2 thru 2 HP, 1 PH pumps feature Flint & Walling motors.



* Pumps marked with asterisks not to be operated at GPM flows indicated by the dotted line.

4" 27 GPM • 3/4 thru 7-1/2 HP 3450 RPM • 60 Cycle

HP Size And Model No.	Stages	WEIGHT		Disch. Press. PSI	DEPTH TO WATER LEVEL IN FEET																												Max. Pressure							
		Motor Type	Shp. Weight		CAPACITIES IN GALLONS PER MINUTE																												Ft.	PSI						
					20	40	60	80	100	120	140	160	180	200	220	240	260	280	300	350	400	450	500	550	600	650	700	750	800											
3/4 HP 4F27A07 4F27S07	6	1 PH	33	0	32	29	32	30	27	24	21	16	5																									180	78	
		3 Wire		20	25	26	26	23	20	15																														
1 HP 4F27A10 4F27S10	7	1 PH	35	0	33	31	34	32	30	27	24	22	18	13																									215	93
		3 Wire		20	28	29	29	26	24	20	17	10																												
1-1/2 HP 4F27A15 4F27S15	10	1 PH	43	0			34	33	31	29	28	26	24	22	20	17	14	6												305	132									
		3 Wire		20			30	29	27	25	24	22	19	16	11																									
2 HP 4F27A20 4F27S20	12	1 PH	44	0			34	33	32	31	30	28	27	26	24	22	20	18	9												360	156								
		3 Wire		20			30	29	27	25	24	22	19	16	12	5																								
3 HP* 4F27A30 4F27S30	17	1 PH	73	0				34	33	33	32	31	30	29	28	27	26	25	21	17	10	9												515	223					
		3 Wire		20			30	30	30	29	28	27	25	24	23	21	17	11																						
5 HP* 4F27A50 4F27S50	29	1 PH	116	0					34	34	34	34	33	33	32	31	30	29	27	26	24	22	20	18	15	12												880	380	
		3 Wire		20				30	30	30	29	28	27	26	24	23	21	17	12																					

HP Size And Model No.	Stages	WEIGHT		Disch. Press. PSI	DEEPSET - DEPTH TO WATER LEVEL IN FEET																												Max. Pressure	
		Motor Type	Shp. Weight		CAPACITIES IN GALLONS PER MINUTE																												Ft.	PSI
					50	100	150	200	250	300	350	400	450	500	550	600	650	700	750	800	900	1000	1100	1200	1300	1400	1500	1600	1700					
7-1/2 HP 4F27S75	42	3 PH 3 Wire	34	0																													1282	555
				20																														
				40																														
				60																														
				80	34.1	33.2	32.4	31.6	30.8	29.9	29.1	28.2	27.3	26.4	25.4	24.4	23.3	22.2	19.5	16.0														

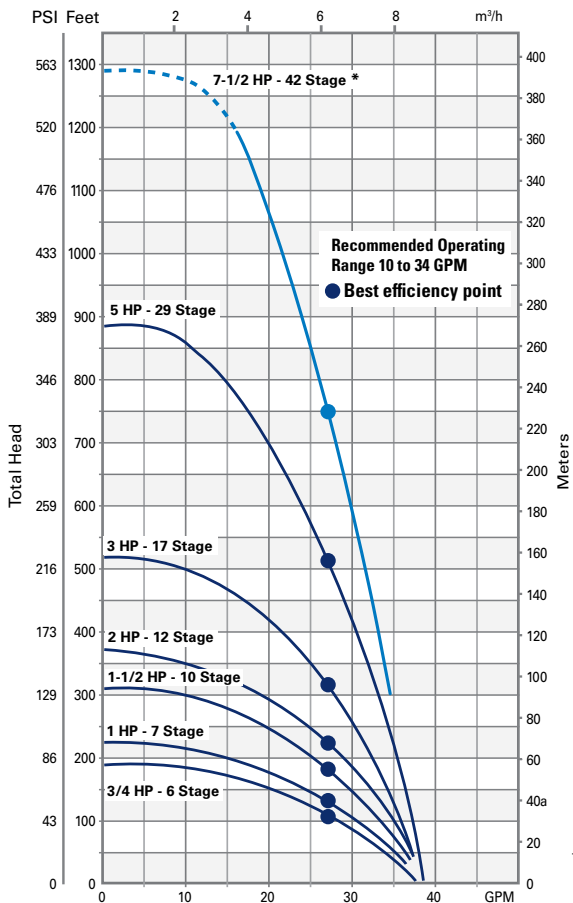

NOTE: Pipe friction loss in drop pipe is not included in chart above. 1/2 thru 2 HP, 1 PH pumps feature Flint & Walling motors.
*For 3 HP and above, refer to motor manufacturer's handbook for proper flow rates to cool motor.



* Pumps marked with asterisks not to be operated at GPM flows indicated by the dotted line.

4" 35 GPM • 1 thru 7-1/2 HP 3450 RPM • 60 Cycle



HP Size And Model No.	Stages	Phase	WEIGHT		Disch. Press. PSI	DEPTH TO WATER LEVEL IN FEET																				Max. Pressure			
			Pump End	Motor End		20	40	60	80	100	120	140	160	180	200	220	240	260	300	350	400	450	500	550	600	650	700	Ft.	PSI
			CAPACITIES IN GALLONS PER MINUTE																										
1 HP 4F35A10 4F35S10	4	1	11	23	0 20 40 60	42 30	47 37 22	43 32	38 25	33	27																	140	67
1-1/2 HP 4F35A15 4F35S15	5	1 3	12 12	28 25	0 20 40 60	46 26	43 38 15	39 33 28	43 35	40 30	36 23	31	25	10													180	78	
2 HP 4F35A20 4F35S20	7	1 3	14 14	30 28	0 20 40 60		47 41 34	50 45 38 31	48 42 35 26	45 39 32 19	43 36 28	40 33 22	37 29	34 24	30	26	19										245	106	
3 HP* 4F35A30 4F35S30	10	1 3	17 17	52 43	0 20 40 60			48 45 40	47 45 38	45 43 36	43 41 34	41 39 31	39 37 28	42 37 25	40 35 20	38 33 22	36 30 17	33 27 17	28 18	17								355	154
5 HP* 4F35A50 4F35S50	16	1 3	23 23	69 53	0 20 40 60				49 47	50 48 46	49 47 44	48 46 43	48 46 42	47 45 41	46 44 40	45 43 38	44 41 37	42 39 32	39 36 28	35 32 22	31 27 21	26 21	20				560	245	
7-1/2 HP* 4F35A75 4F35S75	23	3	31	69	0 20 40 60				49 47	50 48 46	49 47 44	48 46 43	48 46 42	47 45 41	46 44 40	45 43 38	44 41 37	42 39 32	39 36 28	36 33 22	31 28 24	28 24 20				810	350		

NOTE: Pipe friction loss in drop pipe is not included in chart above.
 *For 3 HP and above, refer to motor manufacturer's handbook for proper flow rates to cool motor.
 1/2 thru 2 HP, 1 PH pumps feature Flint & Walling motors.

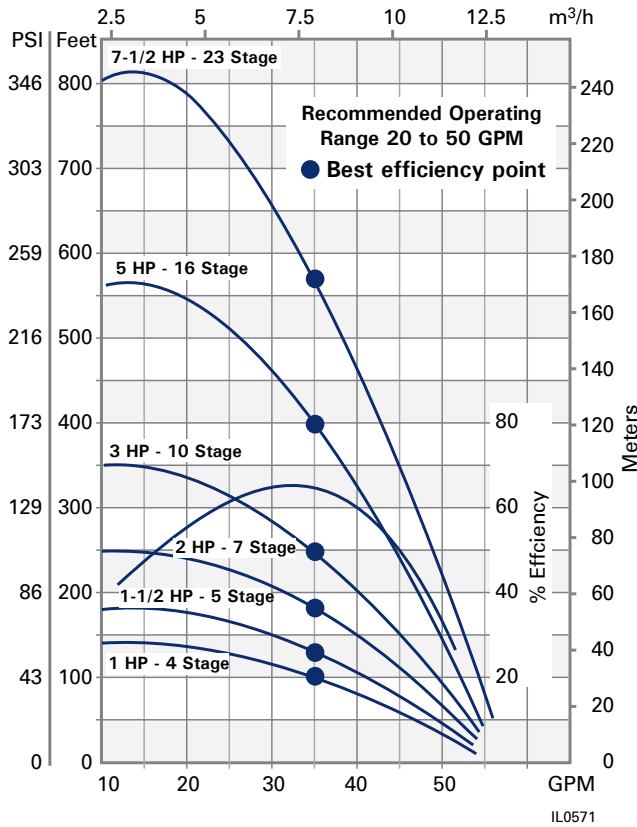

4" 55 GPM • 1-1/2 thru 7-1/2 HP 3450 RPM • 60 Cycle

HP Size and Model No.	Stages	Phase	Weight		Discharge Pressure PSI	DEPTH TO WATER LEVEL IN FEET																			Maximum Pressure	
			Pump End	Motor End		20	40	60	80	100	120	140	160	180	200	220	240	260	300	350	400	450	500	550	Ft.	PSI
			CAPACITIES IN GALLONS PER MINUTE																							
1-1/2 HP 4F55A15 4F55S15	4	1 3	12 12	28 25	0 20 40 60	70 42	60 23	71 47	62 33	50	36													135	58	
2 HP 4F55A20 4F55S20	5	1 3	14 14	30 28	0 20 40 60	74 56 30	68 45	75 59 34	69 50	61 38	51 15	42	29											165	71	
3 HP* 4F55A30 4F55S30	7	1 3	16 16	52 43	0 20 40 60		75 63 48	70 57 40	75 65 32	71 59 43	66 53 34	61 46 15	55 38	47 28	39	31								235	101	
5 HP* 4F55A50 4F55S50	11	1 3	19 19	69 53	0 20 40 60			72 65	69 62	73 66 58	70 63 53	74 67 49	71 64 44	68 60 39	64 56 33	61 52 25	57 47 35	53 42 30	44 31	30				365	158	
7-1/2 HP* 4F55A75 4F55S75	18	3	28	69	0 20 40 60						75 71	73 70	75 72	74 68	72 68	74 66	73 63	71 59	66 51	62 43	56 35	49 25	41 24	33 20	600	259

NOTE: Pipe friction loss in drop pipe is not included in chart above.
 *For 3 HP and above, refer to motor manufacturer's handbook for proper flow rates to cool motor.
 1/2 thru 2 HP, 1 PH pumps feature Flint & Walling motors.

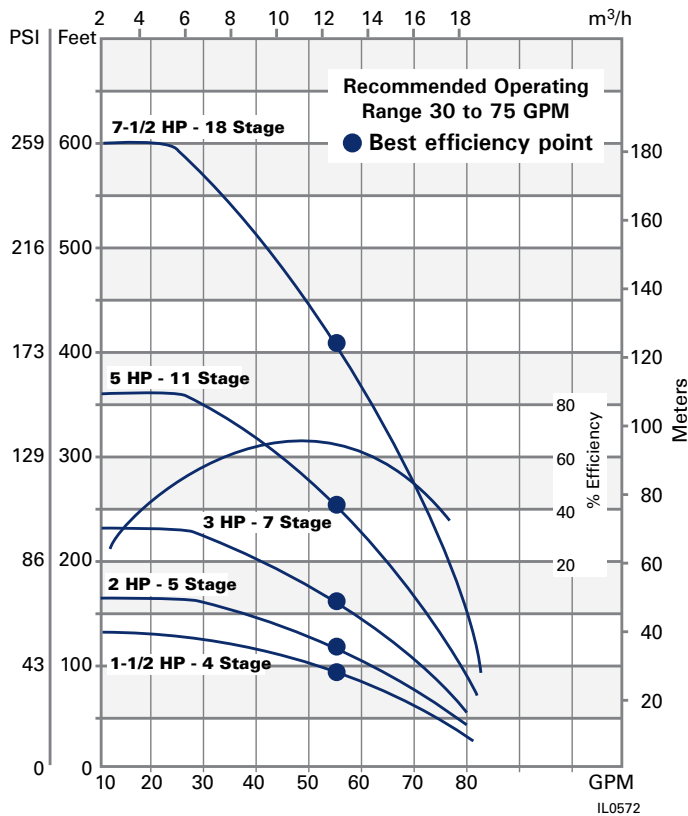

4" 85 GPM • 2 thru 7-1/2 HP 3450 RPM • 60 Cycle



HP Size and Model No.	Stages	Phase	Weight		Discharge Pressure PSI	DEPTH TO WATER LEVEL IN FEET																			Max. Pressure			
			Pump End	Motor End		20	40	60	80	100	120	140	160	180	200	220	240	260	280	300	320	340	360	380	400	Ft.	PSI	
						CAPACITIES IN GALLONS PER MINUTE																						
2 HP 4F85A20 4F85S20	4	1 3	13 13	30 28	0 20 40 60	80 35	105 60	85 40	64	45														120	52			
3 HP* 4F85A30 4F85S30	6	1 3	15 15	52 43	0 20 40 60	101 70 40	88 56 25	103 75 43	91 61 30	77 48	63 34	51 38												185	80			
5 HP* 4F85A50 4F85S50	10	1 3	20 20	69 53	0 20 40 60	100 81	108 91 73	102 94 65	110 86 57	103 78 49	95 70 41	87 70 33	79 62 20	71 54 36	63 46 25	55 38	48 30	40	32						300	130		
7-1/2 HP* 4F85A75 4F85S75	15	3	27	69	0 20 40 60	103 81	109 73	104 92	110 99 87	106 94 81	101 88 76	95 83 70	106 90 65	102 85 59	97 72 54	91 74 49	85 61 43	80 66 43	74 63 38	69 57 32	64 52 25	59 47 27	53 41 27	48 36	43 30	38	450	195

NOTE: Pipe friction loss in drop pipe is not included in chart above.
*For 3 HP and above, refer to motor manufacturer's handbook for proper flow rates to cool motor.
1/2 thru 2 HP, 1 PH pumps feature Flint & Walling motors.

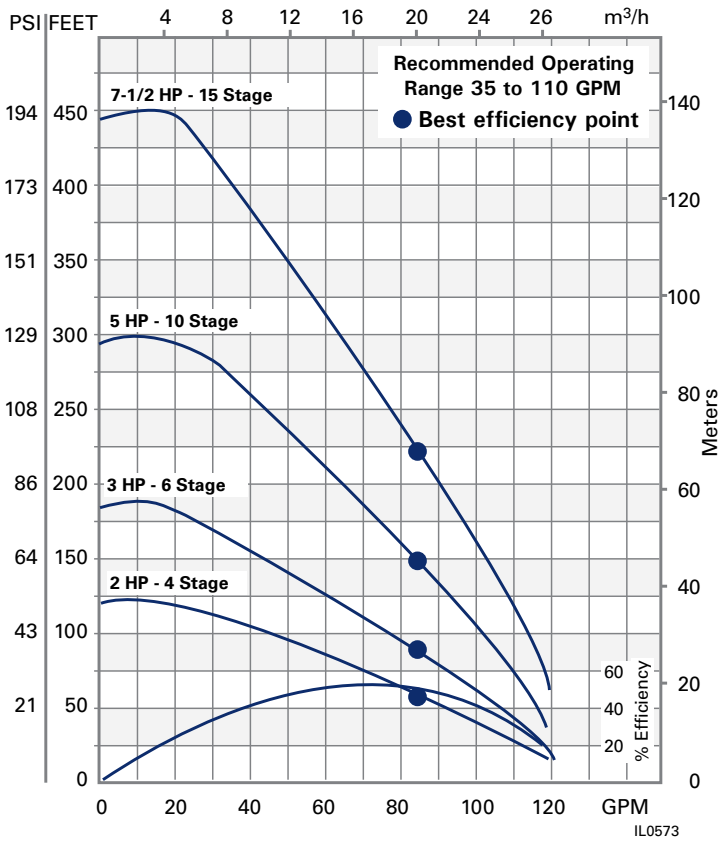

5 thru 85 GPM • 1/2 thru 7-1/2 HP Motor, VFD, and Control Box Chart

HP	Voltage & Phase	Motor Type	F&W Motor Thrust Rating	F&W Motor Order No.	F&W Control Box Order Number	F&W VFD Order Number	Motor Order Number	Control Box Order Number
1/2	115V / 1PH	3-Wire	700#	137426	022875	--	M137426	127185
	230V / 1PH	3-Wire	700#	137428	022876	--	M137428	127189
	115V / 1PH	2-Wire	700#	137412	--	--	M137412	--
	230V / 1PH	2-Wire	700#	137414	--	--	M137414	--
3/4	230V / 1PH	3-Wire	700#	137430	022877	--	M137430	127197
	230V / 1PH	2-Wire	700#	137416	--	--	M137416	--
1	230V / 1PH	3-Wire	700#	137432	022878	--	M137432	126319
	230V / 1PH	2-Wire	700#	137418	--	--	M137418	--
1-1/2	230V / 1PH	3-Wire	700#	137434	022879	--	M137434	133589
	230V / 1PH	2-Wire	700#	137420	--	--	M137420	--
	200V / 3PH	3-Wire	N/A	N/A	--	N/A	M137457	--
	230V / 3PH	3-Wire	N/A	N/A	--	TVS15	M137458	--
	460V / 3PH	3-Wire	N/A	N/A	--	N/A	M137460	--
2	230V / 1PH	3-Wire	700#	137435	025242	--	M137435	137224+ 126321++
	200V / 3PH	3-Wire	N/A	N/A	--	N/A	M137461	--
	230V / 3PH	3-Wire	N/A	N/A	--	TVS20	M137462	--
	460V / 3PH	3-Wire	N/A	N/A	--	N/A	M137464	--
3	230V / 1PH	3-Wire	N/A	N/A	025243	--	M139422	136800+ 126322++
	200V / 3PH	3-Wire	N/A	N/A	--	N/A	M139423	--
	230V / 3PH	3-Wire	N/A	N/A	--	TVS30	M139424	--
	460V / 3PH	3-Wire	N/A	N/A	--	N/A	M139425	--
5	230V / 1PH	3-Wire	N/A	N/A	025244	--	M137456	135269+ 137225++
	200V / 3PH	3-Wire	N/A	N/A	--	N/A	M137469	--
	230V / 3PH	3-Wire	N/A	N/A	--	N/A	M137470	--
	460V / 3PH	3-Wire	N/A	N/A	--	N/A	M137472	--
7-1/2	200V / 3PH	3-Wire	N/A	N/A	--	N/A	M137473	--
	230V / 3PH	3-Wire	N/A	N/A	--	N/A	M137474	--
	460V / 3PH	3-Wire	N/A	N/A	--	N/A	M137476	--

N/A Not available

+ Deluxe control box – includes magnetic contactor. Recommended for water systems which utilize pressure switch.

++ Standard control box.

"G" Series Submersible Pumps



G SERIES SUBMERSIBLE PUMPS

FW1675
0521
Supersedes
1020

5, 7, 10, 19 AND 27 GPM PUMPS

Features

- Positive sealing removable check valve
- Cast iron discharge and NEMA-faced mounting ring
- Non-fusing and corrosion-resistant impellers and diffusers molded of Noryl® resin
- Stainless steel suction screen
- Powder-coated carbon steel pump shell
- Stainless steel hex drive shaft
- Flint & Walling NEMA standard 2- or 3-wire lightning protected motor

Noryl® is a registered Trademark of General Electric Company



G Series Submersibles



2 and 3 wire

1/2 thru 1-1/2 HP

For 4" Diameter Wells or Larger



4" 5 GPM • 7 GPM • 3450 RPM • 60 Cycle

Model No.	Stages	HP	Wire	Volts	Discharge Pressure PSI	DEPTH TO WATER LEVEL IN FEET																				Maximum Pressure										
						20	40	60	80	100	120	140	160	180	200	225	250	275	300	325	350	400	450	500	550	Ft.	PSI									
						CAPACITIES IN GALLONS PER MINUTE																														
5 GPM 4F05G05001 4F05G05301 4F05G05005 4F05G05305	15	1/2	3	115	0																					390	168									
					20																															
					40	8.8	8.4	8.1	7.7	7.3	6.9	6.5	6.0	5.5	4.8	4.1	3.3	2.3																		
					115	8.3	7.9	7.5	7.1	6.7	6.3	5.9	5.4	4.9	4.2	3.5	2.4																			
7 GPM 4F07G05001 4F07G05301 4F07G05005 4F07G05305	10	1/2	3	115	0																					310	134									
					20	12.9	12.2	11.6	10.9	10.3	9.6	8.9	8.1	7.2	6.1	4.7	2.0																			
					40	11.3	10.7	10.0	9.3	8.5	7.7	6.8	5.7	4.4	2.8																					
					115	9.8	9.1	8.3	7.5	6.5	5.3	4.0	2.3																							
7 GPM 4F07G07301 4F07G07305	14	3/4	3	230	0																					430	186									
					20					12.9	12.5	12.0	11.6	11.1	10.7	10.0	9.3	8.5	7.8	6.9	6.0	3.4														
					40					11.9	11.5	11.0	10.5	10.0	9.4	8.7	7.9	7.1	6.2	5.2	4.2	2.3														
					60					10.9	10.3	9.8	9.2	8.6	8.0	7.2	6.3	5.3	3.9	1.8																
7 GPM 4F07G10301 4F07G10305	18	1	3	230	0																					560	242									
					20					12.7	12.4	12.1	11.7	11.4	10.9	10.5	10.0	9.5	9.0	8.5	7.4	6.1	4.5	1.6												
					40					12.0	11.7	11.3	10.9	10.6	10.1	9.7	9.2	8.7	7.8	7.5	6.3	4.7	2.1													
					60					11.2	11.0	10.7	10.3	9.9	9.6	9.2	8.8	8.3	7.7	7.1	6.5	5.8	4.9	2.5												
80					10.6	10.2	9.8	9.5	9.1	8.7	8.2	7.8	7.2	6.6	5.9	5.1	4.1	2.8																		

5 GPM • 1/2 HP

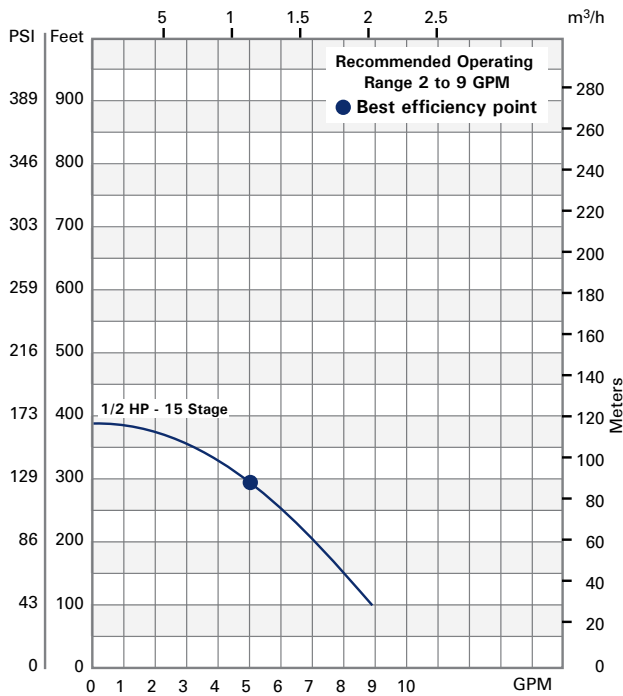

IL1796

7 GPM • 1/2 - 1 HP

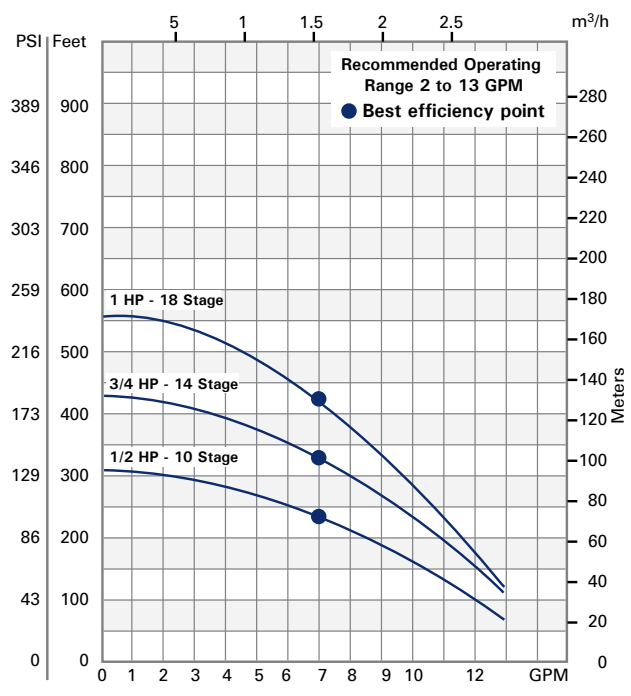

IL1797

* Pumps marked with asterisks not to be operated at GPM flows indicated by dotted lines.

4" 10 GPM • 19 GPM • 3450 RPM • 60 Cycle

Model No.	Stages	HP	Wire	Volts	Discharge Pressure PSI	DEPTH TO WATER LEVEL IN FEET																				Maximum Pressure																												
						20	40	60	80	100	120	140	160	180	200	225	250	275	300	325	350	400	450	500	550	Ft.	PSI																											
						CAPACITIES IN GALLONS PER MINUTE																																																
4F10G05001 4F10G05301 4F10G05005 4F10G05305	8	1/2	3	115 230	0 20 40	14.6	14.1	14.7	14.2	13.4	12.6	11.7	10.8	9.7	8.3	6.3	2.1																								250	108												
4F10G07301 4F10G07305	12	3/4	3 2	230	0 20 40 60 80		14.9	14.5	13.9	13.4	13.0	12.4	11.9	11.4	10.7	9.8	8.9	7.4	6.1	5.7																									375	162								
4F10G10301 4F10G10305	15	1	3 2	230	0 20 40 60 80		14.9	14.5	14.1	13.7	13.3	12.9	12.4	11.9	11.4	10.9	10.3	9.5	8.6	7.9	6.2	4.5	3.8																						470	203								
4F10G15301 4F10G15305	20	1-1/2	3 2	230	0 20 40 60 80		14.1	13.8	13.5	13.2	12.9	12.6	12.2	11.8	11.4	11.0	10.5	10.1	9.6	9.0	8.2	7.4	4.9	4.8	4.1																							630	272					
4F19G10301 4F19G10305	9	1	3 2	230	0 20 40 60 80	25.2	24.0	25.5	24.4	23.2	22.1	20.7	19.4	17.8	16.2	13.7	10.7	5.0																																283	122			
4F19G15301 4F19G15305	12	1-1/2	3 2	230	0 20 40 60 80		24.2	25.2	24.6	23.8	22.9	22.0	21.1	20.1	18.9	17.5	15.1	14.3	11.8	8.7	8.7																																375	163

10 GPM • 1/2 - 1-1/2 HP

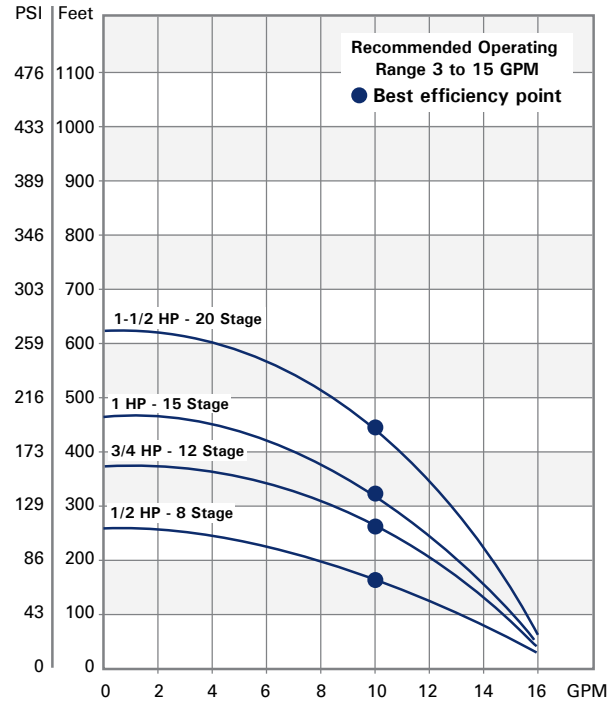

19 GPM • 1 - 1-1/2 HP

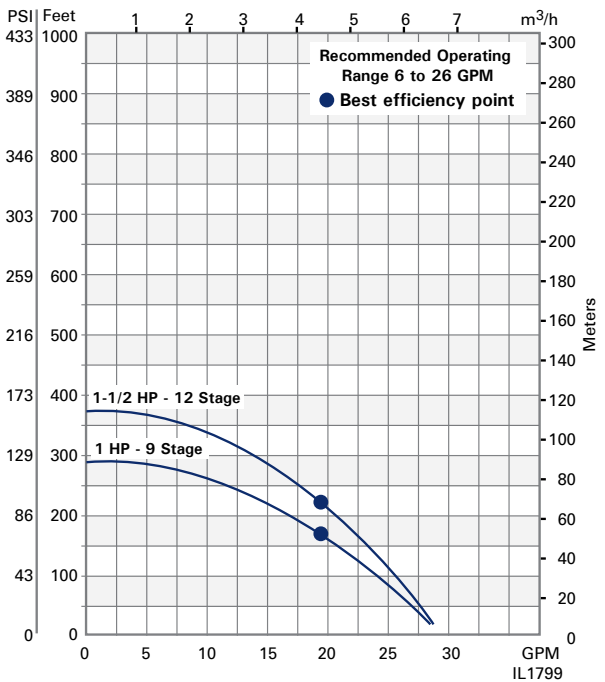

* Pumps marked with asterisks not to be operated at GPM flows indicated by dotted lines.

4" 27 GPM • 3450 RPM • 60 Cycle

Model No.	Stages	HP	Wire	Volts	Discharge Pressure PSI	DEPTH TO WATER LEVEL IN FEET																		Maximum Pressure																	
						20	40	60	80	100	120	140	160	180	200	225	250	275	300	325	350	400	450	500	550	Ft.	PSI														
						CAPACITIES IN GALLONS PER MINUTE																																			
4F27G10301	7	1	3	230	0	20	33	31	34	32	30	27	24	22	18	13	24	22	18	13																				215	93
					20	28	25	23	19	15	5	17	10																												
					40	22	18	13																																	
4F27G10305	10	1-1/2	2	230	0	31	33	32	34	33	31	29	28	26	24	22	17	14	6	24	22	19	17	13															305	132	
					20	31	30	28	27	25	23	21	19	16	11	17	13																								
					40	28	26	24	22	20	18	15	8	8																											

NOTE: Pipe friction loss is not included in chart above.
 Pump/Motor Assembly includes: Pump end, motor and motor leads.
 Order control box separately

27 GPM • 1 - 1-1/2 HP

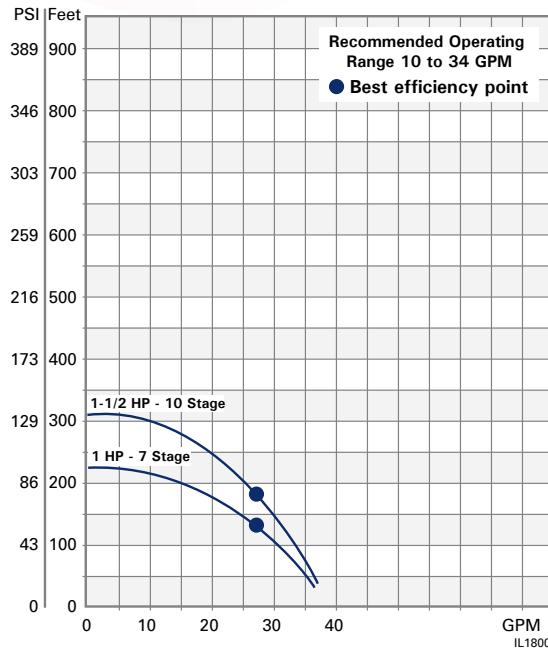

CONTROL BOX FOR 3-WIRE MODELS

Quick-disconnect control box features replaceable snapout cover that keeps all components above ground for easy access and repair.

Order control box separately.

Control box not required for 2-wire models.

Patriot® 4" Submersible



PATRIOT® 4" SUBMERSIBLE

FW1676
1020
Supersedes
0820

1/2, 3/4 and 1 HP

Proven hydraulics and precision engineering make the PATRIOT® an excellent choice for years of dependable service at an affordable price.

Features:

- Made in the USA with a majority of USA content.
- Tested to resist up to 3,500 lbs of pull force
- Glass-filled Noryl® discharge & mounting ring reinforce structural integrity
- Upgraded full staging for improved performance
- Floating impeller stack easily passes debris and prevents damage
- Integrated spider bearing for tighter pump shaft security
- Paired with Flint & Walling's 4" submersible motor



P Series Submersibles



2 wire and 3 wire

115 volt and 230 volt

5, 7, 11, 19 and 27 GPM



Proven Discharge & Mounting Ring

Glass-filled Noryl® material reinforces structural integrity, just like the previous Patriot®.

Sealed Pump Shell

Capable of withstanding 3,500 lbs of pull force, this pump is meant to last.

Upgraded Full Staging

With highly optimized inner-components, expect improved pump performance from the Patriot®.

Foundation you can Trust
 Flint & Walling motors are tested to the core – by people who speak your language.



CONTROL BOX FOR 3-WIRE MODELS

Quick-disconnect control box features replaceable snapout cover that keeps all components above ground for easy access and repair.

Order control box separately.

Control box not required for 2-wire models.

Performance Charts

5 to 27 GPM • 1/2 to 1 HP



5 to 27 GPM • 1/2 to 1 HP

HP Size, GPM and Model No.	Stages	Motor Type	Ship Wt.	Disch. Press. PSI	DEPTH TO WATER LEVEL IN FEET																Maximum Pressure		
					20	40	60	80	100	120	140	160	180	200	225	250	275	300	350	400	450	Ft.	PSI
					CAPACITIES IN GALLONS PER MINUTE																		
1/2 HP 5 GPM 4F05P05	15	1 PH 3 Wire	25	0			8.1	7.7	8.2	7.8	7.5	7.1	6.7	6.3	5.7	5.2	4.5	3.9	2.2	390	168		
				20																			
		1 PH 2 Wire	25	40	8.0	7.6	7.2	6.8	6.4	6.0	5.6	5.1	4.6	4.1	3.3	2.5	1.6						
				60	7.1	6.7	6.3	5.9	5.4	5.0	4.4	3.9	3.3	2.6	1.7								
1/2 HP 7 GPM 4F07P05	10	1 PH 3 Wire	22	0			13.4	12.6	11.8	11.0	10.2	9.3	8.5	7.6	6.4	5.0	3.3		310	134			
				20	13.2	12.3	11.5	10.7	9.9	9.1	8.2	7.3	6.3	5.2	3.5								
		1 PH 2 Wire	22	40	11.3	10.5	9.6	8.8	8.0	7.0	6.0	4.8	3.4										
				60	9.4	8.6	7.7	6.7	5.7	4.4	3.0												
3/4 HP 7 GPM 4F07P07	14	1 PH 3 Wire	27	0			13.1	12.5	12.0	11.4	10.9	10.3	9.8	9.1	8.3	7.6	6.7	4.7	2.1	430	186		
				20	12.2	11.6	11.1	10.5	10.0	9.4	8.9	8.3	7.7	7.0	6.1	5.1	3.9	2.5					
		1 PH 2 Wire	27	40	10.9	10.4	9.8	9.3	8.7	8.1	7.5	6.8	6.0	5.2	4.1	2.8							
				60	9.6	9.1	8.5	7.9	7.2	6.6	5.8	5.0	4.0	3.0									
1/2 HP 11 GPM 4F11P05	8	1 PH 3 Wire	22	0			14.9	13.9	13.0	12.1	11.2	10.3	9.1	7.6	4.6				277	120			
				20	14.6	13.6	12.7	11.8	11.0	10.0	8.7	7.0	4.4										
		1 PH 2 Wire	22	40	12.4	11.6	10.7	9.6	8.2	6.3	3.5												
				60	10.4	9.2	7.7	5.5	2.4														
3/4 HP 11 GPM 4F11P07	12	1 PH 3 Wire	26	0			15.2	14.5	13.9	13.2	12.6	11.9	11.3	10.4	9.4	8.3	7.0	3.5	401	173			
				20		15.0	14.3	13.7	13.0	12.4	11.7	11.1	10.4	9.6	8.5	7.2	5.7	3.8					
		1 PH 2 Wire	26	40	14.1	13.5	12.8	12.2	11.5	10.9	10.1	9.3	8.5	7.5	6.0	4.1							
				60	12.6	12.0	11.3	10.6	9.9	9.1	8.2	7.1	5.9	4.4	2.2								
1 HP 11 GPM 4F11P10	15	1 PH 3 Wire	30	0			14.6	14.1	13.6	13.0	12.5	11.9	11.4	10.7	9.9	9.1	8.2	5.8	2.4	504	218		
				20																			
		1 PH 2 Wire	30	40	14.5	13.9	13.4	12.8	12.3	11.7	11.2	10.6	10.0	9.2	8.3	7.3	6.0	2.7					
				60	13.8	13.2	12.7	12.1	11.6	11.0	10.4	9.8	9.2	8.5	7.5	6.2	4.8	3.0					
3/4 HP 19 GPM 4F19P07	7	1 PH 3 Wire	26	0			23.4	21.9	20.3	18.8	17.0	14.7	11.6	6.9					215	93			
				20	23.0	21.4	19.9	18.3	16.4	13.9	10.3	5.1											
		1 PH 2 Wire	26	40	19.4	17.7	15.7	12.9	8.9														
				60	14.9	11.8	7.3																
1 HP 19 GPM 4F19P10	9	1 PH 3 Wire	27	0			23.7	22.3	20.9	19.7	18.5	17.3	15.9	13.4	9.5				283	122			
				20		23.3	21.8	20.5	19.3	18.2	16.9	15.3	13.2	10.2	4.5								
		1 PH 2 Wire	27	40	21.4	20.1	19.0	17.8	16.5	14.8	12.4	9.0	4.2										
				60	18.6	17.4	16.0	14.1	11.5	7.7													
1 HP 27 GPM 4F27P10	7	1 PH 3 Wire	27	0			31.6	28.9	26.7	25.0	23.6	21.8	18.7	12.8					215	93			
				20	30.8	28.2	26.1	24.5	23.1	21.0	17.2	10.2											
		1 PH 2 Wire	27	40	25.6	24.1	22.6	20.1	15.5	7.1													
				60	22.0	19.0	13.4																

NOTE: Pipe friction loss in drop pipe is not included in chart above.

Pump and motor assembly includes: Pump/motor unit and motor leads. Sta-Kon connectors and rubber electrical tape not included.

MODEL CODE NUMBER

4 F 11 P 05 - 30 1 S

4" Min. Well Diameter

Series

GPM

Material Construction

- A—Cast Iron Castings, Stainless steel Shell
- G—Cast Iron Castings - Powder Coated Steel Shell
- S—Stainless Steel Castings, Stainless steel. Shell
- P—Thermoplastic Housings, Stainless steel. Shell

Motor HP Size

Lead Type
1 — 3-wire
5 — 2-wire

Motor Voltage and Phase
00 — 115 V 1 Ph
30 — 230 V 1 Ph

5 to 27 GPM • 1/2 to 1 HP

5 & 7 GPM

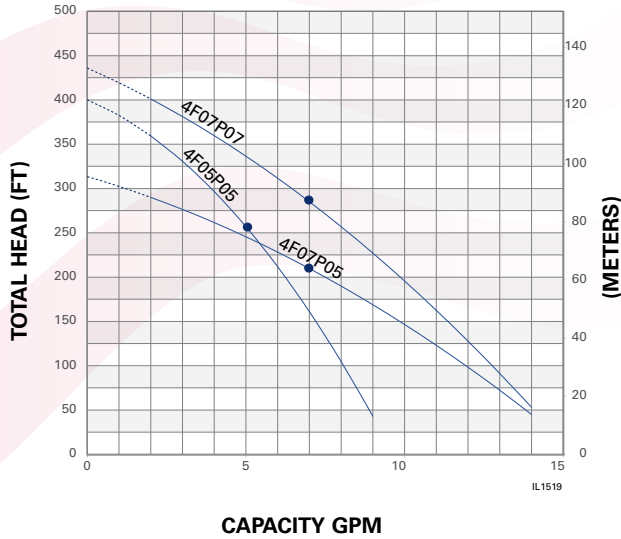

11 GPM

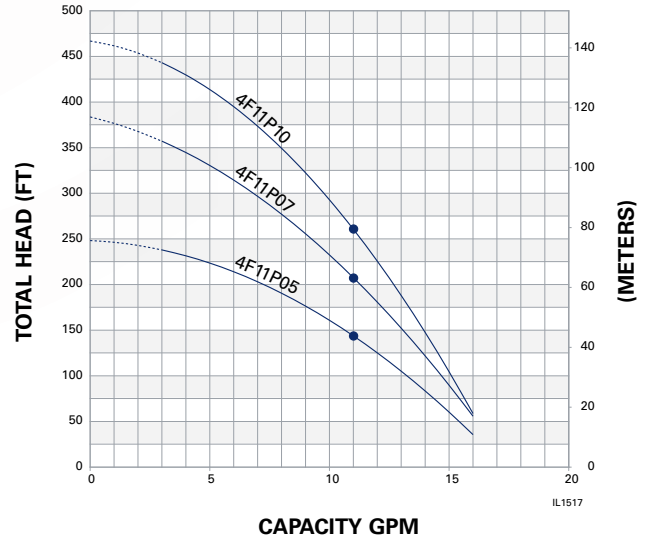

19 and 27 GPM

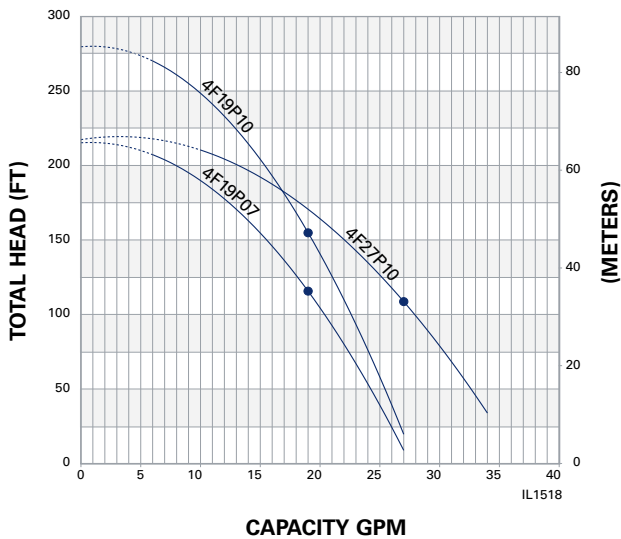

Model	HP	Wire	A - Pump length (in)	B - Motor length (in)
4F05P05	0.5	2 & 3	20.13	10.50
4F07P05	0.5	2 & 3	16.19	10.50
4F07P07	0.75	2 & 3	19.37	11.63
4F11P05	0.5	2 & 3	15.38	10.50
4F11P07	0.75	2 & 3	18.94	11.63
4F11P10	1	2 & 3	21.56	12.50
4F19P07	0.75	2 & 3	15.12	11.63
4F19P10	1	2 & 3	17.06	12.50
4F27P10	1	2 & 3	15.37	12.50

All dimensions are rounded to the nearest 100th of an inch.



PUMP AND MOTOR PROTECTION

FW1680
0820
Supersedes
0518

SINGLE-PHASE PROTECTION SYSTEM

PumpSaver Plus 1/3 - 1-1/2 HP, 3 HP

- For single-phase motors 1/3 - 1-1/2 HP, 3 HP, 230V, 2 or 3-wire
- Protects against low-yield wells, drop in water level, low voltage and dead head
- Manual or auto reset (2 min. - 225 min.)
- Run and fault Indicator lights

PumpSaver Plus 5 - 7.5 HP

- For single-phase motors 5 - 7-1/2 HP, 230V, 2 or 3-wire
- Protects against low-yield wells, drop in water level and low voltage, rapid cycling, water logged tank, jammed impeller and dead head

- Manual or auto reset (2 min. - 225 min.)
- Run and Fault Indicator lights

PumpSaver Insider

- For 3-wire single-phase submersible motors 1/3 - 1 HP 230V
- Protects against low-yield wells, drop in water level, low voltage and dead head
- Auto or manual reset
- Surge resistant
- Moisture and insect resistant
- Solid state electronic circuitry
- Mounts in existing Flint & Walling control box



Control Type	HP	Volts	P/N	Wt.
PumpSaver Insider	1/3 - 1	230	023803	1.0
	1/3 - 1-1/2	230	023804	3.5
PumpSaver Plus	1/3 - 3	230	023805	3.5
	5 - 7-1/2	230	023806	4.0



WP0075
1022
Supersedes
1121

RIGHT PUMP. RIGHT NOW.

Introducing Wolf submersible turbine pumps for 6" and larger wells for Flint & Walling

F&W and Wolf are now offering the full line of Wolf submersible turbine pumps to F&W customers in place of F&W models 6P, 6T and 8T.

F&W distributors can now place orders for Wolf submersibles directly with the Wolf factory. This change will result in lowered costs and leadtimes without sacrificing hydraulic coverage. Those without an active Wolf account can take advantage of this offer by submitting the following three documents

- Credit Application
- Credit Agreement
- Texas Sales and use Tax Resale Certificate (or your state's resale certificate)

These three files can be found on the Wolf website WolfPumps.com on the "Terms of Sale" page under the "About Us" tab or you can scan the QR code below to navigate directly to the documents.



Document link
<https://www.wolfpumps.com/about-us/terms-of-sale/>

Submersible Turbine Pumps for 6" and up Wells



History of Wolf Pump

Bill Wolf and Sons began operations in 1951 as a drilling and pump service company in Abernathy, TX. At that time irrigation was new to the West Texas region but rapidly gaining popularity. After several years of experience with the harsh well conditions and ever-changing water tables in West Texas, Mr. Wolf recognized the need to design, manufacture, and build a pump that was better suited for these applications. This was the start of the Wolf Pump line of submersible turbine pumps. Wolf Pump continues to transition from a regional manufacturing and pump service company to an international supplier of submersible turbine pumps with ever expanding facilities to accommodate growth into new regional and end-user markets.

In 2012, Wolf Pump was purchased by Flint & Walling, a world-wide leader in the pump industry since 1866. Under this organization and with the ability to leverage more sales, marketing, and engineering resources, several significant investments in facilities upgrades, including a state-of-the-art testing laboratory, have been made.

As Wolf grows in the future, customers should expect the same high level of service that they have grown accustomed to over the past several decades, and to be held to the following Covenant that we make with the marketplace.

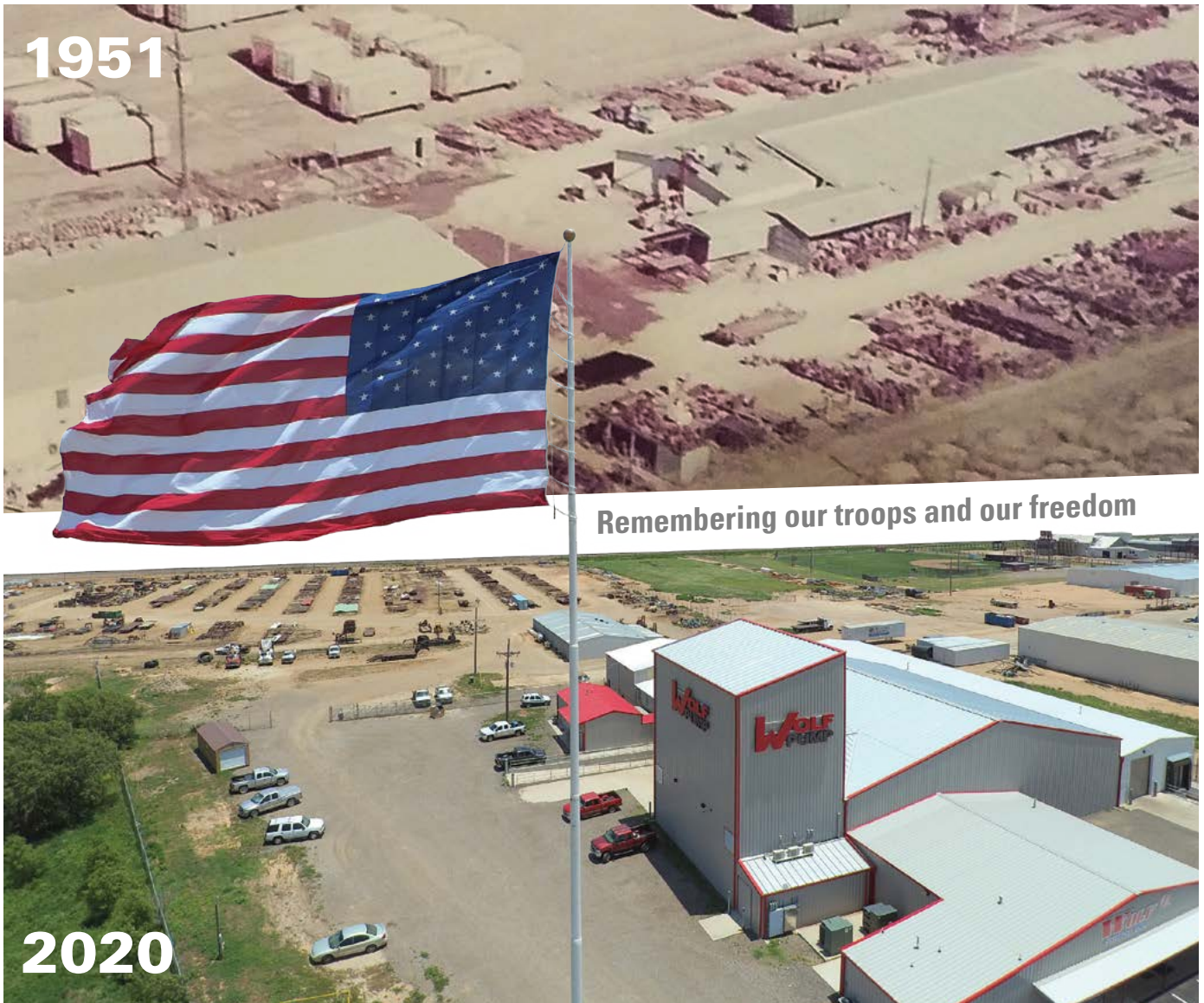

Submersible Turbine Pumps for 6" and up Wells

Wolf Submersible Pump Selections - 6" Min Well Diameter

70 GPM		Wolf Item No	Recommended Operating Range 70GPM - 100GPM								100 GPM		
Model	Total Stages		A Trim Stages	B Trim Stages	C Trim Stages	HP	Head @ 70 GPM	Head @ 80 GPM	Head @ 90 GPM	Head @ 100 GPM	Head @ 85 GPM (BEP)	NOL HP	Shutoff Head
5ML6V A TRIM = 4.515" B TRIM = 4.25" P.E.I. - .99	2	WS5ML6V1-003-85	0	2		3	94	86	76	64	80	3.1	122
	3	WS5ML6V1-005-85	1	2		5	151	139	124	106	131	5.0	191
	4	WS5ML6V1-007-85	4	0		7.5	228	212	192	168	204	7.6	276
	5	WS5ML6V1-010-85	5	0		10	285	265	240	210	255	9.5	346
	6	WS5ML6V2-010-85	3	3		10	312	288	258	222	273	10.3	390
	8	WS5ML6V1-015-85	8	0		15	456	424	384	336	408	15.2	553
	11	WS5ML6V1-020-85	10	1		20	617	573	518	452	550	20.5	752
	13	WS5ML6V1-025-85	13	0		25	741	689	624	546	663	24.7	898
16	WS5ML6V1-030-85	16	0		30	912	848	768	672	816	30.4	1106	
110 GPM		Wolf Item No	Recommended Operating Range 110GPM - 150GPM								150 GPM		
Model	Total Stages		A Trim Stages	B Trim Stages	C Trim Stages	HP	Head @ 110 GPM	Head @ 120 GPM	Head @ 140 GPM	Head @ 150 GPM	130 GPM (BEP)	NOL HP	Shutoff Head
5LL5V A TRIM = 4.125" B TRIM = 4.00" C TRIM = 3.75" P.E.I. - .89	1	WS5LL5V1-003-130	1	0	0	3	51	49	46	43	48	2.5	66
	2	WS5LL5V1-005-130	2	0	0	5	102	98	91	86	95	5.0	132
	4	WS5LL5V1-007-130	0	3	1	7.5	166	159	136	125	148	7.5	227
	4	WS5LL5V1-010-130	4	0	0	10	204	196	182	172	190	10.0	263
	7	WS5LL5V1-015-130	2	5	0	15	322	311	276	256	295	15.0	430
	10	WS5LL5V1-020-130	0	10	0	20	440	425	370	340	400	20.0	596
	11	WS5LL5V1-025-130	9	0	2	25	527	503	460	432	484	25.5	689
	15	WS5LL5V1-030-130	0	15	0	30	660	638	555	510	600	30.0	894
16	WS5LL5V1-040-130	16	0	0	40	816	784	728	688	760	39.8	1053	
120 GPM		Wolf Item No	Recommended Operating Range 120GPM - 170GPM								170 GPM		
Model	Total Stages		A Trim Stages	B Trim Stages	C Trim Stages	HP	Head @ 120 GPM	Head @ 140 GPM	Head @ 160 GPM	Head @ 170 GPM	150 GPM (BEP)	NOL HP	Shutoff Head
5MM6V A TRIM = 4.515" B TRIM = 4.375" C TRIM = 4.31" P.E.I. - .93	2	WS5MM6V1-005-150	0	0	2	5	108	96	82	75	90	5.1	126
	3	WS5MM6V1-007-150	0	0	3	7.5	162	145	125	115	135	7.9	190
	3	WS5MM6V1-010-150	2	1	0	10	197	186	167	155	177	10.4	211
	4	WS5MM6V1-015-150	4	0	0	15	272	260	236	220	248	15.0	287
	6	WS5MM6V1-020-150	4	2	0	20	394	372	333	310	354	20.9	421
	7	WS5MM6V1-025-150	5	2	0	25	462	437	392	365	416	24.6	493
	10	WS5MM6V1-030-150	0	10	0	30	610	560	485	450	530	29.3	673
	11	WS5MM6V1-040-150	10	1	0	40	741	706	639	595	673	40.4	784
14	WS5MM6V1-050-150	13	0	1	50	938	893	808	753	851	51.2	995	
16	WS5MM6V1-060-150	16	0	0	60	1088	1040	944	880	992	60.0	1147	
180 GPM		Wolf Item No	Recommended Operating Range 180GPM - 300GPM								300 GPM		
Model	Total Stages		A Trim Stages	B Trim Stages	C Trim Stages	HP	Head @ 180 GPM	Head @ 210 GPM	Head @ 280 GPM	Head @ 300 GPM	240 GPM (BEP)	NOL HP	Shutoff Head
5HH7V A TRIM = 4.125" B TRIM = 4.00" C TRIM = 3.875" P.E.I. - .93	2	WS5HH7V1-005-240	0	0	2	5	69	64	45	37	55	5.2	89
	2	WS5HH7V1-007-240	2	0	0	7.5	85	80	62	55	73	6.9	102
	3	WS5HH7V1-010-240	3	0	0	10	128	120	93	83	110	10.3	152
	5	WS5HH7V1-015-240	3	0	2	15	197	184	138	120	165	15.5	242
	6	WS5HH7V1-020-240	6	0	0	20	255	240	186	165	219	20.6	305
	8	WS5HH7V1-025-240	6	0	2	25	324	304	231	202	274	25.8	394
	9	WS5HH7V1-030-240	8	0	1	30	375	352	271	239	320	30.0	451
	12	WS5HH7V1-040-240	12	0	0	40	510	480	372	330	438	41.2	610
	15	WS5HH7V1-050-240	14	0	1	50	630	592	457	404	539	50.6	756
	18	WS5HH7V1-060-240	17	0	1	60	757	712	550	486	648	60.9	908
22	WS5HH7V1-075-240	21	1	0	75	931	875	676	599	798	74.9	1113	
280 GPM		Wolf Item No	Recommended Operating Range 280GPM - 460GPM								460 GPM		
Model	Total Stages		A Trim Stages	B Trim Stages	C Trim Stages	HP	Head @ 280 GPM	Head @ 320 GPM	Head @ 400 GPM	Head @ 460 GPM	360 GPM (BEP)	NOL HP	Shutoff Head
5HX7V A TRIM = 4.515" B TRIM = 4.25" P.E.I. - .87	1	WS5HX7V1-007-360	1	0		7.5	48	46	42	34	45	6.6	60
	2	WS5HX7V1-010-360	0	2		10	78	74	63	50	70	11.0	102
	2	WS5HX7V1-015-360	2	0		15	95	92	84	68	90	13.3	120
	3	WS5HX7V2-015-360	0	3		15	117	111	95	75	105	16.5	153
	3	WS5HX7V1-020-360	3	0		20	143	138	126	102	135	19.9	180
	4	WS5HX7V1-025-360	3	1		25	182	175	158	127	170	25.4	231
	5	WS5HX7V1-030-360	3	2		30	221	212	189	152	205	30.9	282
	6	WS5HX7V1-040-360	6	0		40	285	276	252	204	270	39.8	360
	8	WS5HX7V1-050-360	5	3		50	355	341	305	245	330	49.7	453
	9	WS5HX7V1-060-360	9	0		60	428	414	378	306	405	59.7	540
12	WS5HX7V1-075-360	10	2		75	553	534	483	390	520	77.3	702	
15	WS5HX7V1-100-360	15	0		100	713	690	630	510	675	99.5	900	
19	WS5HX7V1-125-360	19	0		125	903	874	798	646	855	126.0	1140	

Submersible Turbine Pumps for 8" and up Wells



Wolf Submersible Pump Selections - 8" Min Well Diameter															
80 GPM		Wolf Item No	Recommended Operating Range 80GPM - 100GPM							100 GPM					
Model	Total Stages		A Trim Stages	B Trim Stages	C Trim Stages	HP	Head @ 80 GPM	Head @ 85 GPM	Head @ 95 GPM	Head @ 100 GPM	Head @ 90 GPM (BEP)	NOL HP	Shutoff Head		
6LL6V	3	WS6LL6V1-005-90	2	1		5	144	135	120	112	130	5.0	190		
	4	WS6LL6V1-007-90	4	0		7.5	211	202	184	172	192	7.1	270		
	6	WS6LL6V1-010-90	6	0		10	317	304	276	260	288	10.2	407		
	9	WS6LL6V1-015-90	9	0		15	475	455	415	387	432	15.3	610		
	12	WS6LL6V1-020-90	12	0		20	635	608	551	516	575	20.4	815		
	15	WS6LL6V1-025-90	15	0		25	792	760	690	645	720	25.6	1017		
A Trim = 4.515" B Trim = 4.250" P.E.I - .93		17	WS6LL6V1-030-90	17	0		30	900	860	780	731	815	29.0	1152	
110 GPM		Wolf Item No	Recommended Operating Range 110GPM - 160GPM							160 GPM					
Model	Total Stages		A Trim Stages	B Trim Stages	C Trim Stages	HP	Head @ 110 GPM	Head @ 125 GPM	Head @ 145 GPM	Head @ 160 GPM	Head @ 150 GPM (BEP)	NOL HP	Shutoff Head		
6LM6V	2	WS6LM6V1-005-150	0	2	0	5	106	98	86	76	82	4.7	122		
	3	WS6LM6V1-007-150	1	2	0	7.5	173	163	147	132	142	7.9	194		
	3	WS6LM6V1-010-150	3	0	0	10	201	195	182	168	180	9.6	215		
	5	WS6LM6V1-015-150	4	0	1	15	310	300	275	250	270	14.5	340		
	7	WS6LM6V1-020-150	5	0	2	20	425	409	371	336	366	20.0	471		
	8	WS6LM6V1-025-150	7	1	0	25	522	504	467	430	461	24.8	562		
	10	WS6LM6V1-030-150	8	2	0	30	642	618	570	524	562	30.3	695		
	13	WS6LM6V1-040-150	12	0	1	40	849	822	760	700	753	40.5	916		
A Trim = 4.4375" B Trim = 4.25" C Trim = 4.0625" P.E.I - .88		16	WS6LM6V1-050-150	15	1	0	50	1058	1024	950.5	878	941	50.5	1135	
140 GPM		Wolf Item No	Recommended Operating Range 140GPM - 220GPM							220 GPM					
Model	Total Stages		A Trim Stages	B Trim Stages	C Trim Stages	HP	Head @ 140 GPM	Head @ 170 GPM	Head @ 200 GPM	Head @ 220 GPM	Head @ 189 GPM (BEP)	NOL HP	Shutoff Head		
6LH6V	1	WS6LH6V1-005-190	0	1		5	60	56	49	45	51	4.1	60		
	1	WS6LH6V1-007-190	1	0		7.5	76	73	67	63	70	5.8	77		
	2	WS6LH6V1-010-190	1	1		10	131	125	113	104	118	9.9	135		
	3	WS6LH6V1-015-190	1	2		15	199	188	168	156	175	14.0	197		
	4	WS6LH6V1-020-190	1	3		20	265	248	225	204	232	18.1	270		
	5	WS6LH6V1-025-190	3	2		25	357	340	308	288	321	25.5	351		
	6	WS6LH6V1-030-190	4	2		30	436	416	378	354	394	31.2	428		
	7	WS6LH6V1-040-190	7	0		40	553	532	490	462	511	40.3	539		
	9	WS6LH6V1-050-190	8	1		50	692	664	609	573	635	50.1	676		
	A Trim = 4.515" B Trim = 4.187" P.E.I - .93		11	WS6LH6V1-060-190	10	1		60	850	816	749	705	781	61.6	830
230 GPM		Wolf Item No	Recommended Operating Range 230GPM - 320GPM							320 GPM					
Model	Total Stages		A Trim Stages	B Trim Stages	C Trim Stages	HP	Head @ 230 GPM	Head @ 260 GPM	Head @ 280 GPM	Head @ 320 GPM	Head @ 300 GPM (BEP)	NOL HP	Shutoff Head		
6MM8V	1	WS6MM8V1-005-300	0	0	1	5	41	37	35	27	30	5.0	60		
	1	WS6MM8V1-007-300	1	0	0	7.5	58	55	54	50	53	7.0	82		
	2	WS6MM8V1-010-300	0	0	2	10	98	88	85	70	80	9.0	125		
	3	WS6MM8V1-015-300	0	0	3	15	150	136	132	118	130	14.0	195		
	3	WS6MM8V1-020-300	3	0	0	20	219	210	204	186	195	20.3	270		
	4	WS6MM8V1-025-300	3	0	1	25	270	256	246	222	235	24.5	338		
	5	WS6MM8V1-030-300	3	0	2	30	325	308	295	264	280	29.0	406		
	6	WS6MM8V1-040-300	6	0	0	40	438	420	408	372	390	40.6	540		
	7	WS6MM8V1-050-300	7	0	0	50	511	490	476	434	455	47.4	630		
	9	WS6MM8V1-060-300	8	1	0	60	652	624	606	551	580	60.3	807		
	A Trim = 4.75" B Trim = 4.625" C Trim = 4.375" P.E.I - .87		11	WS6MM8V1-075-300	11	0	0	75	803	770	748	682	715	74.5	990
320GPM		Wolf Item No	Recommended Operating Range 320GPM - 420GPM							420GPM					
Model	Total Stages		A Trim Stages	B Trim Stages	C Trim Stages	HP	Head @ 320 GPM	Head @ 350 GPM	Head @ 400 GPM	Head @ 420 GPM	Head @ 370 GPM (BEP)	NOL HP	Shutoff Head		
6HH7V	1	WS6HH7V1-007-370	0	1	0	7.5	54	52	47	45	50	7.2	70		
	1	WS6HH7V1-010-370	1	0	0	10	66	62	55	51	59	8.9	88		
	2	WS6HH7V1-015-370	1	0	1	15	108	103	93	86	99	14.5	142		
	3	WS6HH7V1-020-370	1	0	2	20	150	144	131	121	139	20.2	196		
	3	WS6HH7V1-025-370	2	1	0	25	186	176	157	147	168	25.0	246		
	4	WS6HH7V1-030-370	2	1	1	30	228	217	195	182	208	30.7	300		
	5	WS6HH7V1-040-370	4	0	1	40	306	289	258	239	276	41.2	406		
	6	WS6HH7V1-050-370	5	0	1	50	372	351	313	290	335	50.1	494		
	7	WS6HH7V1-060-370	6	1	0	60	450	424	377	351	404	60.6	598		
	9	WS6HH7V1-075-370	8	0	1	75	570	537	478	443	512	76.8	758		
	A Trim = 4.515" B Trim = 4.25" C Trim = 4.0" P.E.I - .99		12	WS6HH7V1-100-370	11	0	1	100	768	723	643	596	689	103.5	1022

Submersible Turbine Pumps for 8" and up Wells

Wolf Submersible Pump Selections - 8" Min Well Diameter													
440GPM		Wolf Item No	Recommended Operating Range 440GPM - 540GPM							540GPM			
Model	Total Stages		A Trim Stages	B Trim Stages	C Trim Stages	HP	Head @ 440 GPM	Head @ 475 GPM	Head @ 525 GPM	Head @ 540 GPM	Head @ 504 GPM (BEP)	NOL HP	Shutoff Head
7MH5V	1	WS7MH5V1-007-500	0	0	1	7.5	43	39	31	29	35	7.2	78
	1	WS7MH5V1-010-500	0	1	0	10	60	56	48	46	51	9.3	90
	2	WS7MH5V1-015-500	0	0	2	15	86	78	62	58	70	14.4	156
	2	WS7MH5V1-020-500	1	0	1	20	114	107	93	87	99	19.1	184
	2	WS7MH5V1-025-500	2	0	0	25	142	136	124	116	128	23.8	212
	3	WS7MH5V1-030-500	1	2	0	30	191	180	158	150	166	30.6	286
	4	WS7MH5V1-040-500	2	0	2	40	228	214	186	174	198	38.2	368
	5	WS7MH5V1-050-500	3	0	2	50	299	282	248	232	262	50.1	474
	5	WS7MH5V1-060-500	5	0	0	60	355	340	310	290	320	59.5	530
7	WS7MH5V1-075-500	5	0	2	75	441	418	372	348	390	73.9	686	
9	WS7MH5V1-100-500	7	0	2	100	583	554	496	464	518	97.7	898	
560GPM		Wolf Item No	Recommended Operating Range 560GPM - 740GPM							740GPM			
Model	Total Stages		A Trim Stages	B Trim Stages	C Trim Stages	HP	Head @ 560 GPM	Head @ 600 GPM	Head @ 650 GPM	Head @ 740 GPM	Head @ 701 GPM (BEP)	NOL HP	Shutoff Head
7MH7V	1	WS7MH7V1-015-700	0	1	0	15	50	47	44	36	40	15.5	80
	1	WS7MH7V1-020-700	1	0	0	20	61	59	57	50	54	19.0	94
	2	WS7MH7V1-025-700	0	0	2	25	96	90	82	66	73	24.0	150
	2	WS7MH7V1-030-700	0	2	0	30	113	109	102	84	91	27.5	169
	2	WS7MH7V1-040-700	2	0	0	40	143	141	136	122	129	37.0	195
	4	WS7MH7V1-050-700	0	4	0	50	237	230	220	180	194	50.4	340
	4	WS7MH7V1-060-700	2	2	0	60	270	262	250	216	232	59.8	370
	5	WS7MH7V1-075-700	3	2	0	75	346	336	322	281	300	77.1	470
	6	WS7MH7V1-100-700	5	1	0	100	439	427	413	368	388	99.1	585
7	WS7MH7V1-125-700	7	0	0	125	532	518	504	455	476	121.0	700	
9	WS7MH7V1-150-700	8	1	0	150	667	649	629	563	592	151.0	885	

Wolf Model No. Codes

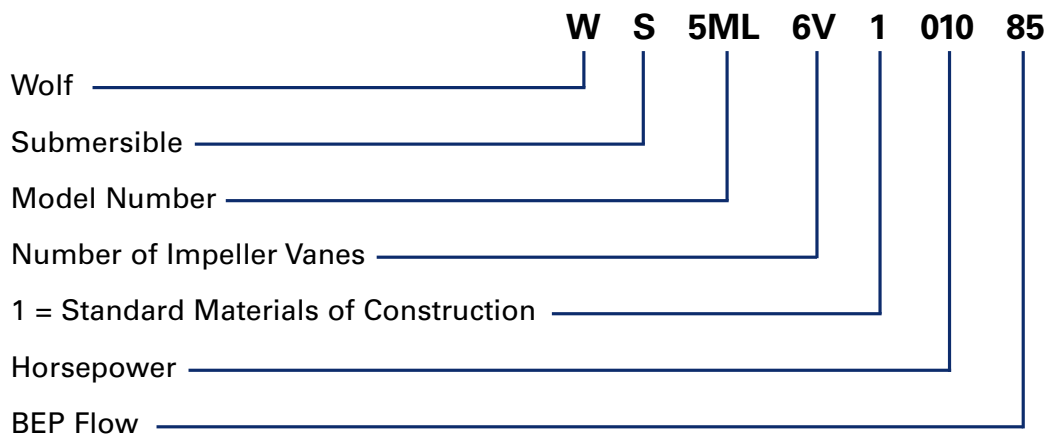

Submersible Turbine Pumps for 10" and up Wells



Wolf Submersible Pump Selections - 10" Min Well Diameter													
320 GPM		Wolf Item No	Recommended Operating Range 320GPM - 480GPM							480 GPM			
Model	Total Stages		A Trim Stages	B Trim Stages	C Trim Stages	HP	Head @ 320 GPM	Head @ 360 GPM	Head @ 440 GPM	Head @ 480 GPM	Head @ 400 GPM (BEP)	NOL HP	Shutoff Head
8LL4V	1	WS8LL4V1-010-400	0	0	1	10	65	58	na	na	50	9.7	117
	1	WS8LL4V1-015-400	1	0	0	15	94	88	72	61	83	14.6	146
	2	WS8LL4V1-020-400	0	1	1	20	153	135	100	77	120	20.0	250
	2	WS8LL4V1-025-400	1	1	0	25	174	158	127	105	145	25.3	275
	2	WS8LL4V1-030-400	2	0	0	30	209	197	161	138	178	29.2	300
	4	WS8LL4V1-040-400	0	4	0	40	346	310	236	195	280	40.0	545
A Trim = 6.45"	4	WS8LL4V1-050-400	3	1	0	50	410	385	309	260	350	51.0	610
B Trim = 6.0"	5	WS8LL4V1-060-400	4	0	1	60	476	445	365	295	428	63.5	752
C Trim = 5.75"	6	WS8LL4V1-075-400	5	0	1	75	577	540	445	360	521	77.5	910
350 GPM		Wolf Item No	Recommended Operating Range 350GPM - 525GPM							525 GPM			
Model	Total Stages		A Trim Stages	B Trim Stages	C Trim Stages	HP	Head @ 350 GPM	Head @ 400 GPM	Head @ 475 GPM	Head @ 525 GPM	Head @ 425 GPM (BEP)	NOL HP	Shutoff Head
8LL8V	1	WS8LL8V1-015-425	0	1	0	15	98	92	78	68	88	15.0	118
	1	WS8LL8V1-020-425	1	0	0	20	124	119	108	99	115	21.5	152
	2	WS8LL8V1-025-425	0	0	2	25	185	170	140	117	160	25.4	232
	2	WS8LL8V1-030-425	0	2	0	30	218	205	173	150	194	30.0	260
	2	WS8LL8V1-040-425	2	0	0	40	286	270	240	220	262	41.6	322
	3	WS8LL8V1-050-425	1	2	0	50	375	353	304	270	337	50.6	437
A Trim = 6.45"	3	WS8LL8V1-060-425	3	0	0	60	429	405	360	330	393	64.0	483
B Trim = 5.937"	4	WS8LL8V1-075-425	3	0	1	75	532	500	438	394	483	75.1	607
C Trim = 5.687"	5	WS8LL8V1-100-425	5	0	0	100	715	675	600	550	655	104.0	805
6	WS8LL8V1-125-425	6	0	0	125	858	810	720	660	786	124.8	966	
440 GPM		Wolf Item No	Recommended Operating Range 440GPM - 660GPM							660 GPM			
Model	Total Stages		A Trim Stages	B Trim Stages	C Trim Stages	HP	Head @ 440 GPM	Head @ 480 GPM	Head @ 640 GPM	Head @ 660 GPM	Head @ 560 GPM (BEP)	NOL HP	Shutoff Head
8MM5V	1	WS8MM5V1-015-560	0	1	0	15	85	80	58	53	70	15.9	117
	2	WS8MM5V1-020-560	0	0	2	20	122	115	60	53	85	20.0	191
	2	WS8MM5V1-025-560	0	1	1	25	150	143	94	89	120	25.0	220
	2	WS8MM5V1-030-560	0	2	0	30	182	175	127	120	152	30.0	245
	2	WS8MM5V1-040-560	1	1	0	40	216	210	171	164	190	38.5	280
	2	WS8MM5V1-050-560	2	0	0	50	250	244	215	208	228	48.0	316
A Trim = 6.45"	3	WS8MM5V2-050-560	1	2	0	50	320	310	245	225	281	53.0	415
B Trim = 5.937"	3	WS8MM5V1-060-560	2	1	0	60	356	341	276	250	313	63.0	462
C Trim = 5.50"	3	WS8MM5V1-075-560	3	0	0	75	385	379	331	325	356	76.0	470
4	WS8MM5V1-100-560	4	0	0	100	530	520	460	450	490	99.0	650	
5	WS8MM5V1-125-560	5	0	0	125	663	650	570	560	610	123.0	810	
575 GPM		Wolf Item No	Recommended Operating Range 575GPM - 850GPM							850 GPM			
Model	Total Stages		A Trim Stages	B Trim Stages	C Trim Stages	HP	Head @ 575 GPM	Head @ 675 GPM	Head @ 800 GPM	Head @ 850 GPM	Head @ 750 GPM (BEP)	NOL HP	Shutoff Head
8MM7V	1	WS8MM7V1-025-750	0	0	1	25	99	92	79	72	85	26.5	126
	1	WS8MM7V1-030-750	0	1	0	30	111	100	90	83	97	30.1	138
	1	WS8MM7V1-040-750	1	0	0	40	130	122	113	109	115	38.0	160
	2	WS8MM7V1-050-750	0	0	2	50	222	203	173	164	190	50.0	262
	2	WS8MM7V1-060-750	1	0	1	60	250	236	214	205	225	62.0	283
	3	WS8MM7V1-075-750	0	0	3	75	350	327	282	265	303	78.0	400
A Trim = 6.45"	3	WS8MM7V1-100-750	3	0	0	100	425	405	381	369	390	106.0	477
B Trim = 6.187"	4	WS8MM7V1-125-750	1	3	0	125	548	521	479	461	499	130.0	622
C Trim = 6.0"	4	WS8MM7V1-150-750	4	0	0	150	584	556	524	508	540	140.0	656
5	WS8MM7V2-150-750	3	0	2	150	678	641	587	563	613	157.0	765	
5	WS8MM7V1-200-750	5	0	0	200	861	819	766	741	792	205.0	970	

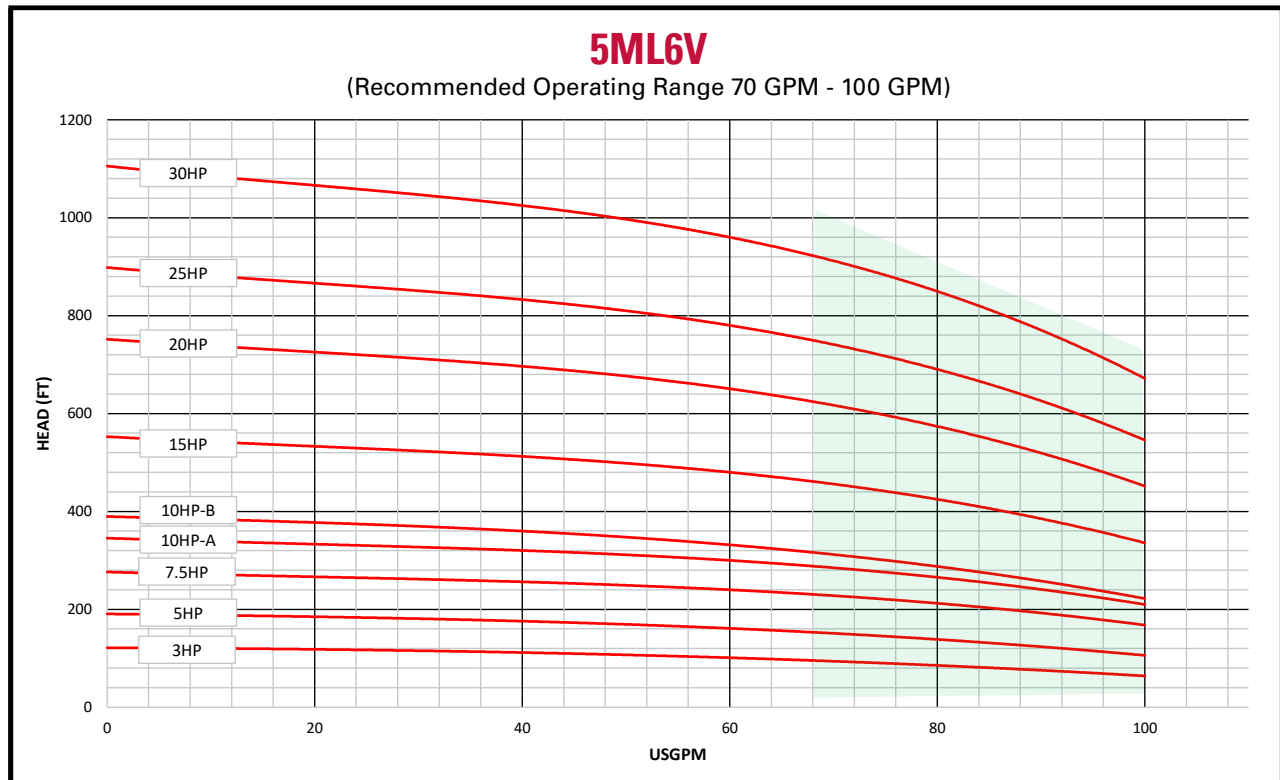

70 GPM		Wolf Item No	Recommended Operating Range 70GPM - 100GPM								100 GPM			
Model	Total Stages		A Trim Stages	B Trim Stages	C Trim Stages	HP	Head @ 70 GPM	Head @ 80 GPM	Head @ 90 GPM	Head @ 100 GPM	Head @ 85 GPM (BEP)	NOL HP	Shutoff Head	
5ML6V	2	WS5ML6V1-003-85	0	2		3	94	86	76	64	80	3.1	122	
	3	WS5ML6V1-005-85	1	2		5	151	139	124	106	131	5.0	191	
	4	WS5ML6V1-007-85	4	0		7.5	228	212	192	168	204	7.6	276	
	5	WS5ML6V1-010-85	5	0		10	285	265	240	210	255	9.5	346	
	6	WS5ML6V2-010-85	3	3		10	312	288	258	222	273	10.3	390	
	8	WS5ML6V1-015-85	8	0		15	456	424	384	336	408	15.2	553	
	11	WS5ML6V1-020-85	10	1		20	617	573	518	452	550	20.5	752	
	13	WS5ML6V1-025-85	13	0		25	741	689	624	546	663	24.7	898	
P.E.I - .99		16	WS5ML6V1-030-85	16	0		30	912	848	768	672	816	30.4	1106

Total Stages	HP	Weight (lbs)	Length (inches)	Standard Materials of Construction		Available Discharge Sizes (NPT)	Upgraded Bushing Material Options	Upgraded Shaft Material Options
2	3	65	22.03	Motor bracket	Ductile Iron	3", 4" (specify with order)	Vesconite	316SS, Chrome, Ion
3	5	81	26.9	Int. Bowl	Cast Iron (lined)			
4	7.5	97	31.78	Discharge	Ductile Iron			
5	10	113	36.65	Impeller	Bronze			
6	10	129	41.53	Bushing	Bronze or rubber			
8	15	161	51.28	Collet	Stainless Steel			
11	20	209	65.9	Fasteners	Stainless Steel			
13	25	241	75.65	Shaft	416SS			
16	30	289	90.28	Sand Collar	Bronze			

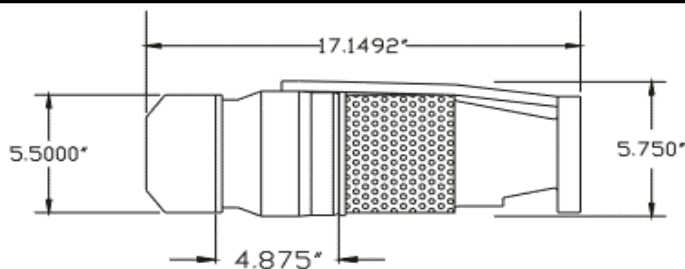

Important Note(s):

Charted performance is based upon 3450rpm, and is guaranteed to ANSI/HI 14.6 acceptance grade 2B within the preferred operating range window indicated on the curve above.

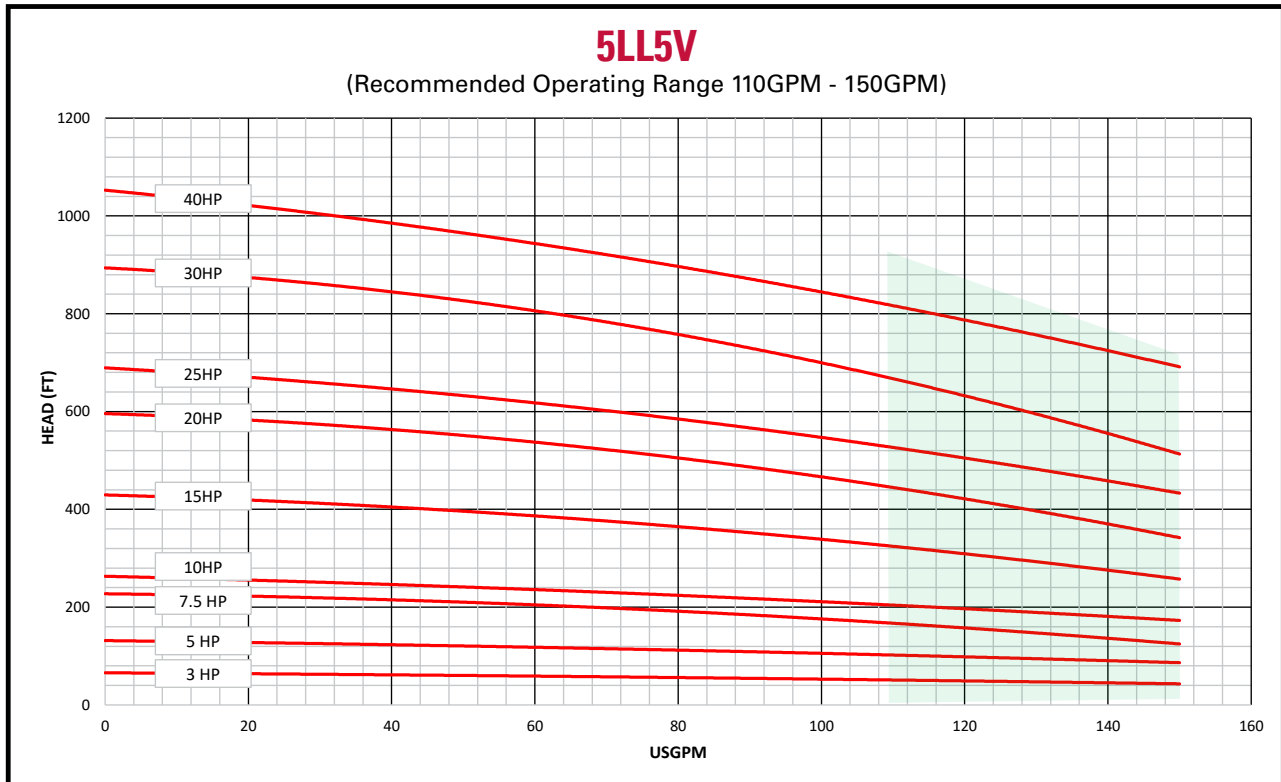

110 GPM		Wolf Item No	Recommended Operating Range 110GPM - 150GPM								150 GPM		
Model	Total Stages		A Trim Stages	B Trim Stages	C Trim Stages	HP	Head @ 110 GPM	Head @ 120 GPM	Head @ 140 GPM	Head @ 150 GPM	130 GPM (BEP)	NOL HP	Shutoff Head
5LL5V	1	WS5LL5V1-003-130	1	0	0	3	51	49	46	43	48	2.5	66
	2	WS5LL5V1-005-130	2	0	0	5	102	98	91	86	95	5.0	132
	4	WS5LL5V1-007-130	0	3	1	7.5	166	159	136	125	148	7.5	227
	4	WS5LL5V1-010-130	4	0	0	10	204	196	182	172	190	10.0	263
	7	WS5LL5V1-015-130	2	5	0	15	322	311	276	256	295	15.0	430
	10	WS5LL5V1-020-130	0	10	0	20	440	425	370	340	400	20.0	596
	11	WS5LL5V1-025-130	9	0	2	25	527	503	460	432	484	25.5	689
	15	WS5LL5V1-030-130	0	15	0	30	660	638	555	510	600	30.0	894
A TRIM = 4.125"		16	WS5LL5V1-040-130	16	0	0	40	816	784	728	688	39.8	1053
B TRIM = 4.00"													
C TRIM = 3.75"													
P.E.I. -.89													

Total Stages	HP	Weight (lbs)	Length (inches)	Standard Materials of Construction		Available Discharge Sizes (NPT)	Upgraded Bushing Material Options	Upgraded Shaft Material Options
1	3	50	18	Motor bracket	Ductile Iron	3", 4" (specify with order)	Vesconite	316SS, Chrome, Ion
2	5	64	22.63	Int. Bowl	Cast Iron (lined)			
4	7.5	92	31.88	Discharge	Ductile Iron			
4	10	92	31.88	Impeller	Stainless Steel			
7	15	134	45.75	Bushing	Bronze or rubber			
10	20	176	59.63	Collet	Stainless Steel			
11	25	190	64.25	Fasteners	Stainless Steel			
15	30	246	82.75	Shaft	416SS			
16	40	260	87.38	Sand Collar	Bronze			

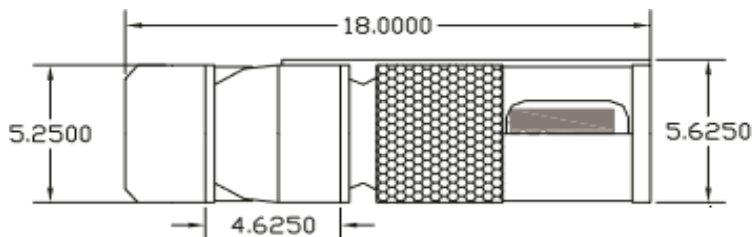

Important Note(s):
 Charted performance is based upon 3450rpm, and is guaranteed to ANSI/HI 14.6 acceptance grade 2B within the preferred operating range window indicated on the curve above.

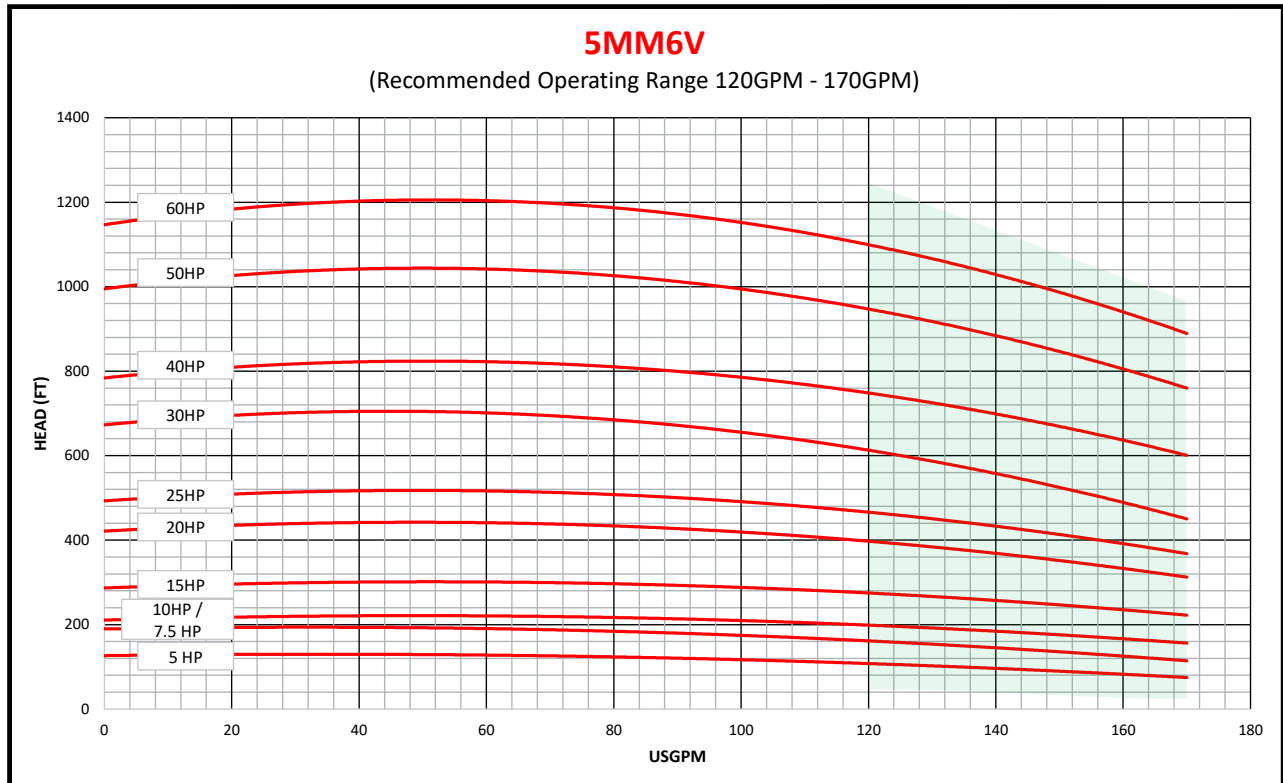

120 GPM		Wolf Item No	Recommended Operating Range 120GPM - 170GPM								170 GPM		
Model	Total Stages		A Trim Stages	B Trim Stages	C Trim Stages	HP	Head @ 120 GPM	Head @ 140 GPM	Head @ 160 GPM	Head @ 170 GPM	150 GPM (BEP)	NOL HP	Shutoff Head
5MM6V	2	WS5MM6V1-005-150	0	0	2	5	108	96	82	75	90	5.1	126
	3	WS5MM6V1-007-150	0	0	3	7.5	162	145	125	115	135	7.9	190
	3	WS5MM6V1-010-150	2	1	0	10	197	186	167	155	177	10.4	211
	4	WS5MM6V1-015-150	4	0	0	15	272	260	236	220	248	15.0	287
	6	WS5MM6V1-020-150	4	2	0	20	394	372	333	310	354	20.9	421
	7	WS5MM6V1-025-150	5	2	0	25	462	437	392	365	416	24.6	493
	10	WS5MM6V1-030-150	0	10	0	30	610	560	485	450	530	29.3	673
	11	WS5MM6V1-040-150	10	1	0	40	741	706	639	595	673	40.4	784
	14	WS5MM6V1-050-150	13	0	1	50	938	893	808	753	851	51.2	995
	16	WS5MM6V1-060-150	16	0	0	60	1088	1040	944	880	992	60.0	1147

A TRIM = 4.515"
B TRIM = 4.375"
C TRIM = 4.31"
P.E.I. - .93

Total Stages	HP	Weight (lbs)	Length (inches)	Standard Materials of Construction		Available Discharge Sizes (NPT)	Upgraded Bushing Material Options	Upgraded Shaft Material Options
2	5	65	22.03	Motor bracket	Ductile Iron	3", 4" (specify with order)	Vesconite	316SS, Chrome, Ion
3	7.5	81	26.91	Int. Bowl	Cast Iron (lined)			
3	10	81	26.91	Discharge	Ductile Iron			
4	15	97	31.79	Impeller	Stainless Steel			
6	20	129	41.55	Bushing	Bronze or rubber			
7	25	145	46.43	Collet	Stainless Steel			
10	30	193	61.06	Fasteners	Stainless Steel			
11	40	209	65.95	Shaft	416SS			
14	50	257	80.6	Sand Collar	Bronze			
16	60	289	90.35					

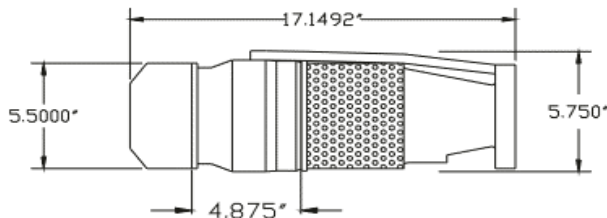

Important Note(s):
 Charted performance is based upon 3450rpm, and is guaranteed to ANSI/HI 14.6 acceptance grade 2B within the preferred operating range window indicated on the curve above.

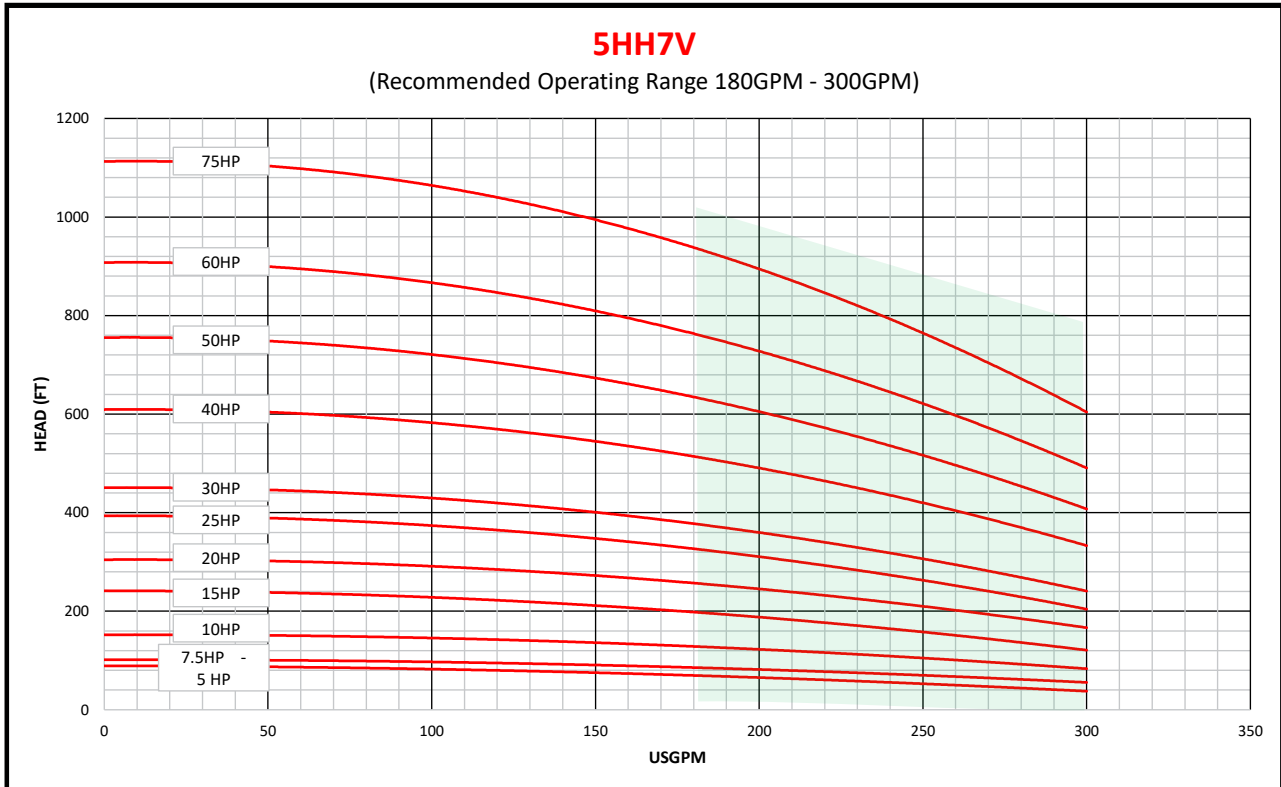

180 GPM		Wolf Item No	Recommended Operating Range 180GPM - 300GPM								300 GPM		
Model	Total Stages		A Trim Stages	B Trim Stages	C Trim Stages	HP	Head @ 180 GPM	Head @ 210 GPM	Head @ 280 GPM	Head @ 300 GPM	240 GPM (BEP)	NOL HP	Shutoff Head
5HH7V	2	WS5HH7V1-005-240	0	0	2	5	69	64	45	37	55	5.2	89
	2	WS5HH7V1-007-240	2	0	0	7.5	85	80	62	55	73	6.9	102
	3	WS5HH7V1-010-240	3	0	0	10	128	120	93	83	110	10.3	152
	5	WS5HH7V1-015-240	3	0	2	15	197	184	138	120	165	15.5	242
	6	WS5HH7V1-020-240	6	0	0	20	255	240	186	165	219	20.6	305
	8	WS5HH7V1-025-240	6	0	2	25	324	304	231	202	274	25.8	394
	9	WS5HH7V1-030-240	8	0	1	30	375	352	271	239	320	30.0	451
	12	WS5HH7V1-040-240	12	0	0	40	510	480	372	330	438	41.2	610
	15	WS5HH7V1-050-240	14	0	1	50	630	592	457	404	539	50.6	756
	18	WS5HH7V1-060-240	17	0	1	60	757	712	550	486	648	60.9	908
P.E.I - .93		22	WS5HH7V1-075-240	21	1	0	75	931	875	676	599	74.9	1113

Total Stages	HP	Weight (lbs)	Length (inches)	Standard Materials of Construction		Available Discharge Sizes (NPT)	Upgraded Bushing Material Options	Upgraded Shaft Material Options
2	5	64	23.13	Motor bracket	Ductile Iron	3", 4" (specify with order)	Vesconite	316SS, Chrome, Ion
2	7.5	64	23.13	Int. Bowl	Cast Iron (lined)			
3	10	78	28	Discharge	Ductile Iron			
5	15	106	37.77	Impeller	Stainless Steel			
6	20	120	42.65	Bushing	Bronze or rubber			
8	25	148	52.41	Collet	Stainless Steel			
9	30	162	57.29	Fasteners	Stainless Steel			
12	40	204	71.93	Shaft	416SS			
15	50	246	86.57	Sand Collar	Bronze			
18	60	288	101.21					
22	75	344	120.73					

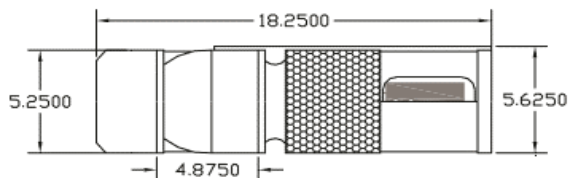

Important Note(s):
 Charted performance is based upon 3450rpm, and is guaranteed to ANSI/HI 14.6 acceptance grade 2B within the preferred operating range window indicated on the curve above.

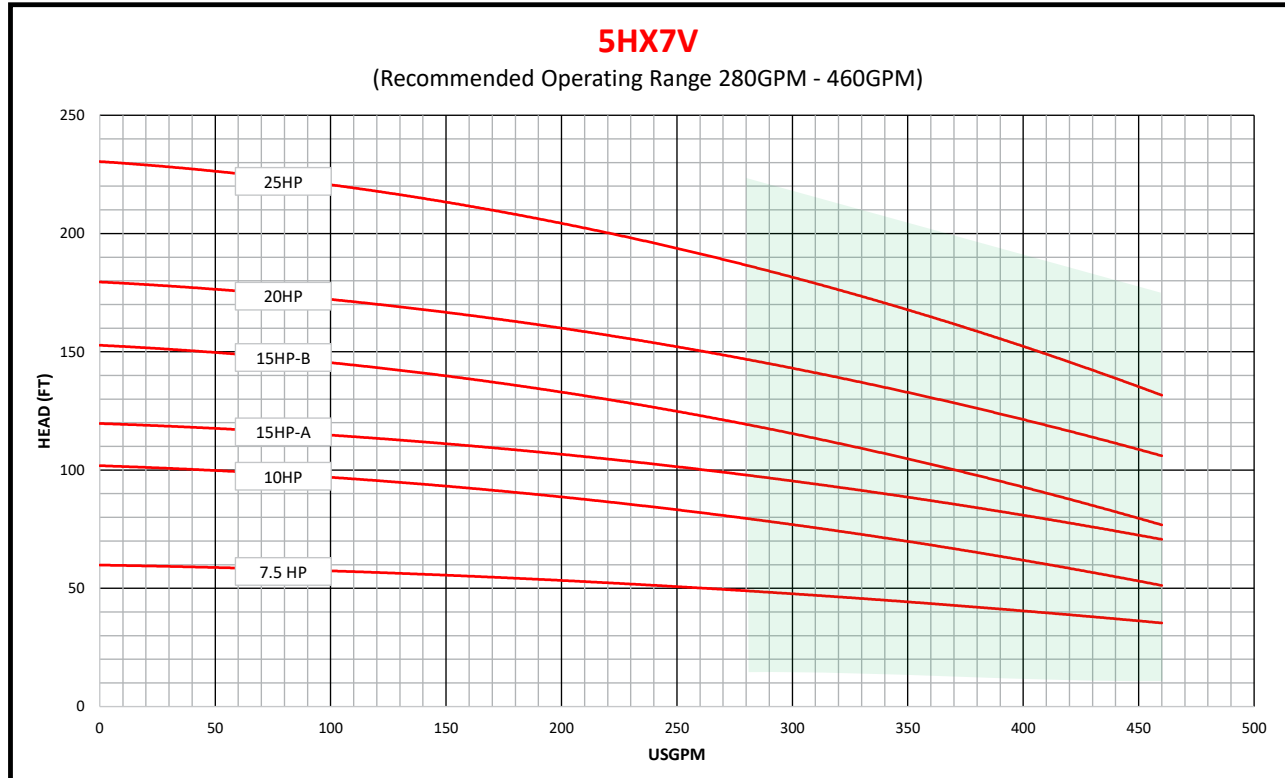

280 GPM		Wolf Item No	Recommended Operating Range 280GPM - 460GPM								460 GPM		
Model	Total Stages		A Trim Stages	B Trim Stages	C Trim Stages	HP	Head @ 280 GPM	Head @ 320 GPM	Head @ 400 GPM	Head @ 460 GPM	360 GPM (BEP)	NOL HP	Shutoff Head
5HX7V	1	WS5HX7V1-007-360	1	0		7.5	48	46	42	34	45	6.6	60
	2	WS5HX7V1-010-360	0	2		10	78	74	63	50	70	11.0	102
	2	WS5HX7V1-015-360	2	0		15	95	92	84	68	90	13.3	120
	3	WS5HX7V2-015-360	0	3		15	117	111	95	75	105	16.5	153
	3	WS5HX7V1-020-360	3	0		20	143	138	126	102	135	19.9	180
	4	WS5HX7V1-025-360	3	1		25	182	175	158	127	170	25.4	231
	5	WS5HX7V1-030-360	3	2		30	221	212	189	152	205	30.9	282
	6	WS5HX7V1-040-360	6	0		40	285	276	252	204	270	39.8	360
	8	WS5HX7V1-050-360	5	3		50	355	341	305	245	330	49.7	453
	9	WS5HX7V1-060-360	9	0		60	428	414	378	306	405	59.7	540
	12	WS5HX7V1-075-360	10	2		75	553	534	483	390	520	77.3	702
	15	WS5HX7V1-100-360	15	0		100	713	690	630	510	675	99.5	900
	19	WS5HX7V1-125-360	19	0		125	903	874	798	646	855	126.0	1140
P.E.I - .87													
Total Stages	HP	Weight (lbs)	Length (inches)	Standard Materials of Construction		Available Discharge Sizes (NPT)		Upgraded Bushing Material Options		Upgraded Shaft Material Options			
1	7.5	50	19.1	Motor bracket	Ductile Iron	3", 4" (specify with order)	Vesconite	316SS, Chrome, Ion					
2	10	70	25.85	Int. Bowl	Cast Iron (lined)								
2	15	70	25.85	Discharge	Ductile Iron								
3	15	90	32.6	Impeller	Bronze								
3	20	90	32.6	Bushing	Bronze or rubber								
4	25	110	39.35	Collet	Stainless Steel								
				Fasteners	Stainless Steel								
				Shaft	416SS								
				Sand Collar	Bronze								

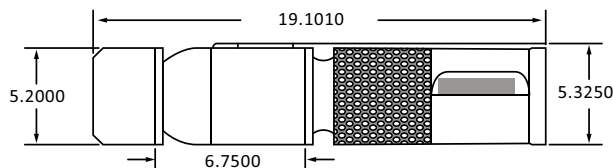

Important Note(s):
 Charted performance is based upon 3450rpm, and is guaranteed to ANSI/HI 14.6 acceptance grade 2B within the preferred operating range window indicated on the curve above.

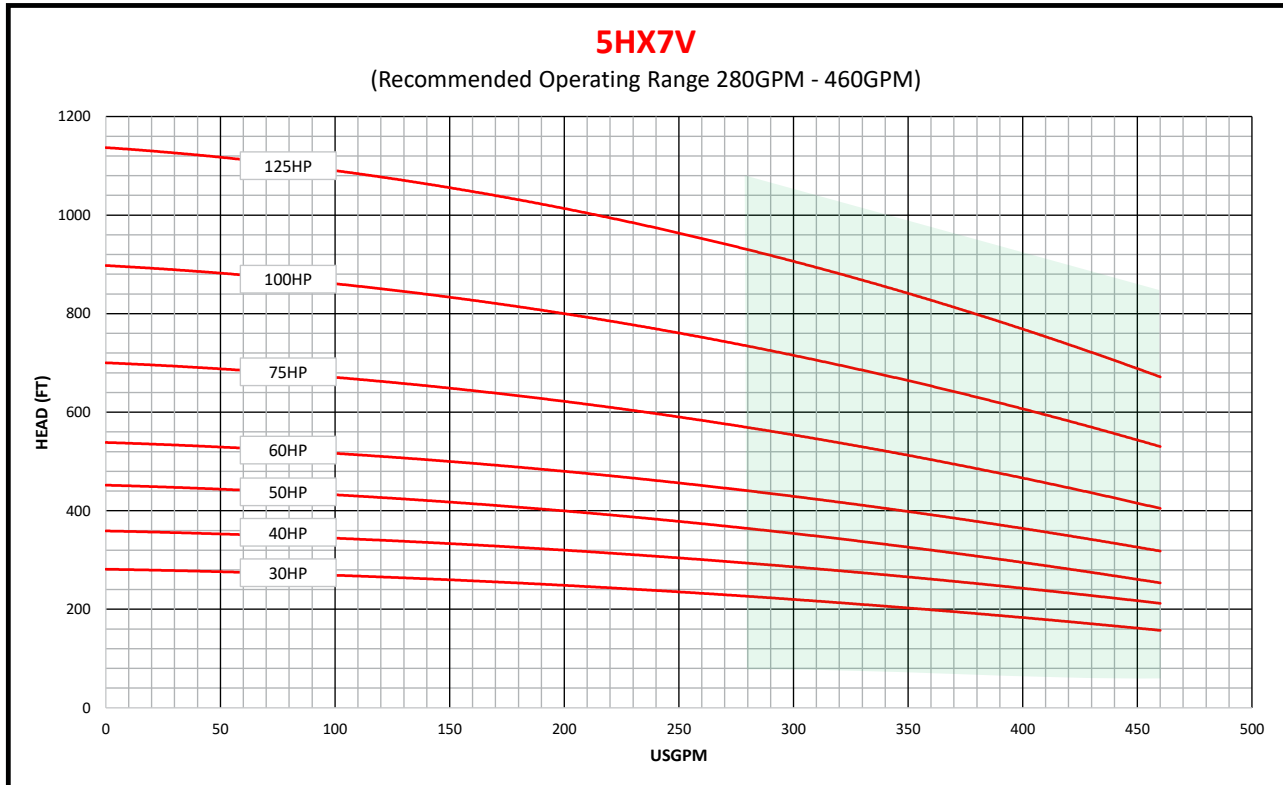

280 GPM		Wolf Item No	Recommended Operating Range 280GPM - 460GPM								460 GPM		
Model	Total Stages		A Trim Stages	B Trim Stages	C Trim Stages	HP	Head @ 280 GPM	Head @ 320 GPM	Head @ 400 GPM	Head @ 460 GPM	360 GPM (BEP)	NOL HP	Shutoff Head
5HX7V	1	WS5HX7V1-007-360	1	0		7.5	48	46	42	34	45	6.6	60
	2	WS5HX7V1-010-360	0	2		10	78	74	63	50	70	11.0	102
	2	WS5HX7V1-015-360	2	0		15	95	92	84	68	90	13.3	120
	3	WS5HX7V2-015-360	0	3		15	117	111	95	75	105	16.5	153
	3	WS5HX7V1-020-360	3	0		20	143	138	126	102	135	19.9	180
	4	WS5HX7V1-025-360	3	1		25	182	175	158	127	170	25.4	231
	5	WS5HX7V1-030-360	3	2		30	221	212	189	152	205	30.9	282
	6	WS5HX7V1-040-360	6	0		40	285	276	252	204	270	39.8	360
	8	WS5HX7V1-050-360	5	3		50	355	341	305	245	330	49.7	453
	9	WS5HX7V1-060-360	9	0		60	428	414	378	306	405	59.7	540
A TRIM = 4.515" B TRIM = 4.25"	12	WS5HX7V1-075-360	10	2		75	553	534	483	390	520	77.3	702
	15	WS5HX7V1-100-360	15	0		100	713	690	630	510	675	99.5	900
	19	WS5HX7V1-125-360	19	0		125	903	874	798	646	855	126.0	1140
P.E.I. - .87													
Total Stages	HP	Weight (lbs)	Length (inches)	Standard Materials of Construction		Available Discharge Sizes (NPT)		Upgraded Bushing Material Options		Upgraded Shaft Material Options			
5	30	130	46.1	Motor bracket	Ductile Iron	3", 4" (specify with order)		Vesconite		316SS, Chrome, Ion			
6	40	150	52.85	Int. Bowl	Cast Iron (lined)								
8	50	190	66.35	Discharge	Ductile Iron								
9	60	210	73.1	Impeller	Bronze								
12	75	270	93.35	Bushing	Bronze or rubber								
15	100	330	113.6	Collet	Stainless Steel								
19	125	410	140.6	Fasteners	Stainless Steel								
				Shaft	416SS								
				Sand Collar	Bronze								

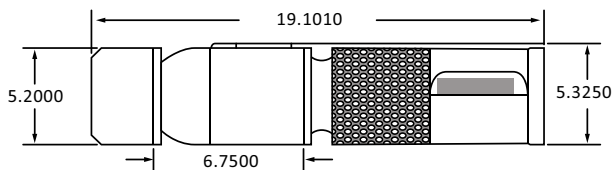

Important Note(s):
 Charted performance is based upon 3450rpm, and is guaranteed to ANSI/HI 14.6 acceptance grade 2B within the preferred operating range window indicated on the curve above.

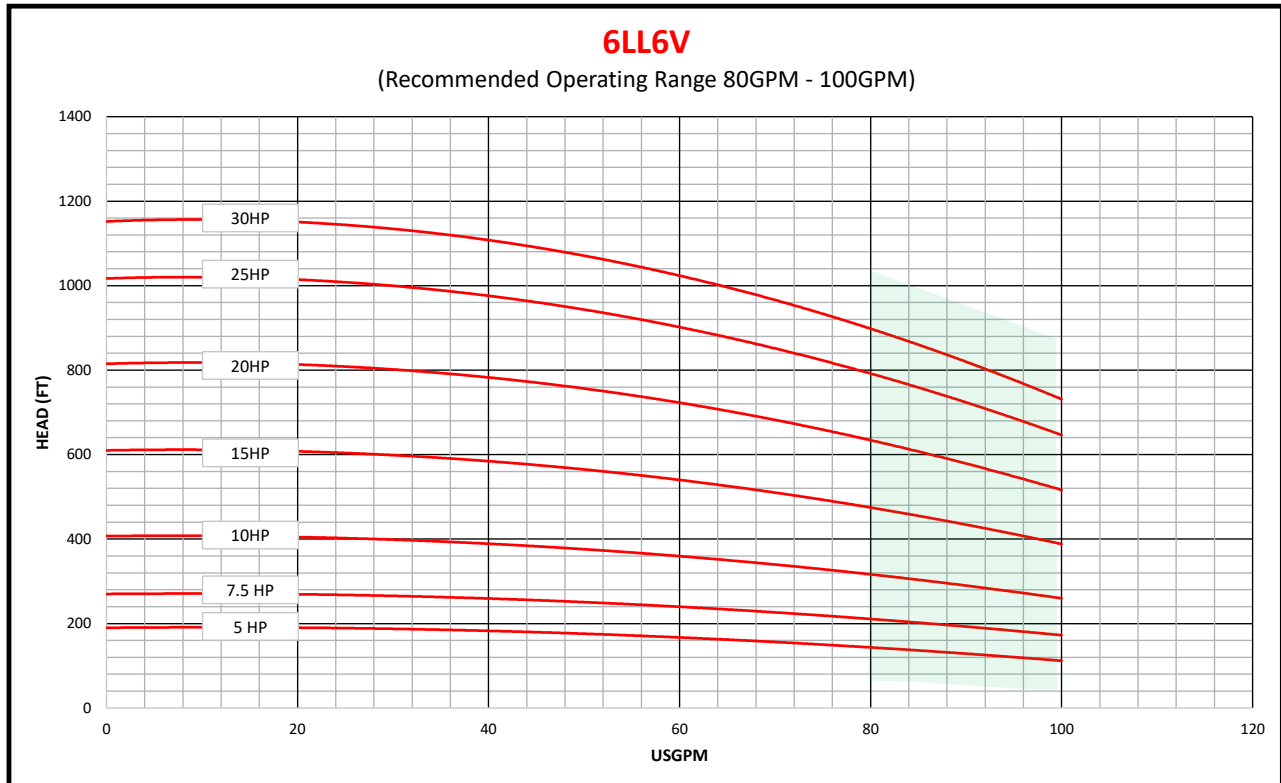

80 GPM		Wolf Item No	Recommended Operating Range 80GPM - 100GPM							100 GPM			
Model	Total Stages		A Trim Stages	B Trim Stages	C Trim Stages	HP	Head @ 80 GPM	Head @ 85 GPM	Head @ 95 GPM	Head @ 100 GPM	Head @ 90 GPM (BEP)	NOL HP	Shutoff Head
6LL6V A Trim = 4.515" B Trim = 4.250" P.E.I - .93	3	WS6LL6V1-005-90	2	1		5	144	135	120	112	130	5.0	190
	4	WS6LL6V1-007-90	4	0		7.5	211	202	184	172	192	7.1	270
	6	WS6LL6V1-010-90	6	0		10	317	304	276	260	288	10.2	407
	9	WS6LL6V1-015-90	9	0		15	475	455	415	387	432	15.3	610
	12	WS6LL6V1-020-90	12	0		20	635	608	551	516	575	20.4	815
	15	WS6LL6V1-025-90	15	0		25	792	760	690	645	720	25.6	1017
	17	WS6LL6V1-030-90	17	0		30	900	860	780	731	815	29.0	1152

Total Stages	HP	Weight (lbs)	Length (inches)	Standard Materials of Construction		Available Discharge Sizes (NPT)	Upgraded Bushing Material Options	Upgraded Shaft Material Options
3	5	81	26.91	Motor bracket	Ductile Iron	3", 4" (specify with order)	Vesconite	316SS, Chrome, Ion
4	7.5	97	31.79	Int. Bowl	Cast Iron (lined)			
6	10	129	41.55	Discharge	Ductile Iron			
9	15	177	56.19	Impeller	Bronze			
12	20	225	70.83	Bushing	Bronze or rubber			
15	25	273	85.47	Collet	Stainless Steel			
17	30	305	95.23	Fasteners	Stainless Steel			
				Shaft	416SS			
				Sand Collar	Bronze			

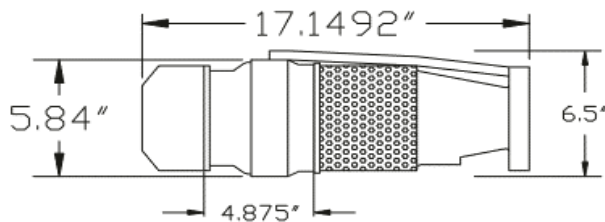

Important Note(s):
Charted performance is based upon 3450rpm, and is guaranteed to ANSI/HI 14.6 acceptance grade 2B within the preferred operating range window indicated on the curve above.

110 - 160 GPM

8" Well

5- 50 HP

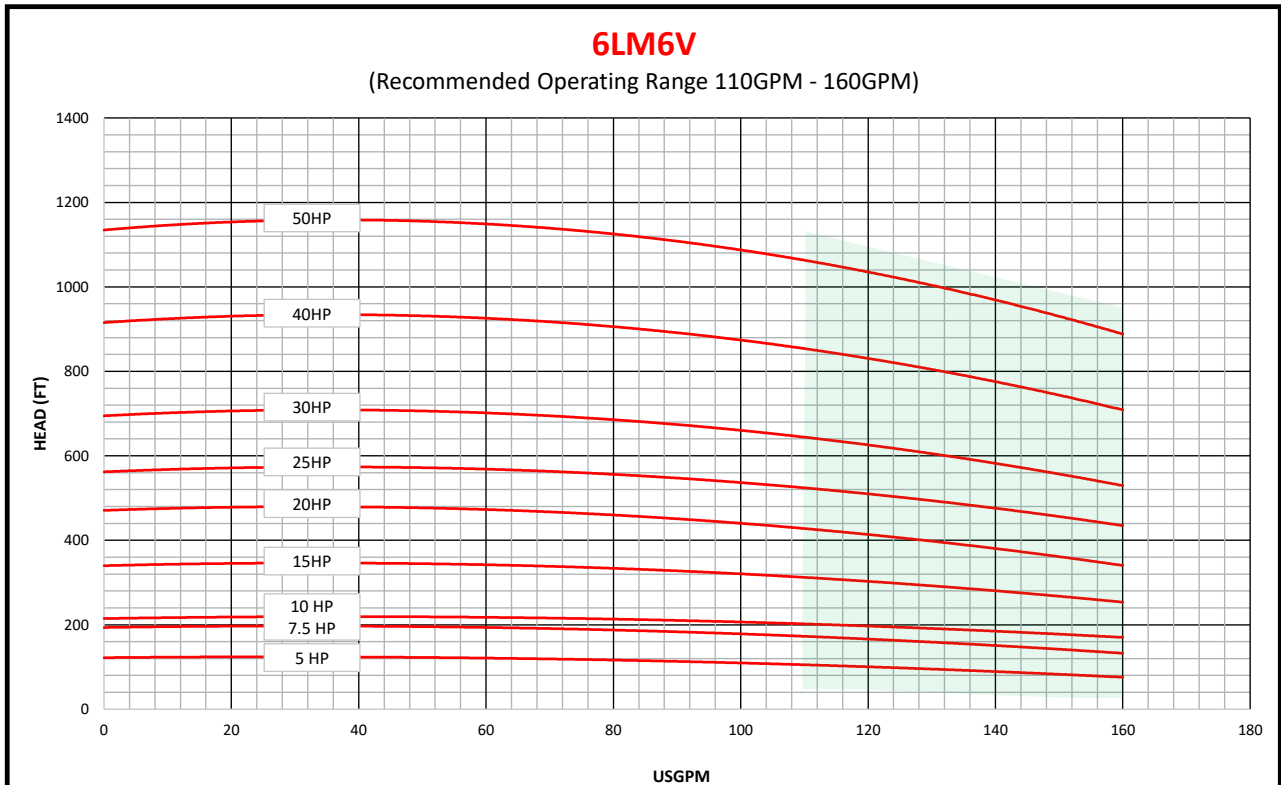

110 GPM		Wolf Item No	Recommended Operating Range 110GPM - 160GPM								160 GPM			
Model	Total Stages		A Trim Stages	B Trim Stages	C Trim Stages	HP	Head @ 110 GPM	Head @ 125 GPM	Head @ 145 GPM	Head @ 160 GPM	Head @ 150 GPM (BEP)	NOL HP	Shutoff Head	
6LM6V	2	WS6LM6V1-005-150	0	2	0	5	106	98	86	76	82	4.7	122	
	3	WS6LM6V1-007-150	1	2	0	7.5	173	163	147	132	142	7.9	194	
	3	WS6LM6V1-010-150	3	0	0	10	201	195	182	168	180	9.6	215	
	5	WS6LM6V1-015-150	4	0	1	15	310	300	275	250	270	14.5	340	
	7	WS6LM6V1-020-150	5	0	2	20	425	409	371	336	366	20.0	471	
	8	WS6LM6V1-025-150	7	1	0	25	522	504	467	430	461	24.8	562	
	10	WS6LM6V1-030-150	8	2	0	30	642	618	570	524	562	30.3	695	
A Trim = 4.4375" B Trim = 4.25" C Trim = 4.0625"		13	WS6LM6V1-040-150	12	0	1	40	849	822	760	700	753	40.5	916
P.E.I - .88		16	WS6LM6V1-050-150	15	1	0	50	1058	1024	950.5	878	941	50.5	1135
Total Stages	HP	Weight (lbs)	Length (inches)	Standard Materials of Construction		Available Discharge Sizes (NPT)		Upgraded Bushing Material Options		Upgraded Shaft Material Options				
2	5	65	22.03	Motor bracket	Ductile Iron	3", 4" (specify with order)		Vesconite		316SS, Chrome, Ion				
3	7.5	81	26.91	Int. Bowl	Cast Iron (lined)									
3	10	81	26.91	Discharge	Ductile Iron									
5	15	113	36.67	Impeller	Stainless Steel									
7	20	145	46.43	Bushing	Bronze or rubber									
8	25	161	51.31	Collet	Stainless Steel									
10	30	193	61.07	Fasteners	Stainless Steel									
13	40	241	75.71	Shaft	416SS									
16	50	289	90.35	Sand Collar	Bronze									

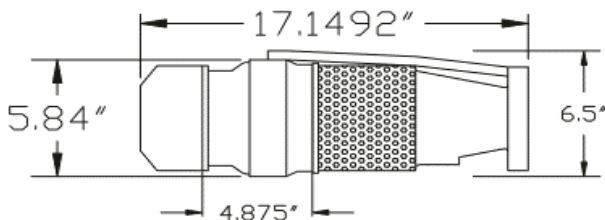

Important Note(s):
 Charted performance is based upon 3450rpm, and is guaranteed to ANSI/HI 14.6 acceptance grade 2B within the preferred operating range window indicated on the curve above.

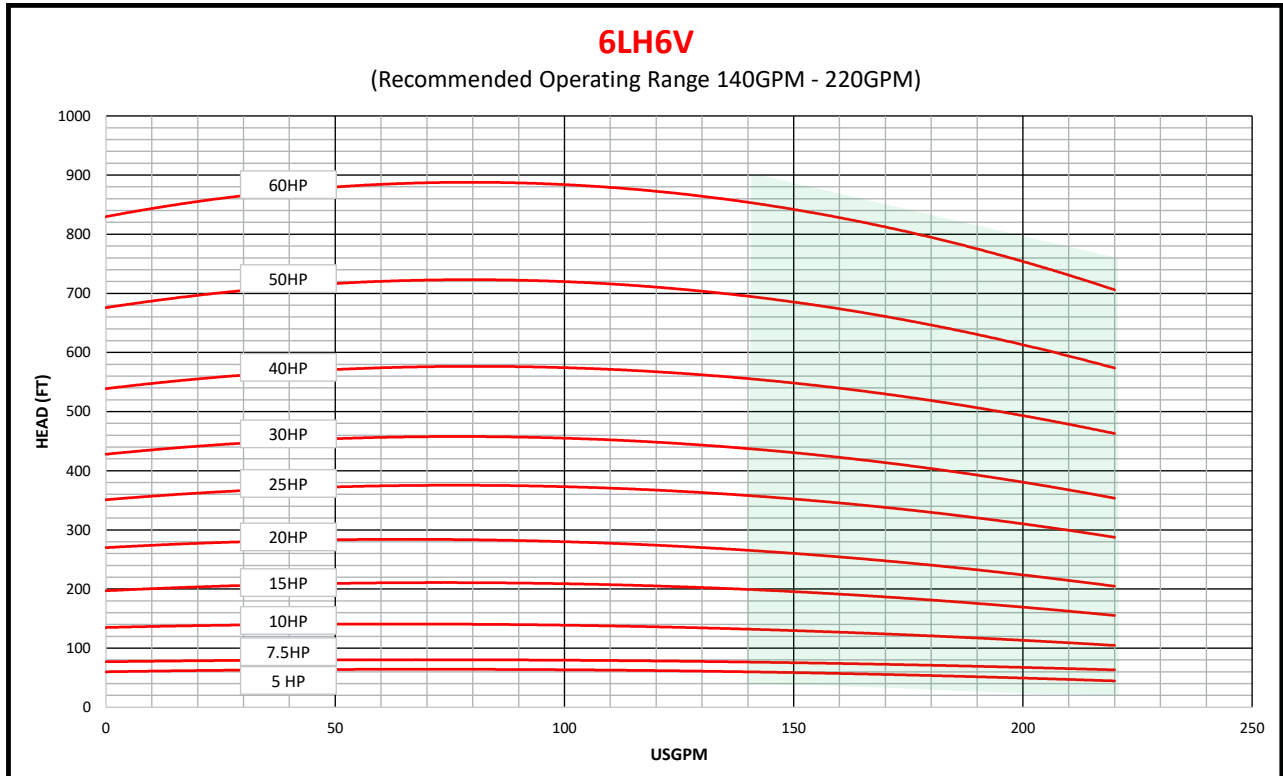

140 GPM		Wolf Item No	Recommended Operating Range 140GPM - 220GPM							220 GPM			
Model	Total Stages		A Trim Stages	B Trim Stages	C Trim Stages	HP	Head @ 140 GPM	Head @ 170 GPM	Head @ 200 GPM	Head @ 220 GPM	Head @ 189 GPM (BEP)	NOL HP	Shutoff Head
6LH6V	1	WS6LH6V1-005-190	0	1		5	60	56	49	45	51	4.1	60
	1	WS6LH6V1-007-190	1	0		7.5	76	73	67	63	70	5.8	77
	2	WS6LH6V1-010-190	1	1		10	131	125	113	104	118	9.9	135
	3	WS6LH6V1-015-190	1	2		15	199	188	168	156	175	14.0	197
	4	WS6LH6V1-020-190	1	3		20	265	248	225	204	232	18.1	270
	5	WS6LH6V1-025-190	3	2		25	357	340	308	288	321	25.5	351
	6	WS6LH6V1-030-190	4	2		30	436	416	378	354	394	31.2	428
	7	WS6LH6V1-040-190	7	0		40	553	532	490	462	511	40.3	539
	9	WS6LH6V1-050-190	8	1		50	692	664	609	573	635	50.1	676
	11	WS6LH6V1-060-190	10	1		60	850	816	749	705	781	61.6	830

Total Stages	HP	Weight (lbs)	Length (inches)	Standard Materials of Construction		Available Discharge Sizes (NPT)	Upgraded Bushing Material Options	Upgraded Shaft Material Options
1	5	48.8	17.15	Motor bracket	Ductile Iron	3", 4" (specify with order)	Vesconite	316SS, Chrome, Ion
1	7.5	48.8	17.15	Int. Bowl	Cast Iron (lined)			
2	10	64.6	22.03	Discharge	Ductile Iron			
3	15	80.4	26.91	Impeller	Stainless Steel			
4	20	96.2	31.79	Bushing	Bronze or rubber			
5	25	112	36.67	Collet	Stainless Steel			
6	30	127.8	41.55	Fasteners	Stainless Steel			
7	40	143.6	46.43	Shaft	416SS			
9	50	175.2	56.19	Sand Collar	Bronze			
11	60	206.8	65.95					

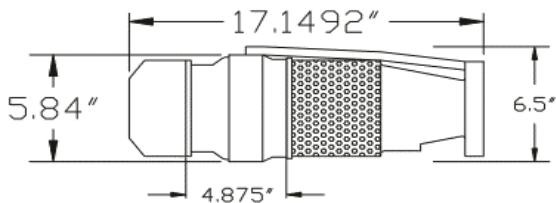

Important Note(s):

Charted performance is based upon 3450rpm, and is guaranteed to ANSI/HI 14.6 acceptance grade 2B within the preferred operating range window indicated on the curve above.

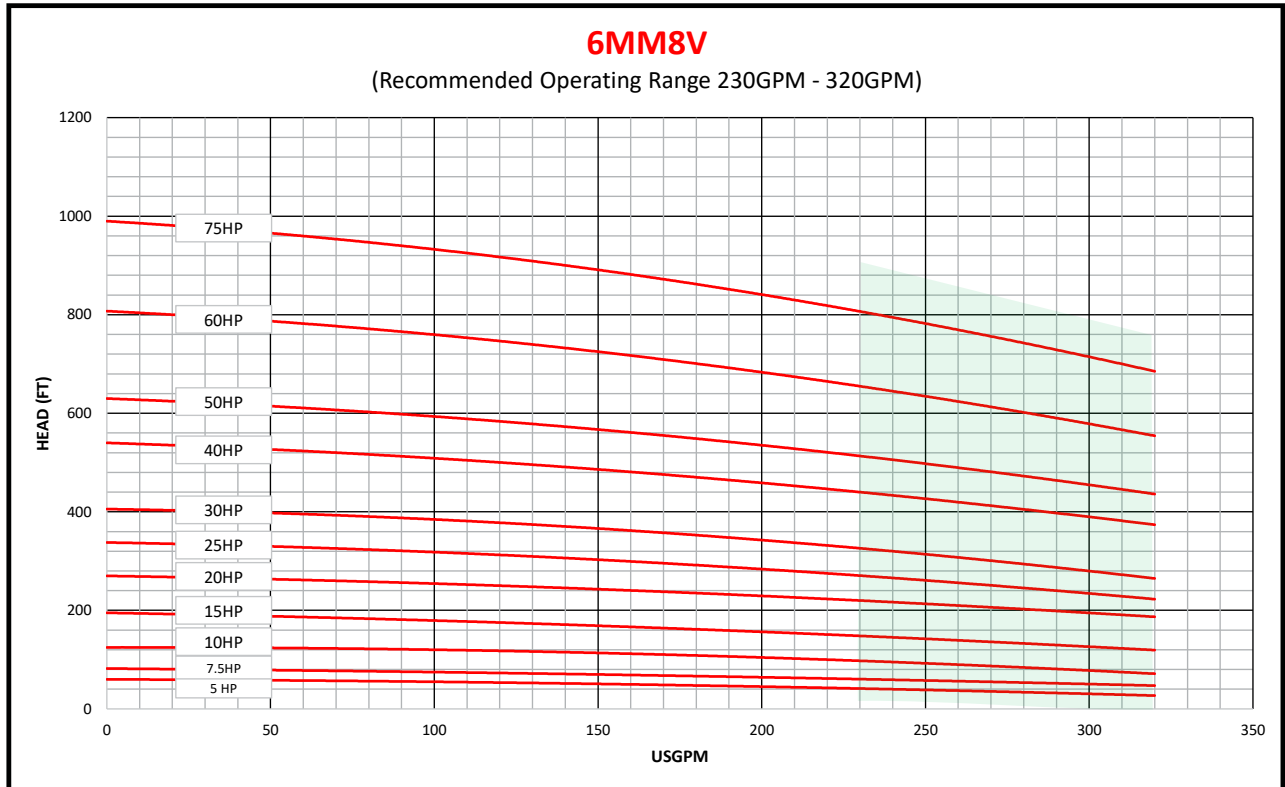

8" Well

230 GPM		Wolf Item No	Recommended Operating Range 230GPM - 320GPM								320 GPM		
Model	Total Stages		A Trim Stages	B Trim Stages	C Trim Stages	HP	Head @ 230 GPM	Head @ 260 GPM	Head @ 280 GPM	Head @ 320 GPM	Head @ 300 GPM (BEP)	NOL HP	Shutoff Head
6MM8V	1	WS6MM8V1-005-300	0	0	1	5	41	37	35	27	30	5.0	60
	1	WS6MM8V1-007-300	1	0	0	7.5	58	55	54	50	53	7.0	82
	2	WS6MM8V1-010-300	0	0	2	10	98	88	85	70	80	9.0	125
	3	WS6MM8V1-015-300	0	0	3	15	150	136	132	118	130	14.0	195
	3	WS6MM8V1-020-300	3	0	0	20	219	210	204	186	195	20.3	270
	4	WS6MM8V1-025-300	3	0	1	25	270	256	246	222	235	24.5	338
	5	WS6MM8V1-030-300	3	0	2	30	325	308	295	264	280	29.0	406
	6	WS6MM8V1-040-300	6	0	0	40	438	420	408	372	390	40.6	540
	7	WS6MM8V1-050-300	7	0	0	50	511	490	476	434	455	47.4	630
	9	WS6MM8V1-060-300	8	1	0	60	652	624	606	551	580	60.3	807
	P.E.I - .87	11	WS6MM8V1-075-300	11	0	0	75	803	770	748	682	715	74.5

Total Stages	HP	Weight (lbs)	Length (inches)	Standard Materials of Construction		Available Discharge Sizes (NPT)	Upgraded Bushing Material Options	Upgraded Shaft Material Options
1	5	56	17.25	Motor bracket	Ductile Iron	4"	Vesconite	316SS, Chrome, Ion
1	7.5	56	17.25	Int. Bowl	Cast Iron (lined)			
2	10	75	22.13	Discharge	Ductile Iron			
3	15	94	27	Impeller	Stainless Steel			
3	20	94	27	Bushing	Bronze or rubber			
4	25	113	31.88	Collet	Stainless Steel			
5	30	132	36.75	Fasteners	Stainless Steel			
6	40	151	41.63	Shaft	416SS			
7	50	170	46.5	Sand Collar	Bronze			
9	60	208	56.25					
11	75	246	66					

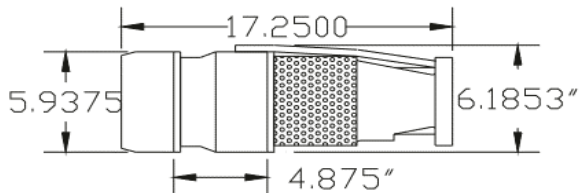

Important Note(s):

Charted performance is based upon 3450rpm, and is guaranteed to ANSI/HI 14.6 acceptance grade 2B within the preferred operating range window indicated on the curve above.

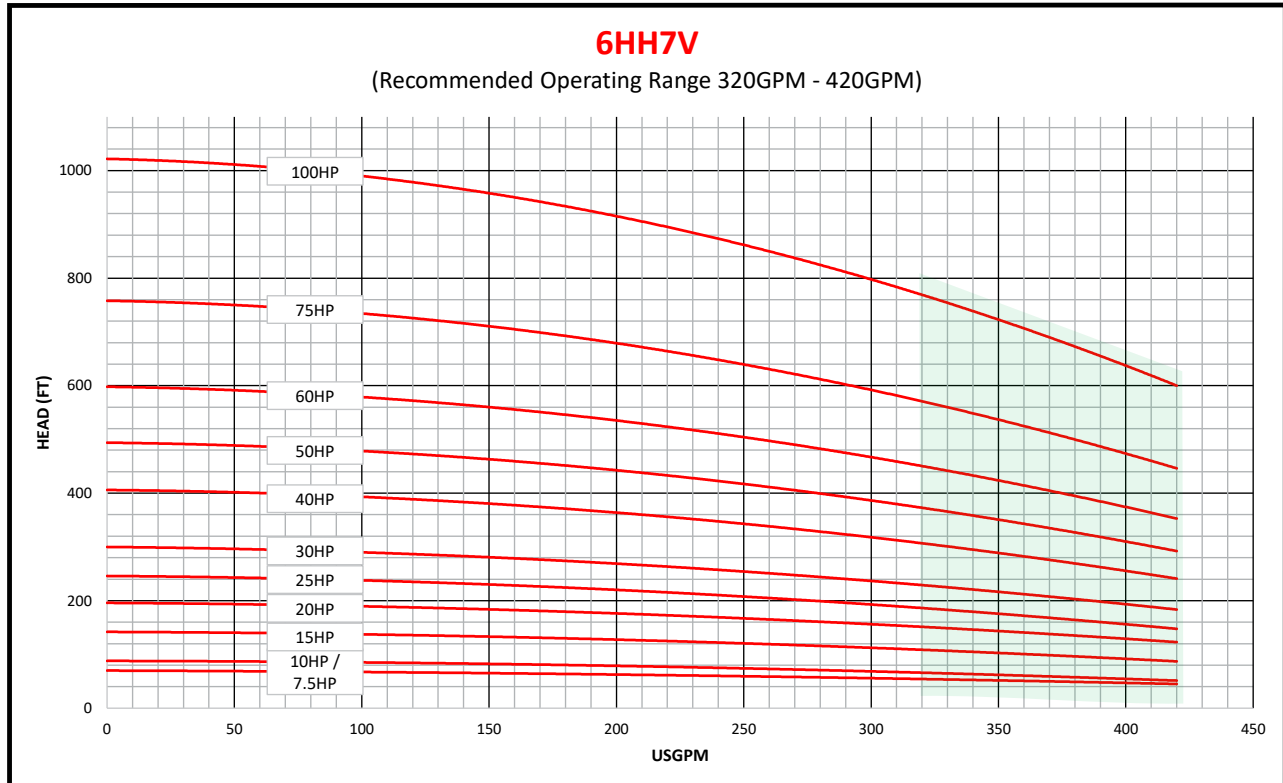

320GPM		Wolf Item No	Recommended Operating Range 320GPM - 420GPM								420GPM		
Model	Total Stages		A Trim Stages	B Trim Stages	C Trim Stages	HP	Head @ 320 GPM	Head @ 350 GPM	Head @ 400 GPM	Head @ 420 GPM	Head @ 370 GPM (BEP)	NOL HP	Shutoff Head
6HH7V A Trim = 4.515" B Trim = 4.25" C Trim = 4.0" P.E.I - .99	1	WS6HH7V1-007-370	0	1	0	7.5	54	52	47	45	50	7.2	70
	1	WS6HH7V1-010-370	1	0	0	10	66	62	55	51	59	8.9	88
	2	WS6HH7V1-015-370	1	0	1	15	108	103	93	86	99	14.5	142
	3	WS6HH7V1-020-370	1	0	2	20	150	144	131	121	139	20.2	196
	3	WS6HH7V1-025-370	2	1	0	25	186	176	157	147	168	25.0	246
	4	WS6HH7V1-030-370	2	1	1	30	228	217	195	182	208	30.7	300
	5	WS6HH7V1-040-370	4	0	1	40	306	289	258	239	276	41.2	406
	6	WS6HH7V1-050-370	5	0	1	50	372	351	313	290	335	50.1	494
	7	WS6HH7V1-060-370	6	1	0	60	450	424	377	351	404	60.6	598
	9	WS6HH7V1-075-370	8	0	1	75	570	537	478	443	512	76.8	758
	12	WS6HH7V1-100-370	11	0	1	100	768	723	643	596	689	103.5	1022

Total Stages	HP	Weight (lbs)	Length (inches)	Standard Materials of Construction		Available Discharge Sizes (NPT)	Upgraded Bushing Material Options	Upgraded Shaft Material Options
1	7.5	47	17.21	Motor bracket	Ductile Iron	3", 4" (specify with order)	Vesconite	316SS, Chrome, Ion
1	10	47	17.21	Int. Bowl	Cast Iron (lined)			
2	15	62	22.1	Discharge	Ductile Iron			
3	20	77	27	Impeller	Stainless Steel			
3	25	77	27	Bushing	Bronze or rubber			
4	30	92	31.85	Collet	Stainless Steel			
5	40	107	36.75	Fasteners	Stainless Steel			
6	50	122	41.62	Shaft	416SS			
7	60	137	46.5	Sand Collar	Bronze			
9	75	167	56.25					
12	100	212	70.88					

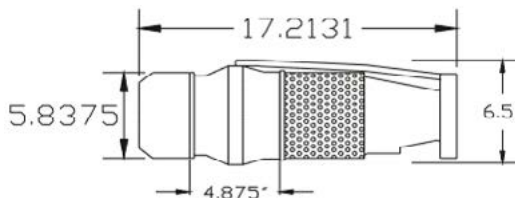

Important Note(s):
 Charted performance is based upon 3450rpm, and is guaranteed to ANSI/HI 14.6 acceptance grade 2B within the preferred operating range window indicated on the curve above.

8" Well

440 - 540 GPM 7.5 - 30 HP

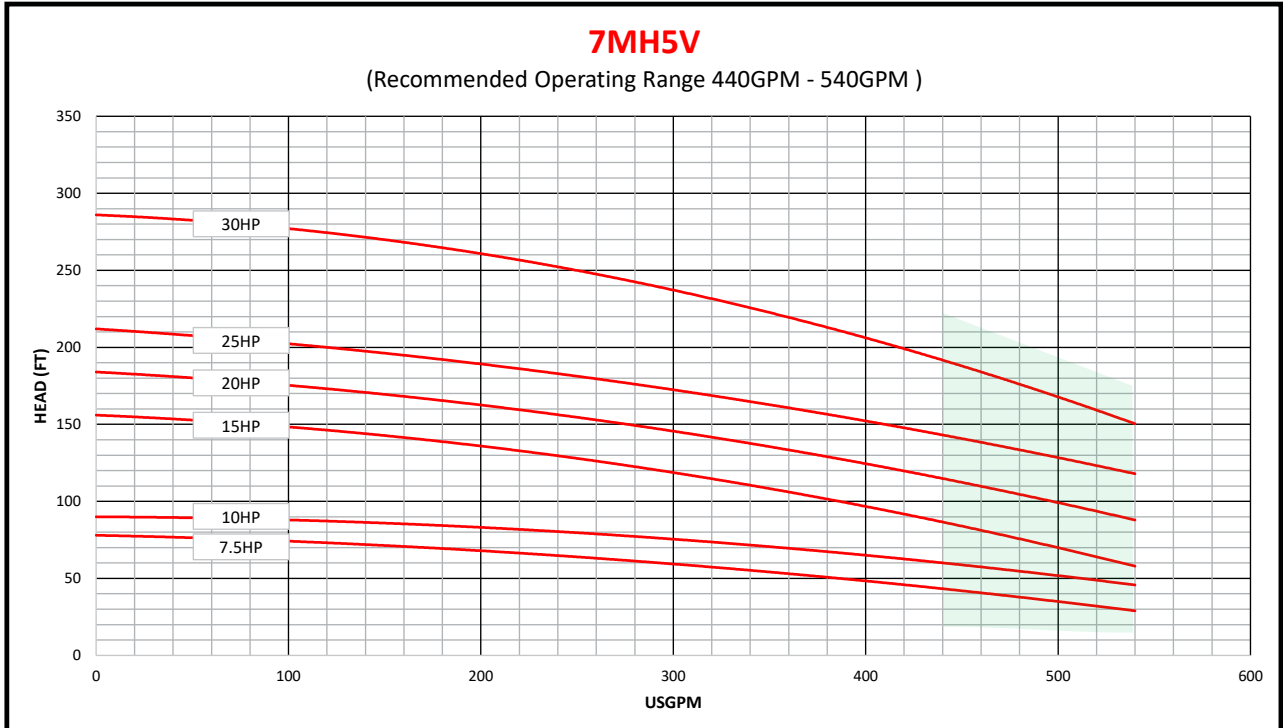

8" Well

440GPM		Wolf Item No	Recommended Operating Range 440GPM - 540GPM								540GPM		
Model	Total Stages		A Trim Stages	B Trim Stages	C Trim Stages	HP	Head @ 440 GPM	Head @ 475 GPM	Head @ 525 GPM	Head @ 540 GPM	Head @ 504 GPM (BEP)	NOL HP	Shutoff Head
7MH5V A Trim = 5.5" B Trim = 5.31" C Trim = 5.0625"	1	WS7MH5V1-007-500	0	0	1	7.5	43	39	31	29	35	7.2	78
	1	WS7MH5V1-010-500	0	1	0	10	60	56	48	46	51	9.3	90
	2	WS7MH5V1-015-500	0	0	2	15	86	78	62	58	70	14.4	156
	2	WS7MH5V1-020-500	1	0	1	20	114	107	93	87	99	19.1	184
	2	WS7MH5V1-025-500	2	0	0	25	142	136	124	116	128	23.8	212
	3	WS7MH5V1-030-500	1	2	0	30	191	180	158	150	166	30.6	286
	4	WS7MH5V1-040-500	2	0	2	40	228	214	186	174	198	38.2	368
	5	WS7MH5V1-050-500	3	0	2	50	299	282	248	232	262	50.1	474
	5	WS7MH5V1-060-500	5	0	0	60	355	340	310	290	320	59.5	530
7	WS7MH5V1-075-500	5	0	2	75	441	418	372	348	390	73.9	686	
9	WS7MH5V1-100-500	7	0	2	100	583	554	496	464	518	97.7	898	

Total Stages	HP	Weight (lbs)	Length (inches)	Standard Materials of Construction		Available Discharge Sizes (NPT)	Upgraded Bushing Material Options	Upgraded Shaft Material Options
1	7.5	100	24.75	Motor bracket	Ductile Iron	5", 6" (specify with order)	Vesconite	316SS, Chrome, Ion
1	10	100	24.75	Int. Bowl	Cast Iron (lined)			
2	15	134	31.75	Discharge	Ductile Iron			
2	20	134	31.75	Impeller	Stainless Steel			
2	25	134	31.75	Bushing	Bronze or rubber			
3	30	168	38.75	Collet	Stainless Steel			
				Fasteners	Stainless Steel			
				Shaft	416SS			
				Sand Collar	Bronze			

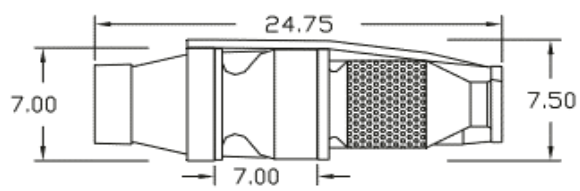

Important Note(s):
 Charted performance is based upon 3450rpm, and is guaranteed to ANSI/HI 14.6 acceptance grade 2B within the preferred operating range window indicated on the curve above.

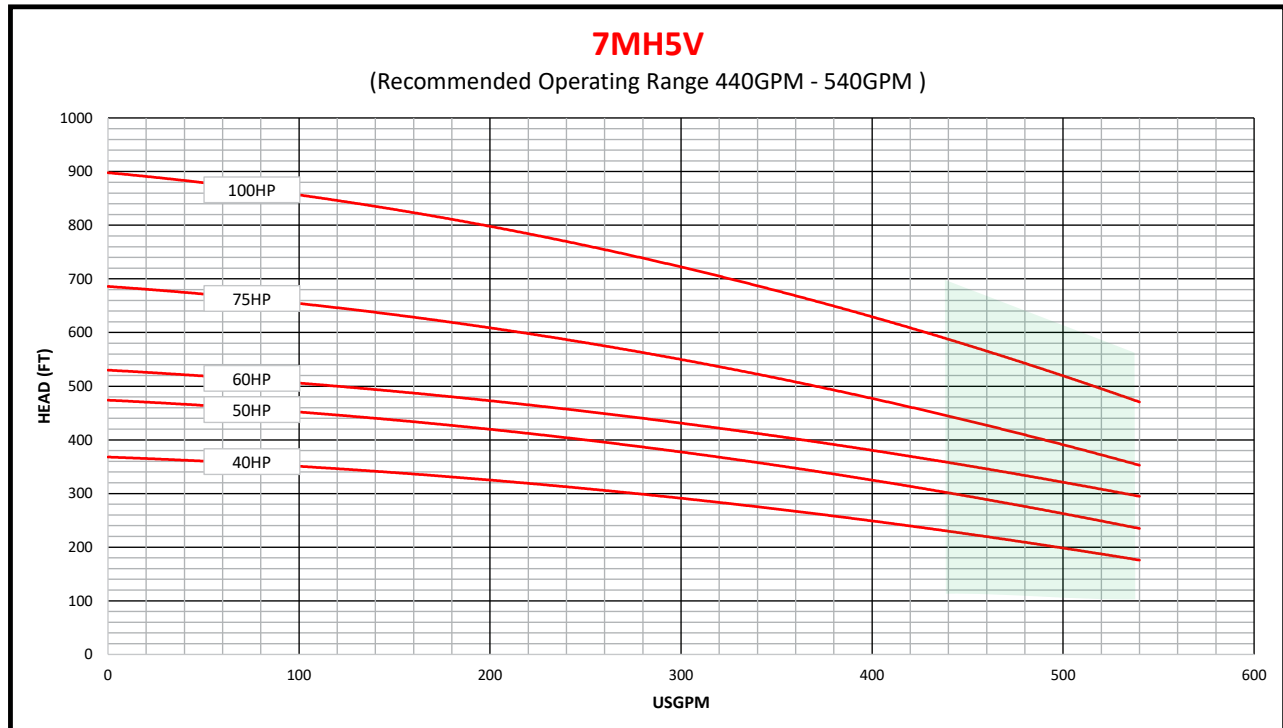

440GPM		Wolf Item No	Recommended Operating Range 440GPM - 540GPM								540GPM		
Model	Total Stages		A Trim Stages	B Trim Stages	C Trim Stages	HP	Head @ 440 GPM	Head @ 475 GPM	Head @ 525 GPM	Head @ 540 GPM	Head @ 504 GPM (BEP)	NOL HP	Shutoff Head
7MH5V A Trim = 5.5" B Trim = 5.31" C Trim = 5.0625"	1	WS7MH5V1-007-500	0	0	1	7.5	43	39	31	29	35	7.2	78
	1	WS7MH5V1-010-500	0	1	0	10	60	56	48	46	51	9.3	90
	2	WS7MH5V1-015-500	0	0	2	15	86	78	62	58	70	14.4	156
	2	WS7MH5V1-020-500	1	0	1	20	114	107	93	87	99	19.1	184
	2	WS7MH5V1-025-500	2	0	0	25	142	136	124	116	128	23.8	212
	3	WS7MH5V1-030-500	1	2	0	30	191	180	158	150	166	30.6	286
	4	WS7MH5V1-040-500	2	0	2	40	228	214	186	174	198	38.2	368
	5	WS7MH5V1-050-500	3	0	2	50	299	282	248	232	262	50.1	474
	5	WS7MH5V1-060-500	5	0	0	60	355	340	310	290	320	59.5	530
7	WS7MH5V1-075-500	5	0	2	75	441	418	372	348	390	73.9	686	
9	WS7MH5V1-100-500	7	0	2	100	583	554	496	464	518	97.7	898	

Total Stages	HP	Weight (lbs)	Length (inches)	Standard Materials of Construction		Available Discharge Sizes (NPT)	Upgraded Bushing Material Options	Upgraded Shaft Material Options
4	40	202	45.75	Motor bracket	Ductile Iron	5", 6" (specify with order)	Vesconite	316SS, Chrome, Ion
5	50	236	52.75	Int. Bowl	Cast Iron (lined)			
5	60	236	52.75	Discharge	Ductile Iron			
7	75	304	66.75	Impeller	Stainless Steel			
9	100	372	80.75	Bushing	Bronze or rubber			
				Collet	Stainless Steel			
				Fasteners	Stainless Steel			
				Shaft	416SS			
				Sand Collar	Bronze			

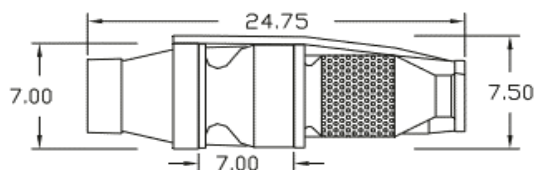

Important Note(s):

Charted performance is based upon 3450rpm, and is guaranteed to ANSI/HI 14.6 acceptance grade 2B within the preferred operating range window indicated on the curve above.

8" Well

560 - 740 GPM 15 - 30 HP

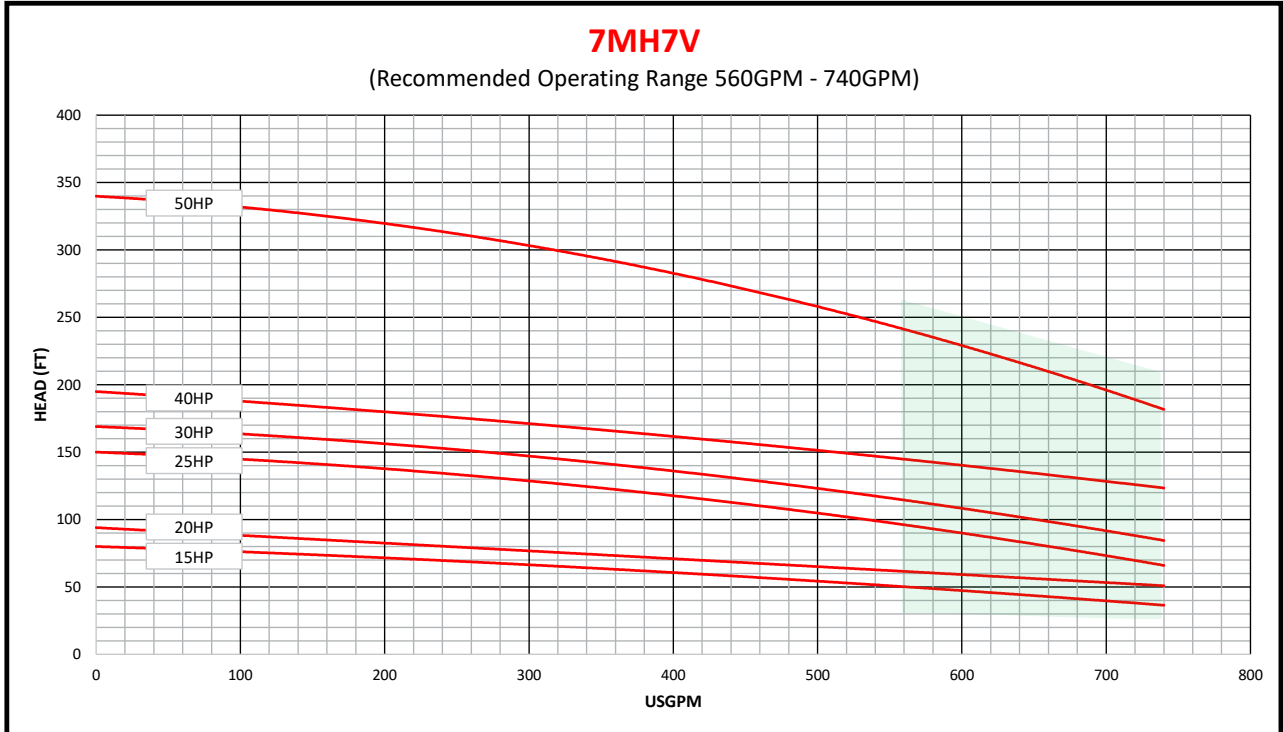

8" Well

560GPM		Wolf Item No	Recommended Operating Range 560GPM - 740GPM							740GPM			
Model	Total Stages		A Trim Stages	B Trim Stages	C Trim Stages	HP	Head @ 560 GPM	Head @ 600 GPM	Head @ 650 GPM	Head @ 740 GPM	Head @ 701 GPM (BEP)	NOL HP	Shutoff Head
7MH7V	1	WS7MH7V1-015-700	0	1	0	15	50	47	44	36	40	15.5	80
	1	WS7MH7V1-020-700	1	0	0	20	61	59	57	50	54	19.0	94
	2	WS7MH7V1-025-700	0	0	2	25	96	90	82	66	73	24.0	150
	2	WS7MH7V1-030-700	0	2	0	30	113	109	102	84	91	27.5	169
	2	WS7MH7V1-040-700	2	0	0	40	143	141	136	122	129	37.0	195
	4	WS7MH7V1-050-700	0	4	0	50	237	230	220	180	194	50.4	340
	4	WS7MH7V1-060-700	2	2	0	60	270	262	250	216	232	59.8	370
	5	WS7MH7V1-075-700	3	2	0	75	346	336	322	281	300	77.1	470
	6	WS7MH7V1-100-700	5	1	0	100	439	427	413	368	388	99.1	585
7	WS7MH7V1-125-700	7	0	0	125	532	518	504	455	476	121.0	700	
9	WS7MH7V1-150-700	8	1	0	150	667	649	629	563	592	151.0	885	

Total Stages	HP	Weight (lbs)	Length (inches)	Standard Materials of Construction		Available Discharge Sizes (NPT)	Upgraded Bushing Material Options	Upgraded Shaft Material Options
1	15	100	24.75	Motor bracket	Ductile Iron	5", 6" (specify with order)	Vesconite	316SS, Chrome, Ion
1	20	100	24.75	Int. Bowl	Cast Iron (lined)			
2	25	134	31.75	Discharge	Ductile Iron			
2	30	134	31.75	Impeller	Stainless Steel			
2	40	134	31.75	Bushing	Bronze or rubber			
4	50	202	45.75	Collet	Stainless Steel			
				Fasteners	Stainless Steel			
				Shaft	416SS			
				Sand Collar	Bronze			

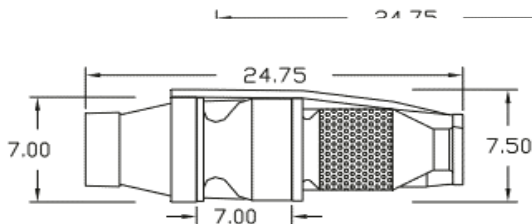

Important Note(s):

Charted performance is based upon 3450rpm, and is guaranteed to ANSI/HI 14.6 acceptance grade 2B within the preferred operating range window indicated on the curve above.

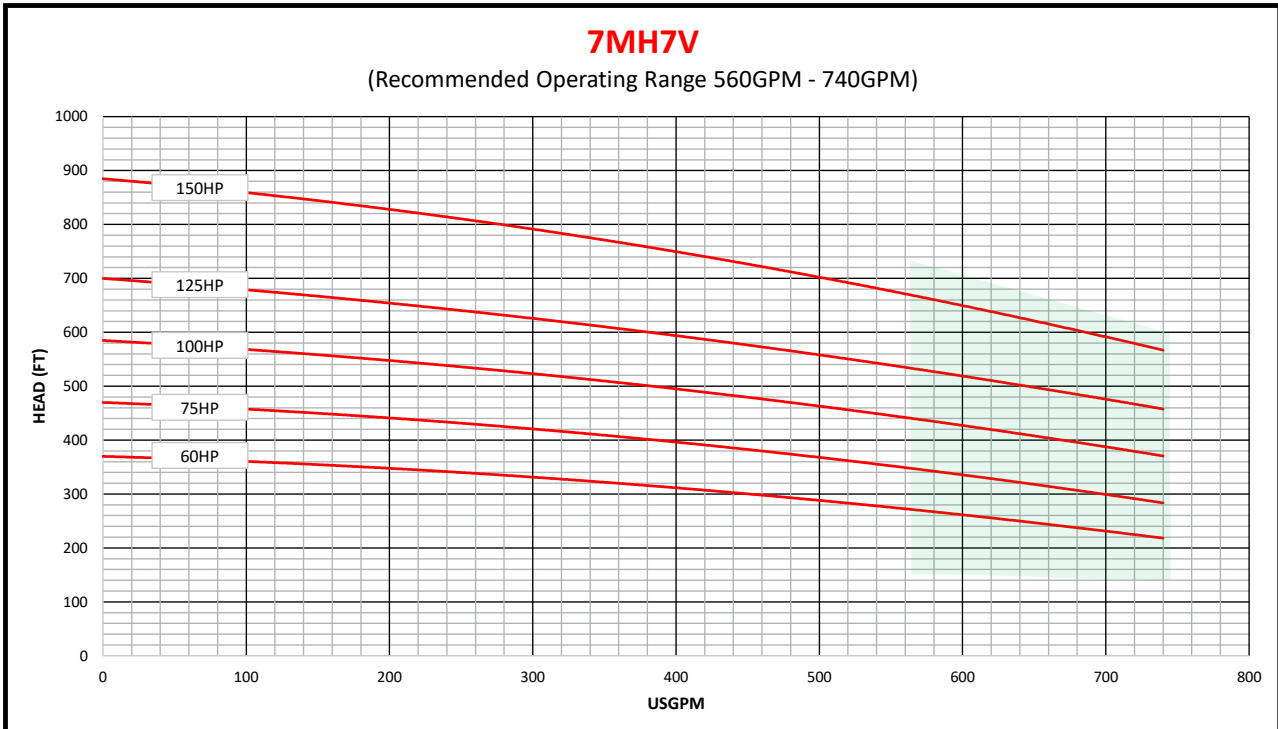

560GPM		Wolf Item No	Recommended Operating Range 560GPM - 740GPM								740GPM		
Model	Total Stages		A Trim Stages	B Trim Stages	C Trim Stages	HP	Head @ 560 GPM	Head @ 600 GPM	Head @ 650 GPM	Head @ 740 GPM	Head @ 701 GPM (BEP)	NOL HP	Shutoff Head
7MH7V	1	WS7MH7V1-015-700	0	1	0	15	50	47	44	36	40	15.5	80
	1	WS7MH7V1-020-700	1	0	0	20	61	59	57	50	54	19.0	94
	2	WS7MH7V1-025-700	0	0	2	25	96	90	82	66	73	24.0	150
	2	WS7MH7V1-030-700	0	2	0	30	113	109	102	84	91	27.5	169
	2	WS7MH7V1-040-700	2	0	0	40	143	141	136	122	129	37.0	195
	4	WS7MH7V1-050-700	0	4	0	50	237	230	220	180	194	50.4	340
	4	WS7MH7V1-060-700	2	2	0	60	270	262	250	216	232	59.8	370
	5	WS7MH7V1-075-700	3	2	0	75	346	336	322	281	300	77.1	470
	6	WS7MH7V1-100-700	5	1	0	100	439	427	413	368	388	99.1	585
7	WS7MH7V1-125-700	7	0	0	125	532	518	504	455	476	121.0	700	
9	WS7MH7V1-150-700	8	1	0	150	667	649	629	563	592	151.0	885	

Total Stages	HP	Weight (lbs)	Length (inches)	Standard Materials of Construction		Available Discharge Sizes (NPT)	Upgraded Bushing Material Options	Upgraded Shaft Material Options
4	60	202	45.75	Motor bracket	Ductile Iron	5", 6" (specify with order)	Vesconite	316SS, Chrome, Ion
5	75	236	52.75	Int. Bowl	Cast Iron (lined)			
6	100	270	59.75	Discharge	Ductile Iron			
7	125	304	66.75	Impeller	Stainless Steel			
9	150	372	80.75	Bushing	Bronze or rubber			
				Collet	Stainless Steel			
				Fasteners	Stainless Steel			
				Shaft	416SS			
				Sand Collar	Bronze			

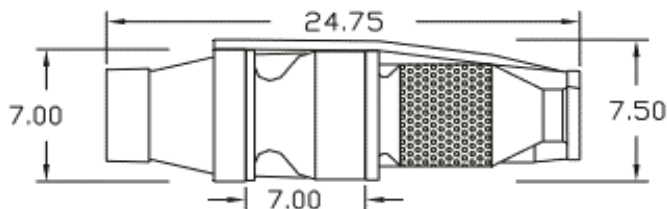

Important Note(s):
 Charted performance is based upon 3450rpm, and is guaranteed to ANSI/HI 14.6 acceptance grade 2B within the preferred operating range window indicated on the curve above.

320 - 480 GPM

10" Well

10 - 75 HP

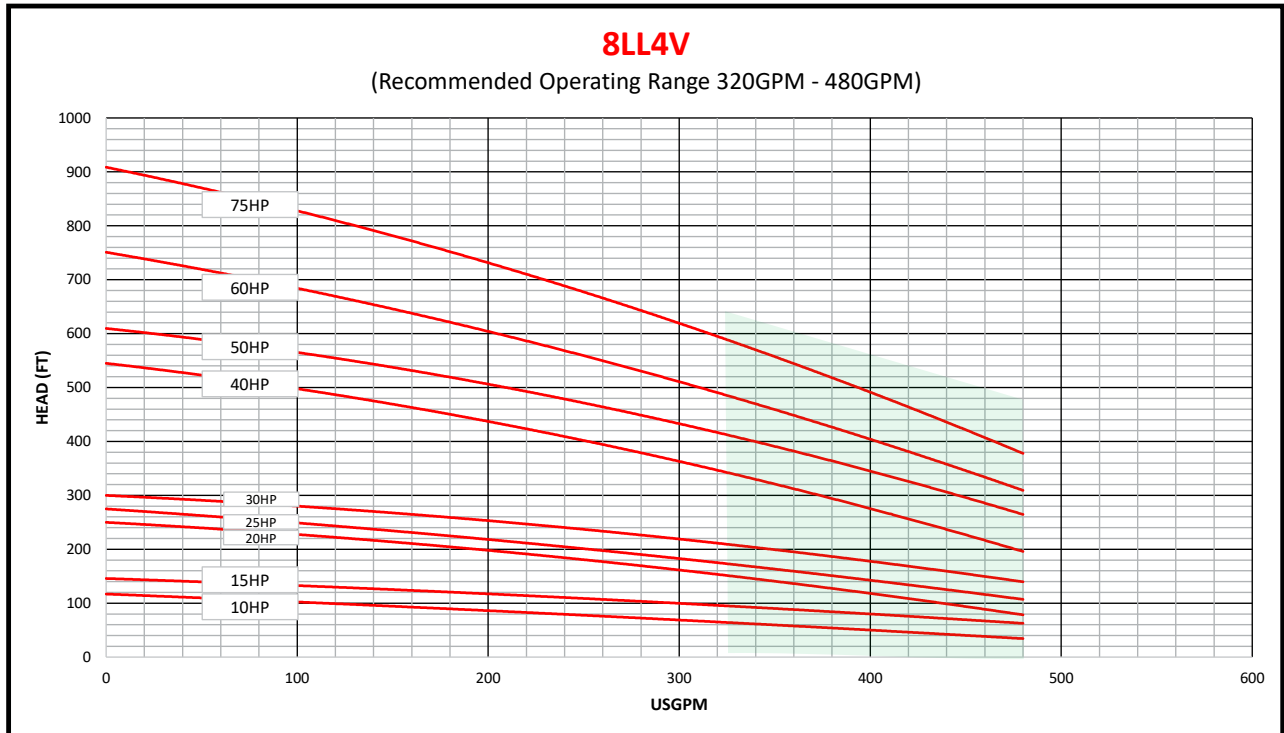

320 GPM		Wolf Item No	Recommended Operating Range 320GPM - 480GPM							480 GPM			
Model	Total Stages		A Trim Stages	B Trim Stages	C Trim Stages	HP	Head @ 320 GPM	Head @ 360 GPM	Head @ 440 GPM	Head @ 480 GPM	Head @ 400 GPM (BEP)	NOL HP	Shutoff Head
8LL4V	1	WS8LL4V1-010-400	0	0	1	10	65	58	na	na	50	9.7	117
	1	WS8LL4V1-015-400	1	0	0	15	94	88	72	61	83	14.6	146
	2	WS8LL4V1-020-400	0	1	1	20	153	135	100	77	120	20.0	250
	2	WS8LL4V1-025-400	1	1	0	25	174	158	127	105	145	25.3	275
	2	WS8LL4V1-030-400	2	0	0	30	209	197	161	138	178	29.2	300
	4	WS8LL4V1-040-400	0	4	0	40	346	310	236	195	280	40.0	545
	4	WS8LL4V1-050-400	3	1	0	50	410	385	309	260	350	51.0	610
	5	WS8LL4V1-060-400	4	0	1	60	476	445	365	295	428	63.5	752
6	WS8LL4V1-075-400	5	0	1	75	577	540	445	360	521	77.5	910	

Total Stages	HP	Weight (lbs)	Length (inches)	Standard Materials of Construction		Available Discharge Sizes (NPT)	Upgraded Bushing Material Options	Upgraded Shaft Material Options
1	10	101	26.25	Motor bracket	Ductile Iron	4", 6"	Vesconite	316SS, Chrome, Ion
1	15	101	26.25	Int. Bowl	Cast Iron (lined)			
2	20	135.5	32.88	Discharge	Ductile Iron			
2	25	135.5	32.88	Impeller	Bronze			
2	30	135.5	32.88	Bushing	Bronze or rubber			
4	40	204.5	46.13	Collet	Stainless Steel			
4	50	204.5	46.13	Fasteners	Stainless Steel			
5	60	239	52.75	Shaft	416SS			
6	75	273.5	59.38	Sand Collar	Bronze			

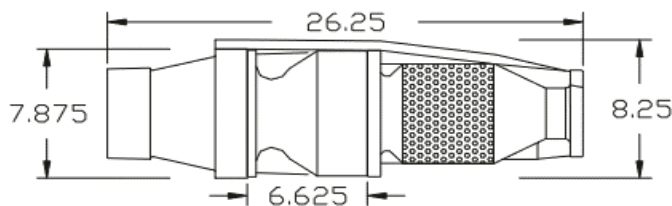

Important Note(s):
 Charted performance is based upon 3450rpm, and is guaranteed to ANSI/HI 14.6 acceptance grade 2B within the preferred operating range window indicated on the curve above.

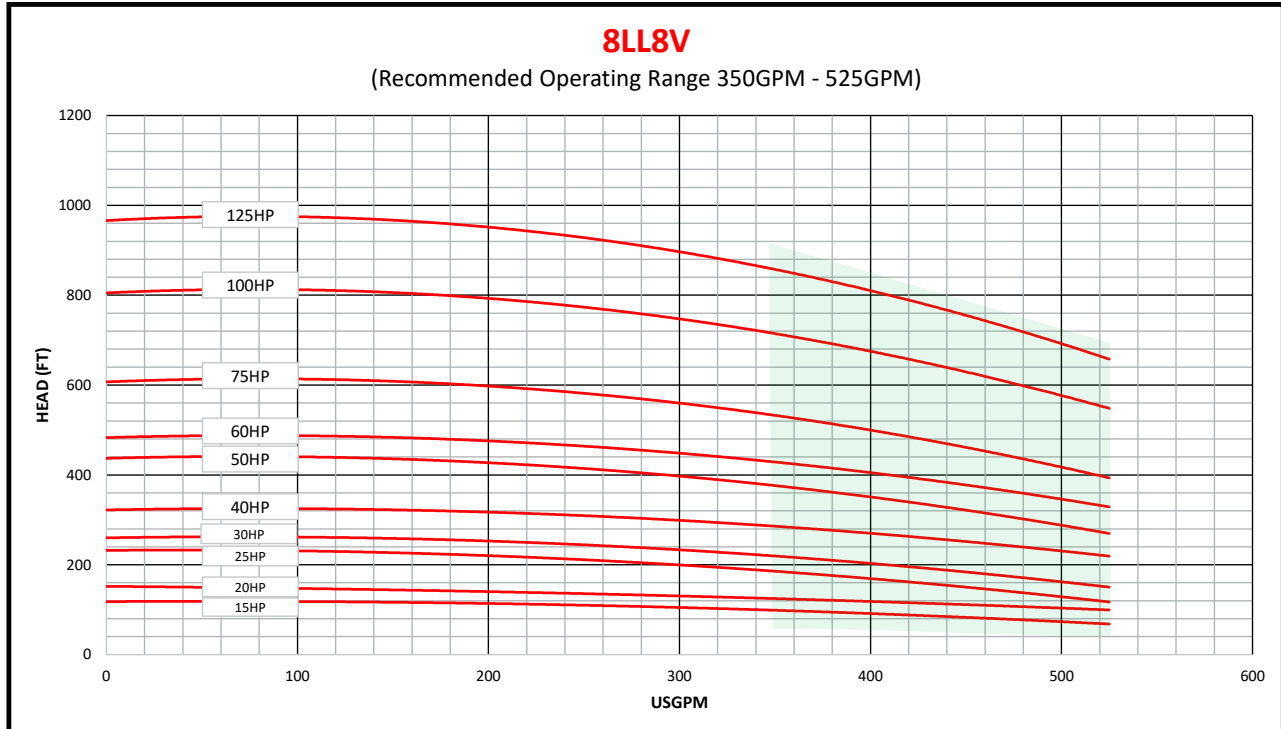

350 GPM		Wolf Item No	Recommended Operating Range 350GPM - 525GPM							525 GPM			
Model	Total Stages		A Trim Stages	B Trim Stages	C Trim Stages	HP	Head @ 350 GPM	Head @ 400 GPM	Head @ 475 GPM	Head @ 525 GPM	Head @ 425 GPM (BEP)	NOL HP	Shutoff Head
8LL8V	1	WS8LL8V1-015-425	0	1	0	15	98	92	78	68	88	15.0	118
	1	WS8LL8V1-020-425	1	0	0	20	124	119	108	99	115	21.5	152
	2	WS8LL8V1-025-425	0	0	2	25	185	170	140	117	160	25.4	232
	2	WS8LL8V1-030-425	0	2	0	30	218	205	173	150	194	30.0	260
	2	WS8LL8V1-040-425	2	0	0	40	286	270	240	220	262	41.6	322
	3	WS8LL8V1-050-425	1	2	0	50	375	353	304	270	337	50.6	437
A Trim = 6.45" B Trim = 5.937" C Trim = 5.687"	3	WS8LL8V1-060-425	3	0	0	60	429	405	360	330	393	64.0	483
	4	WS8LL8V1-075-425	3	0	1	75	532	500	438	394	483	75.1	607
	5	WS8LL8V1-100-425	5	0	0	100	715	675	600	550	655	104.0	805
	6	WS8LL8V1-125-425	6	0	0	125	858	810	720	660	786	124.8	966

Total Stages	HP	Weight (lbs)	Length (inches)	Standard Materials of Construction		Available Discharge Sizes (NPT)	Upgraded Bushing Material Options	Upgraded Shaft Material Options
1	15	100	26.25	Motor bracket	Ductile Iron	4", 6"	Vesconite	316SS, Chrome, Ion
1	20	100	26.25	Int. Bowl	Cast Iron (lined)			
2	25	134	32.88	Discharge	Ductile Iron			
2	30	134	32.88	Impeller	Stainless Steel			
2	40	134	32.88	Bushing	Bronze or rubber			
3	50	168	39.5	Collet	Stainless Steel			
3	60	168	39.5	Fasteners	Stainless Steel			
4	75	202	46.15	Shaft	416SS			
5	100	236	52.75	Sand Collar	Bronze			
6	125	270	59.5					

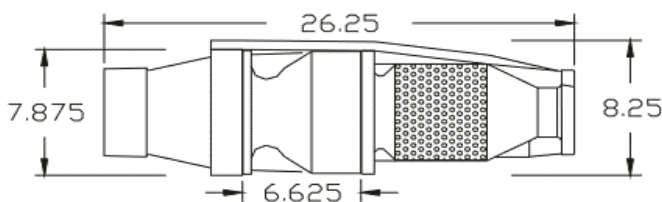

Important Note(s):

Charted performance is based upon 3450rpm, and is guaranteed to ANSI/HI 14.6 acceptance grade 2B within the preferred operating range window indicated on the curve above.

440 - 660 GPM

10" Well

15 - 125 HP

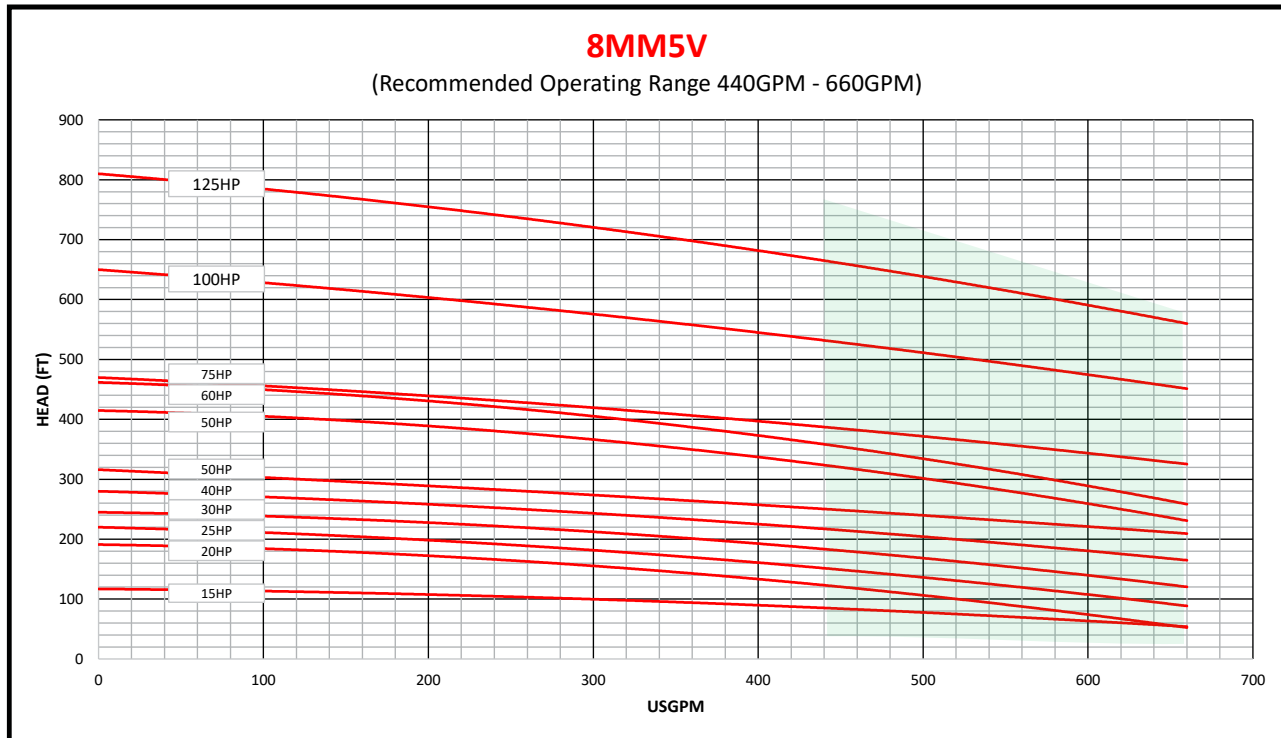

440 GPM		Wolf Item No	Recommended Operating Range 440GPM - 660GPM							660 GPM			
Model	Total Stages		A Trim Stages	B Trim Stages	C Trim Stages	HP	Head @ 440 GPM	Head @ 480 GPM	Head @ 640 GPM	Head @ 660 GPM	Head @ 560 GPM (BEP)	NOL HP	Shutoff Head
8MM5V	1	WS8MM5V1-015-560	0	1	0	15	85	80	58	53	70	15.9	117
	2	WS8MM5V1-020-560	0	0	2	20	122	115	60	53	85	20.0	191
	2	WS8MM5V1-025-560	0	1	1	25	150	143	94	89	120	25.0	220
	2	WS8MM5V1-030-560	0	2	0	30	182	175	127	120	152	30.0	245
	2	WS8MM5V1-040-560	1	1	0	40	216	210	171	164	190	38.5	280
	2	WS8MM5V1-050-560	2	0	0	50	250	244	215	208	228	48.0	316
	3	WS8MM5V2-050-560	1	2	0	50	320	310	245	225	281	53.0	415
	3	WS8MM5V1-060-560	2	1	0	60	356	341	276	250	313	63.0	462
	3	WS8MM5V1-075-560	3	0	0	75	385	379	331	325	356	76.0	470
	4	WS8MM5V1-100-560	4	0	0	100	530	520	460	450	490	99.0	650
5	WS8MM5V1-125-560	5	0	0	125	663	650	570	560	610	123.0	810	

A Trim = 6.45"
B Trim = 5.937"
C Trim = 5.50"

Total Stages	HP	Weight (lbs)	Length (inches)	Standard Materials of Construction		Available Discharge Sizes (NPT)	Upgraded Bushing Material Options	Upgraded Shaft Material Options
1	15	104	27.19	Motor bracket	Ductile Iron	4", 6"	Vesconite	316SS, Chrome, Ion
2	20	141	34.62	Int. Bowl	Cast Iron (lined)			
2	25	141	34.62	Discharge	Ductile Iron			
2	30	141	34.62	Impeller	Stainless Steel			
2	40	141	34.62	Bushing	Bronze or rubber			
2	50	141	34.62	Collet	Stainless Steel			
3	50	178	42.06	Fasteners	Stainless Steel			
3	60	178	42.06	Shaft	416SS			
3	75	178	42.06	Sand Collar	Bronze			
4	100	215	49.5					
5	125	252	56.93					

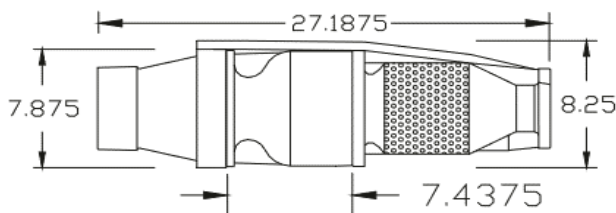

Important Note(s):
 Charted performance is based upon 3450rpm, and is guaranteed to ANSI/HI 14.6 acceptance grade 2B within the preferred range window indicated on the curve above.

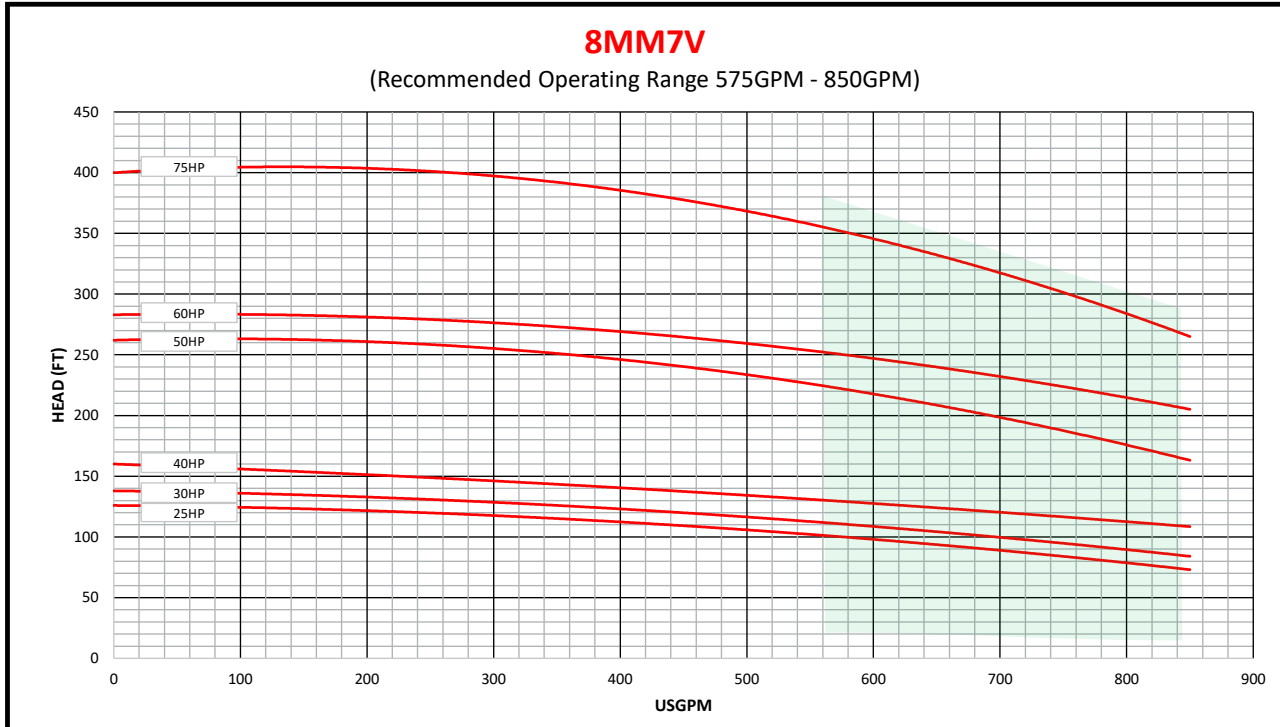

575 GPM		Wolf Item No	Recommended Operating Range 575GPM - 850GPM							850 GPM			
Model	Total Stages		A Trim Stages	B Trim Stages	C Trim Stages	HP	Head @ 575 GPM	Head @ 675 GPM	Head @ 800 GPM	Head @ 850 GPM	Head @ 750 GPM (BEP)	NOL HP	Shutoff Head
8MM7V	1	WS8MM7V1-025-750	0	0	1	25	99	92	79	72	85	26.5	126
	1	WS8MM7V1-030-750	0	1	0	30	111	100	90	83	97	30.1	138
	1	WS8MM7V1-040-750	1	0	0	40	130	122	113	109	115	38.0	160
	2	WS8MM7V1-050-750	0	0	2	50	222	203	173	164	190	50.0	262
	2	WS8MM7V1-060-750	1	0	1	60	250	236	214	205	225	62.0	283
	3	WS8MM7V1-075-750	0	0	3	75	350	327	282	265	303	78.0	400
	3	WS8MM7V1-100-750	3	0	0	100	425	405	381	369	390	106.0	477
	4	WS8MM7V1-125-750	1	3	0	125	548	521	479	461	499	130.0	622
	4	WS8MM7V1-150-750	4	0	0	150	584	556	524	508	540	140.0	656
	5	WS8MM7V2-150-750	3	0	2	150	678	641	587	563	613	157.0	765
5	WS8MM7V1-200-750	5	0	0	200	861	819	766	741	792	205.0	970	

A Trim = 6.45"
B Trim = 6.187"
C Trim = 6.0"

Total Stages	HP	Weight (lbs)	Length (inches)	Standard Materials of Construction		Available Discharge Sizes (NPT)	Upgraded Bushing Material Options	Upgraded Shaft Material Options
1	25	104	27.19	Motor bracket	Ductile Iron	4", 6"	Vesconite	316SS, Chrome, Ion
1	30	104	27.19	Int. Bowl	Cast Iron (lined)			
1	40	104	27.19	Discharge	Ductile Iron			
2	50	141	34.62	Impeller	Stainless Steel			
2	60	141	34.62	Bushing	Bronze or rubber			
3	75	178	42.03	Collet	Stainless Steel			
				Fasteners	Stainless Steel			
				Shaft	416SS			
				Sand Collar	Bronze			

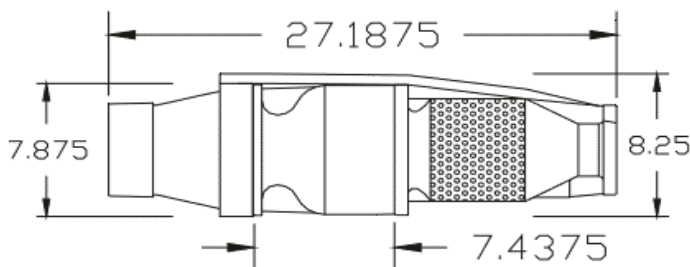

Important Note(s):

Charted performance is based upon 3450rpm, and is guaranteed to ANSI/HI 14.6 acceptance grade 2B within the preferred operating range window indicated on the curve above.

575 - 850 GPM

10" Well

100 - 200 HP

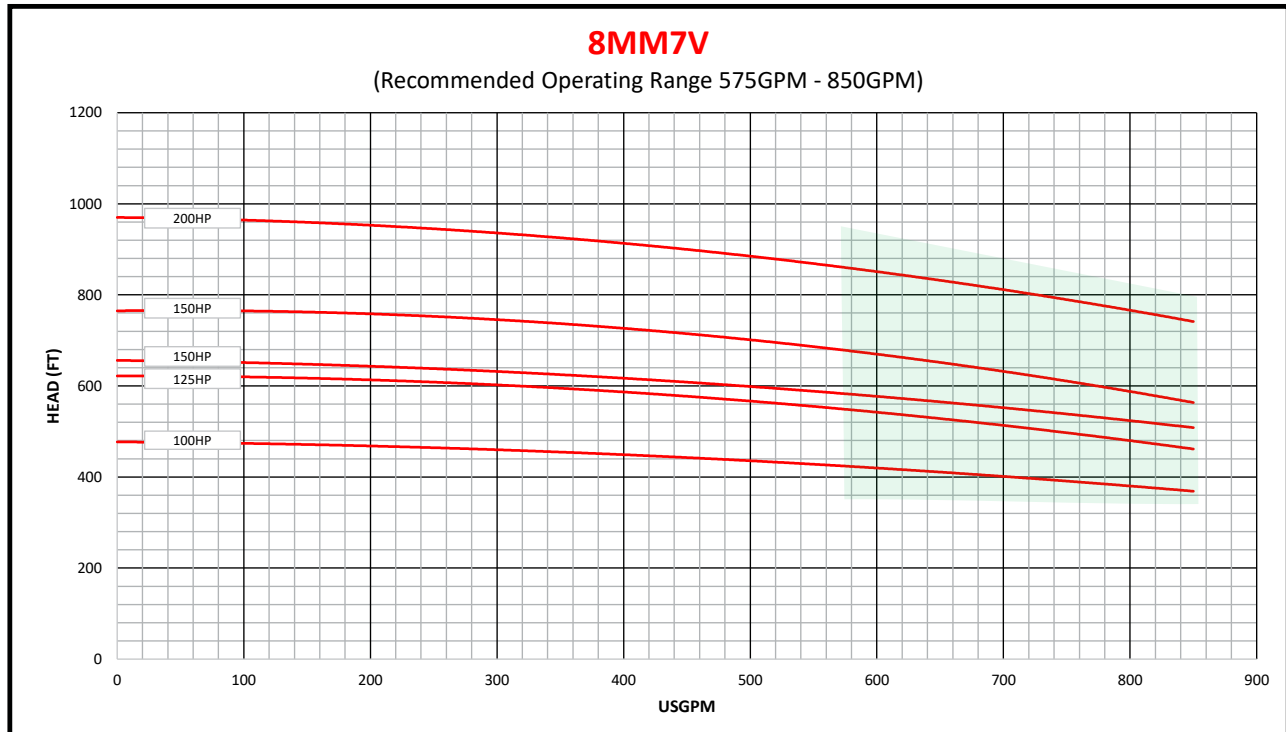

575 GPM		Wolf Item No	Recommended Operating Range 575GPM - 850GPM							850 GPM			
Model	Total Stages		A Trim Stages	B Trim Stages	C Trim Stages	HP	Head @ 575 GPM	Head @ 675 GPM	Head @ 800 GPM	Head @ 850 GPM	Head @ 750 GPM (BEP)	NOL HP	Shutoff Head
8MM7V A Trim = 6.45" B Trim = 6.187" C Trim = 6.0"	1	WS8MM7V1-025-750	0	0	1	25	99	92	79	72	85	26.5	126
	1	WS8MM7V1-030-750	0	1	0	30	111	100	90	83	97	30.1	138
	1	WS8MM7V1-040-750	1	0	0	40	130	122	113	109	115	38.0	160
	2	WS8MM7V1-050-750	0	0	2	50	222	203	173	164	190	50.0	262
	2	WS8MM7V1-060-750	1	0	1	60	250	236	214	205	225	62.0	283
	3	WS8MM7V1-075-750	0	0	3	75	350	327	282	265	303	78.0	400
	3	WS8MM7V1-100-750	3	0	0	100	425	405	381	369	390	106.0	477
	4	WS8MM7V1-125-750	1	3	0	125	548	521	479	461	499	130.0	622
	4	WS8MM7V1-150-750	4	0	0	150	584	556	524	508	540	140.0	656
	5	WS8MM7V2-150-750	3	0	2	150	678	641	587	563	613	157.0	765
5	WS8MM7V1-200-750	5	0	0	200	861	819	766	741	792	205.0	970	

Total Stages	HP	Weight (lbs)	Length (inches)	Standard Materials of Construction		Available Discharge Sizes (NPT)	Upgraded Bushing Material Options	Upgraded Shaft Material Options
1	25	104	27.19	Motor bracket	Ductile Iron	4", 6"	Vesconite	316SS, Chrome, Ion
1	30	104	27.19	Int. Bowl	Cast Iron (lined)			
1	40	104	27.19	Discharge	Ductile Iron			
2	50	141	34.62	Impeller	Stainless Steel			
2	60	141	34.62	Bushing	Bronze or rubber			
3	75	178	42.03	Collet	Stainless Steel			
				Fasteners	Stainless Steel			
				Shaft	416SS			
				Sand Collar	Bronze			

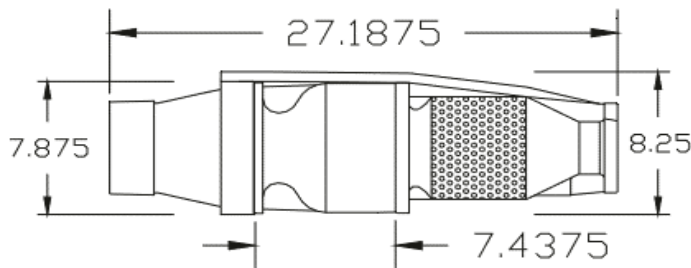

Important Note(s):
 Charted performance is based upon 3450rpm, and is guaranteed to ANSI/HI 14.6 acceptance grade 2B within the preferred operating range window indicated on the curve above.

TESTING *Tested here for your success out there*

- Pumps tested from 230V single phase to 6600V 3phase
- Testing includes vibration analysis, phase imbalance and stabilized motor temperature
- Remote testing is available, allowing customers to view their pumps during the test process, from anywhere in the world
- Every pump (up to 500HP) is wet-tested before it leaves the factory, ensuring every pump works the first time, every time.



- Skilled sales team to size and quote product needs quickly
- Committed to carrying inventory for the entire season
- Expert machinists and assemblers provide quality, custom pumps fast



Right Pump. Right Now. *What you need, when you need it.*

DOE Compliance

PUMP MODEL	Impeller Dia.	P.E.I.
5LL5V	4.125"	0.89
5LL8V	4.125"	0.87
5ML6V	4.515"	0.99
5MM6V	4.515"	0.93
5MM8V	4.515"	0.91
5MH6V	4.515"	0.98

PUMP MODEL	Impeller Diameter	P.E.I.
5MH7V	4.515"	0.96
5HH7V	4.125"	0.93
5HX7V	4.515"	0.87
6LL6V	4.515"	0.93
6LM6V	4.515"	0.88
6LM8V	4.515"	0.88

PUMP MODEL	Impeller Diameter	P.E.I.
6LH6V	4.515"	0.93
6LH7V	4.515"	0.91
6MM8V	4.75"	0.87
6HH7V	4.515"	0.99
6LH7V-SS	4.515"	0.96
6LM6V-SS	4.515"	0.92



WOLF™
CUSTOMIZED PUMPS
Right Pump. Right Now.®

FW0074
1021
Supersedes
1020

Centrifugal Pumps



FEATURING FLINT & WALLING'S SERVICE PLUS MOTORS

Model CJ103

- Low lead brass or thermoplastic impellers
- Capacities to 113 GPM
- Pressures to 45 PSI
- Discharge can be rotated to any one of four positions for horizontal or vertical positioning

CJ103
1/3, 1/2, 3/4, 1,
1-1/2, 2 and 3 HP

Model CJ101

- Low lead brass or thermoplastic impellers
- Capacities to 57 GPM
- Pressures to 95 PSI
- Multi-Stage for high head



CJ101, CJ103

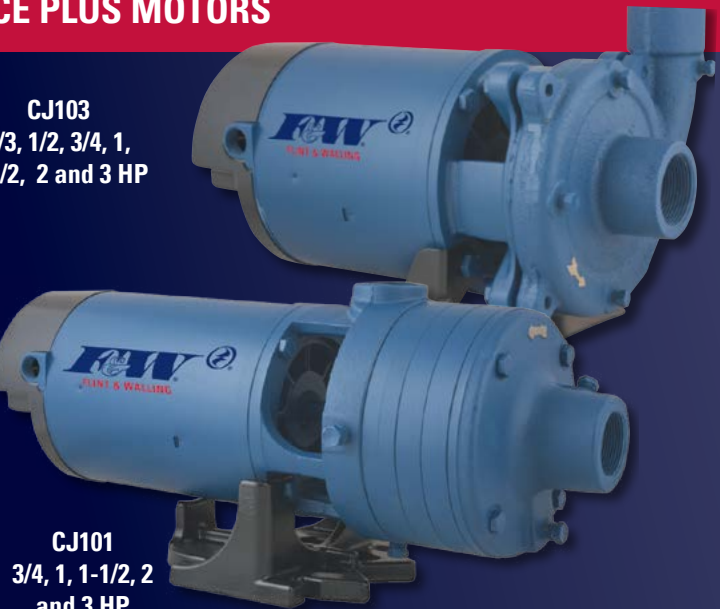

CJ101
3/4, 1, 1-1/2, 2
and 3 HP

Single or three phase

Suction lifts to 25 feet

Pressures to 95 PSI



Flint & Walling single and multi stage CJ103 and CJ101 centrifugal pumps are non-self priming with suction lifts up to 25 feet. Applications include booster service, water circulation, liquid

transfer, cooling systems, jockey pump service and general service in farm, commercial and industrial applications.

COMPONENT DESCRIPTION	CJ103 SERIES 1/3 THROUGH 3 HP SINGLE STAGE MODELS	CJ101 SERIES 3/4 THROUGH 3 HP TWO & THREE STAGE MODELS
Suction Body	Cast iron w/low lead brass clearance ring. Discharge port rotates in 90° increments. 1/4" vacuum tappings and drain plugs.	Cast iron w/low lead brass clearance ring and 1/4" vacuum tapping.
Impeller(s)	Closed low lead brass or closed thermoplastic	Closed low lead brass or closed thermoplastic
Gasket(s)	Buna-N square cut ring	Lexide gasket, Buna-N square cut ring
Intermediate Stage(s)	Not applicable	Cast iron w/brass suction and hub clearance rings
Shaft Seal	Silicon carbide, stainless steel spring, and Buna-N	Silicon carbide, stainless steel spring, and Buna-N
Mounting Ring	Cast iron body	Cast iron body, 1/4" tapping for applications requiring a pressure switch
Pump Shaft	Threaded 416 stainless steel	Threaded 416 stainless steel
Base	Rigid steel base assembly	Heavy cast iron base assembly
 Motor	All CJ101 and CJ103 single phase (with ODP motors) pumps feature Flint & Walling's Service Plus 56 frame NEMA J, single or dual voltage ODP motors with permanently lubricated double ball bearing. NOTE: CJ103 pumps with TEFC motors feature purchased motors. Single or three phase options. TEFC motors available on selective models.	

Open Drip Proof (ODP) motor voltage
 CJ101 Single Phase: 3/4 through 2 HP - 115/230V;
 3 HP - 230V, 60HZ
 CJ103 Single Phase: 1/3 through 3/4 HP - 115/230V, 60/50HZ;
 1 through 3 HP, 230V, 60HZ
 CJ101 Three Phase: 3/4 through 2 HP - 208-230V/460V, 50/60HZ
 3 HP - 208-230/460V; 60HZ
 CJ103 Three Phase: 1/2 through 3/4 HP - 208-230V/460V, 50/60HZ

Totally Enclosed Fan Cooled (TEFC) motor voltage
 Single Phase: 1/2 through 3 HP - 115/230V 60/50HZ
 Three Phase: 1/2 through 3 HP - 208-230/460V 60/50HZ

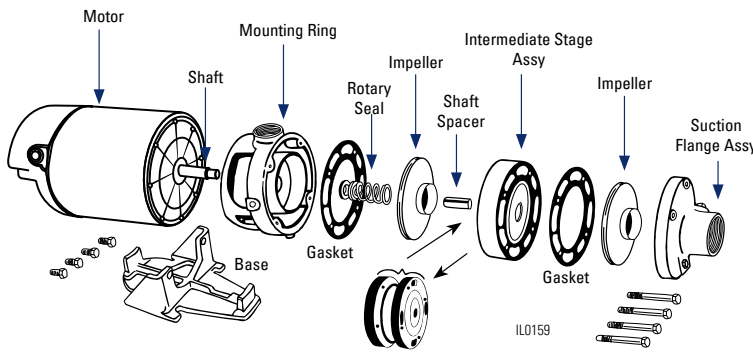

CJ101 SERIES

Product may not be exactly as shown.

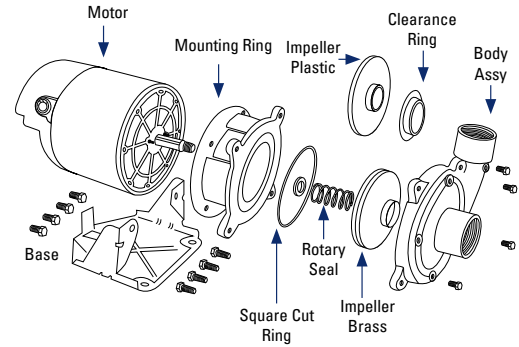

CJ103 SERIES

CJ103 1/2, 3/4 and 1 HP series also available with autophoretic coating on inside of castings.
 Add suffix PC to Model No. Example: CJ103101PC.

**In order to follow DOE P.E.I. requirements, single phase CJ103201 pumps will ship with a 3 HP motor.

CJ103 DOE Compliance

PUMP MODEL	Impeller Dia.	P.E.I.cl.	PUMP MODEL	Impeller Dia.	P.E.I.cl.	PUMP MODEL	Impeller Dia.	P.E.I.cl.
CJ103101	4.870"	0.98	CJ103P151	5.090"	0.90	CJ103103T	4.870"	0.91
CJ103151	5.090"	0.99	CJ103101T	4.870"	0.99	CJ103153T	5.090"	0.93
CJ103201	5.090"	0.98	CJ103151T	5.090"	0.99	CJ103203T	5.090"	0.91
CJ103P101	5.000"	0.98	CJ103201T	5.090"	0.99			

CJ101 Performance



PUMP PERFORMANCE

CJ101 SERIES CENTRIFUGAL PUMPS, LOW LEAD BRASS IMPELLERS													MAX. PRESS. PSI	*MAX. CASE PRESS.	*MAX. LIQUID TEMP.		
MODEL NO.			HP	STAGES	LIFT FT.	Discharge Pressure PSI											
1 PHASE	3 PHASE	LESS MOTOR				10	20	30	40	50	60	70				80	90
CAPACITY U.S. GPM																	
CJ101B071AB CJ101B071TAB	CJ101B073AB CJ101B073TAB	CJ101B0710AB	3/4	2	5 15 25	39 38 31	34 33 29	29 26 23	21 18 12	5				54	160psig	200° F	
CJ101B101AB CJ101B101TAB	CJ101B103AB CJ101B103TAB	CJ101B1010AB	1	2	5 15 25	42 40 32	38 36 31	33 31 28	26 24 21	18 14				62	160psig	200° F	
CJ101B151AB CJ101B151TAB	CJ101B153AB CJ101B153TAB	CJ101B1510AB	1 1/2	2	5 15 25	48 44 34	44 42 33	39 37 32	34 31 24	27 24 20	17 10			69	160psig	200° F	
CJ101B201AB CJ101B201TAB	CJ101B203AB CJ101B203TAB	CJ101B2010AB	2	2	5 15 25	56 50 37	52 49 36	47 45 35	41 39 34	34 31 27	24 19			70	160psig	200° F	
CJ101C201AB CJ101C201TAB	CJ101C203AB CJ101C203TAB		2	3	5 15 25	49 45 35	47 44 34	43 42 33	40 39 32	36 35 29	32 31 23	28 26 15	12	98	160psig	200° F	
CJ101C301AB CJ101C301TAB	CJ101C303AB Δ CJ101C303TAB		3	3	5 15 25	56 50 37	54 49 36	51 48 36	48 46 35	44 42 34	39 37 29	33 31 20	18	95	160psig	200° F	

Δ Less than 50% US content

CJ101 SERIES CENTRIFUGAL PUMPS, PLASTIC IMPELLERS													MAX. PRESS. PSI	*MAX. CASE PRESS.	*MAX. LIQUID TEMP.		
MODEL NO.			HP	STAGES	LIFT FT.	Discharge Pressure PSI											
1 PHASE	3 PHASE					10	20	30	40	50	60	70				80	90
CAPACITY U.S. GPM																	
CJ101P071	CJ101P073		3/4	2	5 15 25	41 38 32	35 32 29	28 26 22	20 13					49	160psig	160° F	
CJ101P101	CJ101P103		1	2	5 15 25	45 42 35	40 39 33	35 28 22	20					60	160psig	160° F	
CJ101P151	CJ101P153		1 1/2	2	5 15 25	54 48 37	50 46 35	44 42 33	38 35 28	28				61	160psig	160° F	
CJ101P201	CJ101P203		2	2	5 15 25	55 49 37	52 47 36	47 45 33	41 39 32	34 30 26	23 17			67	160psig	160° F	
CJ101D201	CJ101D203		2	3	5 15 25	44 36 26	44 36 24	44 36 24	41 36 24	37 30 22	32 25 20	28 20 15	16	101	160psig	160° F	
	CJ101D303		3	3	5 15 25	54 48 36	52 47 36	50 46 35	47 44 35	44 37 31	39 30 27	33 22 19	15	95	160psig	160° F	

*Do not exceed the maximum case pressure and maximum liquid temperature rating of the pump. Performance shown for 60Hz models. 50 Hz models also available. Suction and Discharge Tappings 1-1/2" X 1-1/4"

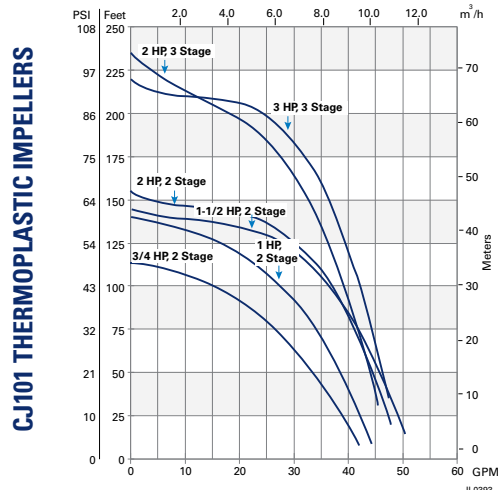
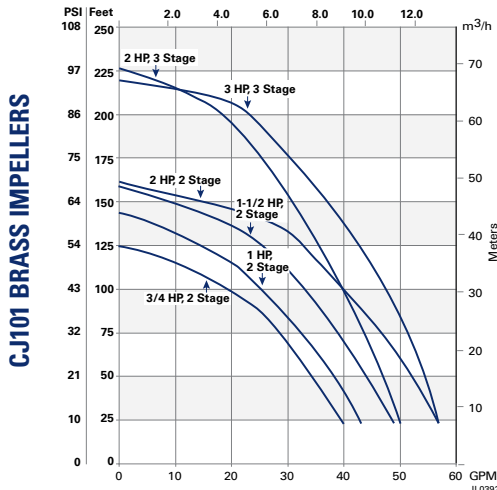

PUMP PERFORMANCE

CJ103 SERIES CENTRIFUGAL PUMPS, LOW LEAD BRASS IMPELLERS																	
MODEL NO.		HP	STAGES	LIFT FT.	Discharge Pressure PSI										MAX. PRESS. PSI	*MAX. CASE PRESS.	*MAX. LIQUID TEMP.
1 PHASE	3 PHASE				10	15	20	25	30	35	40	45	50				
					CAPACITY U.S. GPM												
CJ103031AB		1/3	1	5 15 25	42 36 28	34 26	21							27	100psig	200° F	
CJ103051AB		1/2	1	5 15 25	50 43 33	47 40 30	37 29 15	25						32	100psig	200° F	
CJ103071	CJ103073	3/4	1	5 15 25	71 66 57	62 54 43	51 40 25	36 19	11					32	100psig	200° F	
CJ103101	CJ103103T	1	1	5 15 25	76 73 66	69 65 57	61 54 45	50 29	36 24	16				39	100psig	200° F	
CJ103151	CJ103153T	1 1/2	1	5 15 25	94 92 74	88 85 72	80 75 66	70 49 52	59 27	44 18				43	100psig	200° F	
CJ103201		3	1	5 15	109 109	103 103	96 94	86 82	75 67	61 45	39			44	100psig	200° F	
CJ103201T	CJ103203T	2		5	90	89	85	71	51								

CJ103 SERIES CENTRIFUGAL PUMPS, PLASTIC IMPELLERS																	
MODEL NO.		HP	STAGES	LIFT FT.	Discharge Pressure PSI										MAX. PRESS. PSI	*MAX. CASE PRESS.	*MAX. LIQUID TEMP.
1 PHASE	3 PHASE				10	15	20	25	30	35	40	45	50				
					CAPACITY U.S. GPM												
CJ103P031		1/3	1	5 15 25	43 35 26	35 24	21							26	100psig	160° F	
CJ103P051	CJ103P053	1/2	1	5 15 25	45 41 31	45 41 29	44 38 27	36 24	19					32	100psig	160° F	
CJ103P071	CJ103P073	3/4	1	5 15 25	69 64 49	68 62 48	64 57 45	57 46 31	42 28	20				38	100psig	160° F	
CJ103P101		1	1	5 15 25	67 61 47	65 59 46	64 58 45	62 55 43	51 41 23	35				40	100psig	160° F	
CJ103P151		1 1/2	1	5 15 25	68 62 48	67 61 47	66 60 46	65 59 45	63 55 41	52 39	31			44	100psig	160° F	

*Do not exceed the maximum case pressure and maximum liquid temperature rating of the pump. Performance shown for 60Hz models. 50 Hz models also available. Models with suffix T denotes TEFC motor. All other models utilize ODP motors. Suction and Discharge Tappings 1-1/2" X 1-1/4"

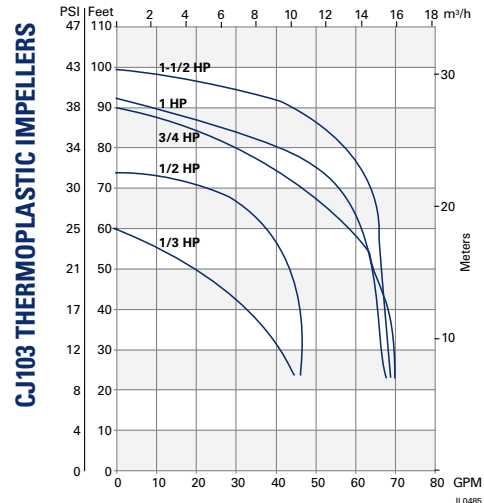
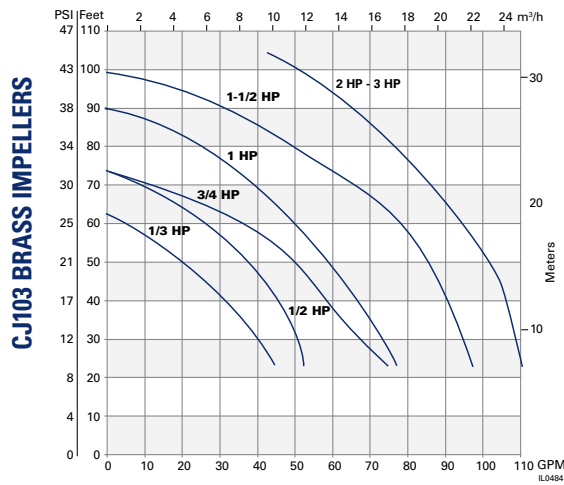

CENTRIFUGAL PUMPS

FW0176
1020
Supersedes
1219

High Performance for Industrial Demands

- The C22000 Series is a rugged pump built for extra performance.
- Nationally known NEMA JM motors.
- Electronically balanced brass impellers.
- Capacities to 8,580 gallons per hour.
- Pressures to 85 PSI
- 3" Suction



C22000 SERIES



3 thru 7-1/2 HP

Single Phase or Three Phase

Two Stage

PERFORMANCE

MODEL NUMBER		HP	STAGES	DISCHARGE PRESSURES (PSI)						MAX SUCTION LIFT (FT)	SUCTION PIPE TAP (NPT)	DISCH PIPE TAP (NPT)	
1 PHASE	3 PHASE			20	30	40	50	60	70				80
CAPACITY - U.S. GALLONS PER MINUTE (0 LIFT)													
C22231	C22233	3	2	95	86	75	60	40	12		20	3	2
C22251	C22253	5	2	143	137	124	111	91	65		20	3	2
--	C22273	7 1/2	2	145	140	138	135	121	95	75	20	3	2

MOTOR VOLTAGE: 3HP 1 Phase 208-230V 60 Hz, 5HP 1 Phase 208-230V 60Hz, 3, 5 & 7.5HP 3 Phase 208-230/460V 60Hz.
120 PSI Maximum Case Pressure

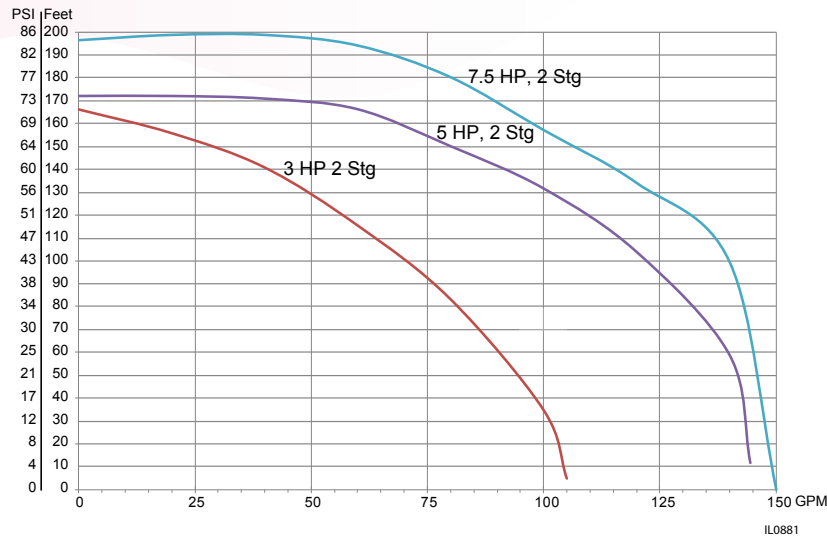

Ref No.	Description
1	Heavy-duty NEMA JM motor 3, 5, 7-1/2 HP
2	Heavy duty cast iron mounting ring
3	1-1/4" Rotary seal
4	Gasket
5	Heavy duty cast iron Intermediate stage

Ref No.	Description
6	Heavy duty cast iron body
7	Motor mounting bolts
8	Electronically balanced brass impellers
9	Brass impeller retainer and stainless steel lock screw
10	Pump through bolts

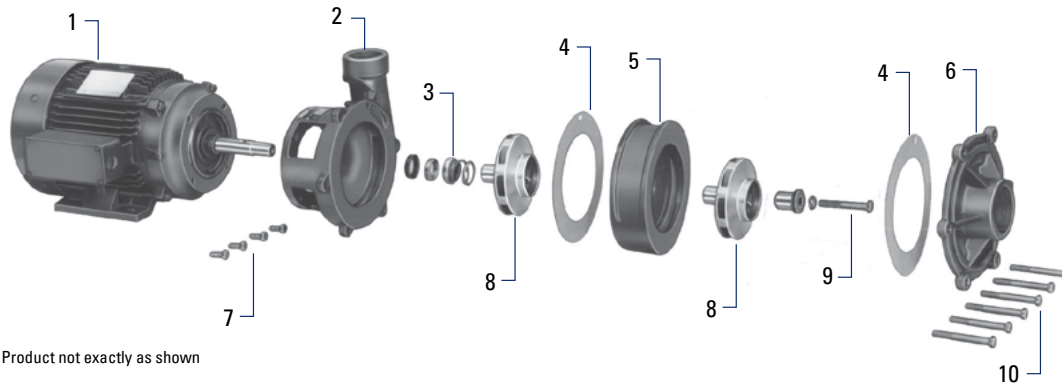



LAWN SPRINKLER PUMPS

FW0075
1020
Supersedes
0319

For lawn and turf sprinkling, irrigation and water transfer

SPJ Self-Priming

- High capacity, high volume
- Cast iron pump body and mounting ring for long life
- Flint & Walling's Service Plus NEMA J, capacitor start, double ball bearing motors for continuous operation
- Easy access drain plug
- Rapid self-priming characteristics under maximum suction conditions



SPJ SERIES

Single or Three Phase

SPJ 3/4 - 3 HP

SPJ SELF-PRIMING 3/4 - 3 HP SINGLE OR THREE PHASE

PERFORMANCE CHART

Model Number		HP	Suction Lift Ft.	Discharge Pressure PSI								Shut-Off Pressure PSI	Suction Pipe Tap	Disch. Pipe Tap
				10	15	20	25	30	35	40	45			
1 Phase	3 Phase	Capacity - U.S. Gallons per Minute												
SPJ07P1	SPJ07P3	3/4	5	56	48	42	37	29	21			41	2"	1-1/2"
			15	47	42	37	29	22	12		37			
			25	43	37	31	22	10		33				
SPJ10P1	SPJ10P3	1	5	58	53	48	43	38	32	23	11	48	2"	1-1/2"
			15	53	48	45	37	31	24	12	43			
			25	48	44	38	33	25	14		39			
SPJ15P1 SPJ15B1	SPJ15B3	1-1/2	5	78	77	74	70	62	53	43	30	47	2"	1-1/2"
			15	70	68	66	62	53	43	30	41			
			25	47	46	45	44	42	34		36			
SPJ20B1	SPJ20B3	2	5	86	84	81	77	71	62	52	40	50	2"	1-1/2"
			15	76	74	72	69	64	55	43	25	45		
			25	52	51	50	47	45	42	30		40		
SPJ30B1	SPJ30B3**	3	5	88	86	85	84	80	73	64	53	54	2"	1-1/2"
			15	77	76	75	74	72	65	55	43	50		
			25	54	53	52	51	50	49	45	10	45		

Motor voltage: Single Phase 3/4 - 2 HP - 115/230V; 3 HP - 230V, 60Hz
 Three Phase 3/4 - 2 HP - 208 - 230/460V, 50/60Hz; 3 HP - 208 - 230/460V; 60Hz
 Maximum Case Pressure: 100 PSI

**Less than 50% US content

PERFORMANCE CURVES / SPECIFICATIONS

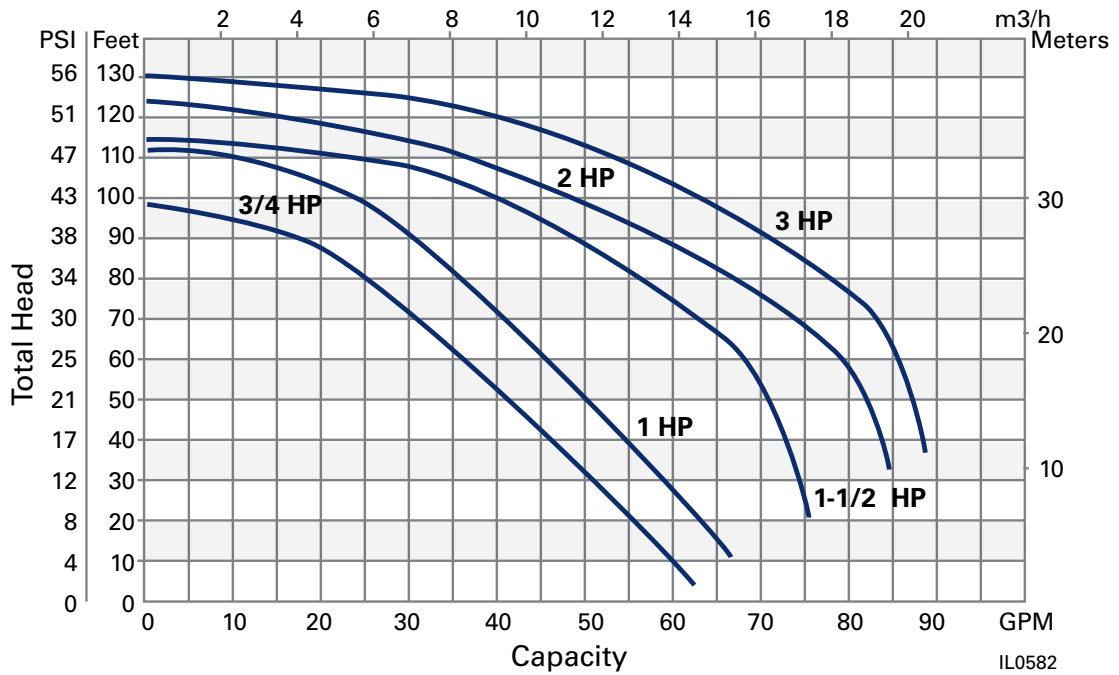

SPJ SELF-PRIMING 3/4 - 3 HP SINGLE OR THREE PHASE

SPECIFICATIONS

HP	Type	Volts	Hz	RPM	Motor Voltage (Factory) Connected	Service Factor Motor Amps				Max Liquid Temp	Max Suction Lift
						Single Phase		Three Phase			
						115V	230V	230V	460V		
3/4	Single Ph	115/230	60	3450	115V	14.0	7.0	-	-	180°F	25 Ft.
1						18.0	9.0				
1-1/2						21.0	10.5				
2						25.0	12.5				
3						-	13.5				
3/4	Three Ph	208-230/460	60/50	3450/2850	230V	-	-	3.5	1.75	180°F	25 Ft.
1								4.5	2.25		
1-1/2								5.7	2.85		
2								7.4	3.70		
3								9.8	4.90		

Suction lift varies, depending upon elevation (altitude) and water temperatures.

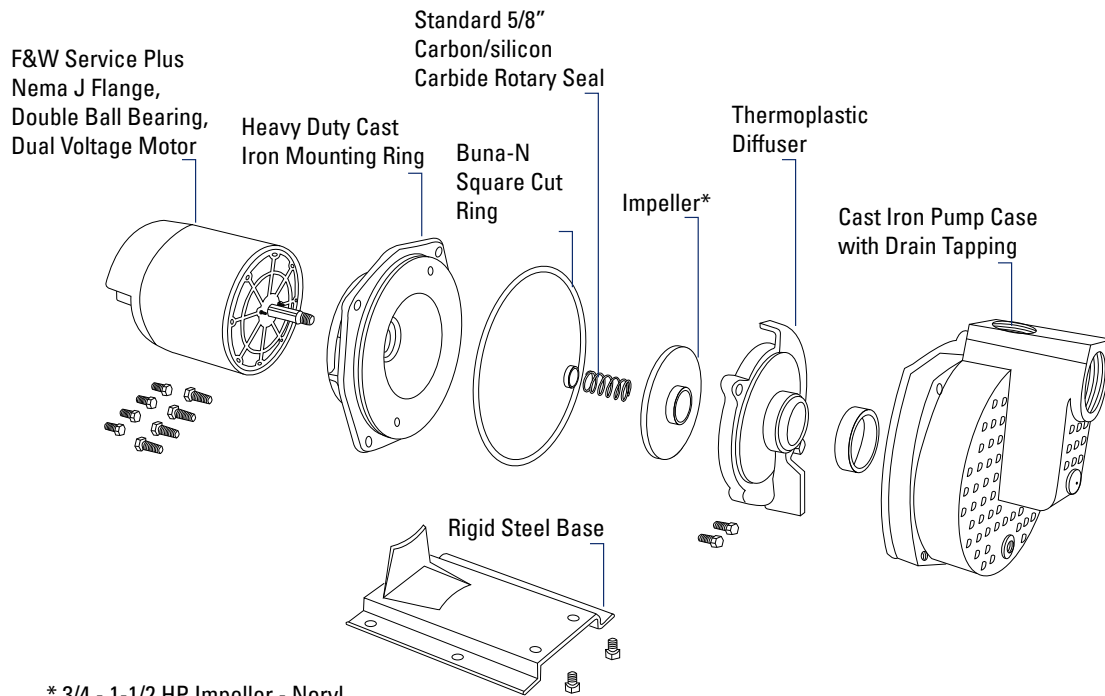

* 3/4 - 1-1/2 HP Impeller - Noryl
 1-1/2 - 3 HP Impeller - Brass



FW1298
0920
Supersedes
0619

LAWN SPRINKLING PUMPS

SP SELF PRIMING LAWN SPRINKLING / IRRIGATION PUMPS

- Quick self-priming operation for lawn irrigation
- Flint & Walling's Service Plus motor featuring capacitor start and sealed ball bearings for continuous operation.
- Heavy-duty cast-iron construction
- 115/230 Dual voltage motor
- Easy access drain plug
- 2 in. suction pipe / 1-1/2 in. discharge pipe



SP SERIES

1, 1-1/2 and 2 HP



SP Series Performance



Lawn Sprinkling Pumps

PERFORMANCE CHART												
Model #	HP	Suction Lift (Ft.)	Discharge Pressure (PSI)							Shut Off Pressure @ 0 Lift (PSI)	Suction Pipe	Discharge Pipe
			15	20	25	30	35	40	45			
Capacity - U.S. Gallons per Minute												
SP10P1	1	5	65	61	53	44	32			39	2 in.	1-1/2 in.
		10	64	58	49	39	24					
		15	62	55	45	34						
		20	59	51	41	28						
		25	56	46	36	2						
SP15P1	1-1/2	5	66	63	59	54	48	40	8	45	2 in.	1-1/2 in.
		10	64	61	57	52	45	28				
		15	63	60	55	49	41	15				
		20	62	58	53	46	32					
		25	60	56	50	42	21					
SP20P1	2	5	70	68	65	62	56	46	24	48	2 in.	1-1/2 in.
		10	69	66	63	60	52	39	6			
		15	68	65	62	57	47	27				
		20	67	64	60	53	41	13				
		25	65	62	58	48	30					

Max. Case Pressure: 100 PSI

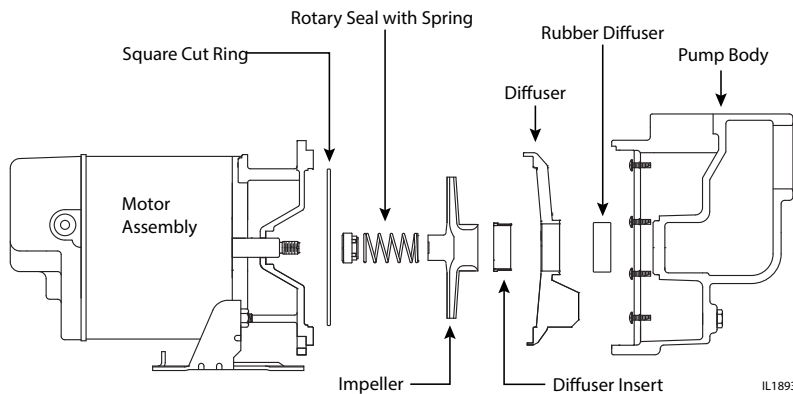
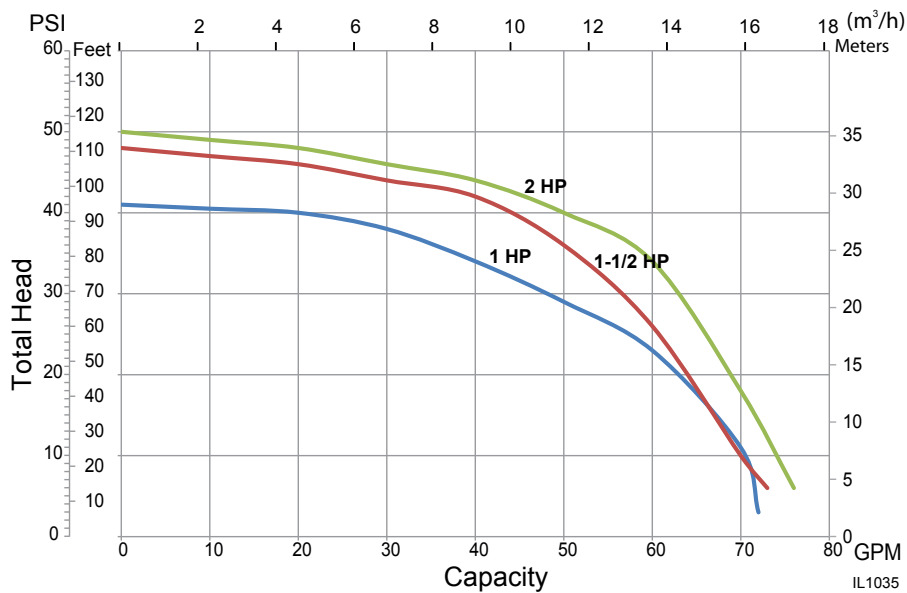

HIGH POWER CENTRIFUGALS

FW1914
1020
Supersedes
0818



SPM SERIES SELF-PRIMING 3 & 5 HP

EASY REPLACEMENTS

- Replace current 3 & 5 HP centrifugals without disrupting plumbing. The SPM series is designed to be easily swapped without the difficulties of changing piping, flapper valves, or other tedious plumbing work.

TRIM YOUR PRIME TIME

- Achieve prime in less than one minute.

ENGINEERED BY FLINT & WALLING

- Powered by Baldor
- Available in single or three phase



MODEL SPM

Suction flange (sold separately)

Flows up to 150 GPM

TDH up to 160 feet

3 & 5 HP High Power Centrifugal Pumps

SPECIFICATIONS

MODEL NUMBER	SPM301/303	SPM501/503
HP	3	5
Voltage	208-230/460V	
Current	8.2-7.4/3.7 Amp	13.0-12.2/6.1 Amp
Phase	SPM301 - single, SPM303 - three	SPM501 - single, SPM503 - three
Motor Frame	145JM	182JM
Impeller	Low lead brass	
Diffuser	Cast iron	
Pipe Plug	Stainless steel 1/4" NPT	
Seal	John Crane type 2100 1-1/4"	
O-Rings	Buna N	
Suction Tapping	2"	2-1/2"
Suction Flange*	6" ANSI 125 bolt flange pattern	
Ambient Air Temp	40° - 104° F	
Water Temp	55° - 200° F	
Max Case Pressure	120 PSI	

*Suction flange sold separately
 3 HP - 024912, 5 HP - 024913

PERFORMANCE CURVES

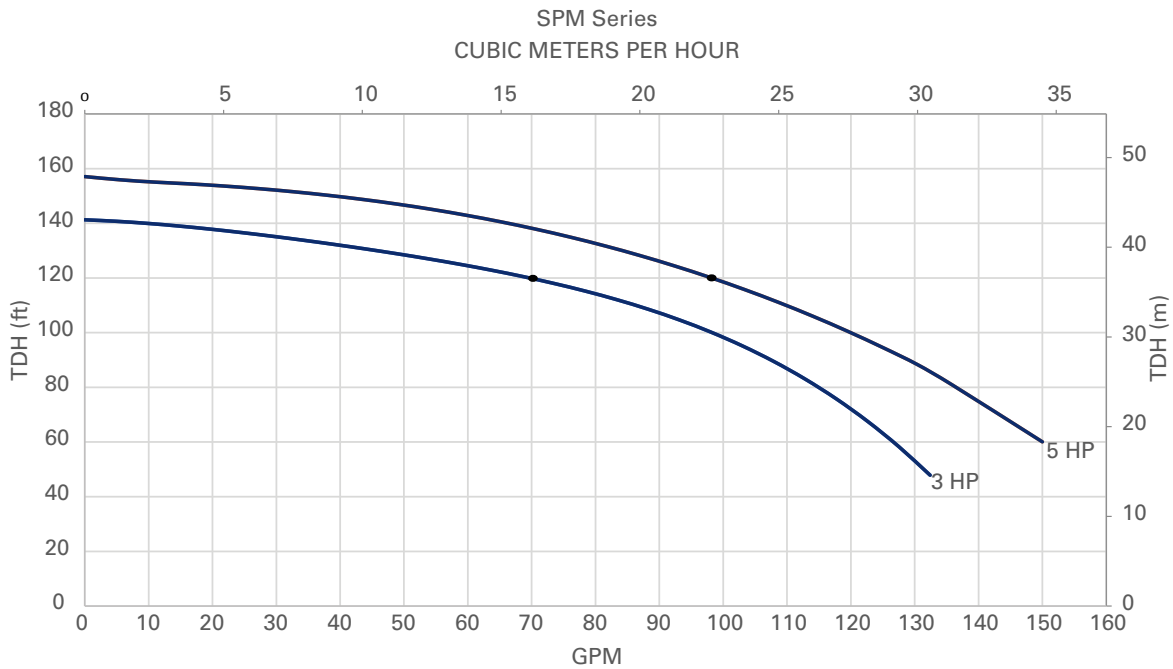

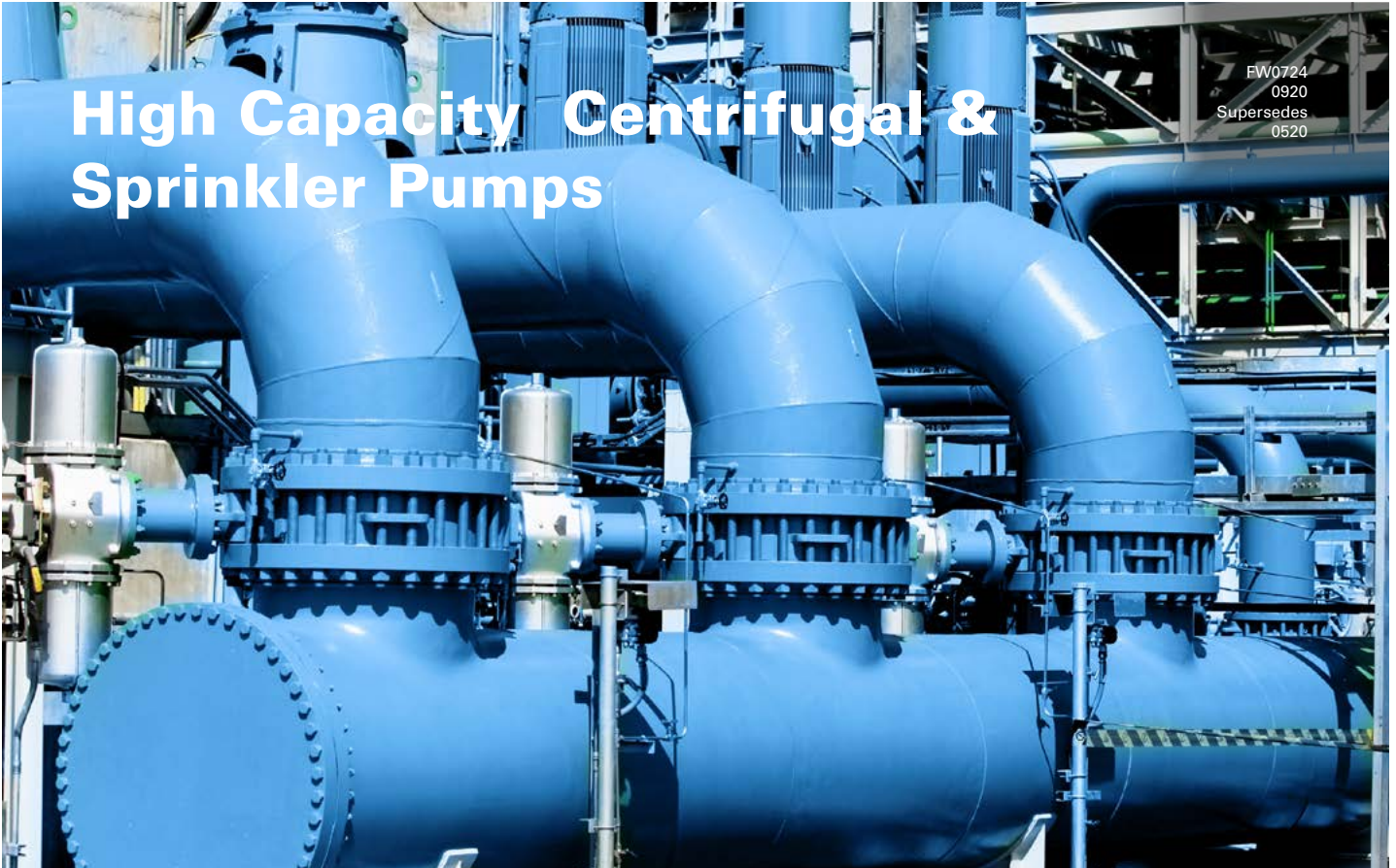

FW0724
0920
Supersedes
0520

High Capacity Centrifugal & Sprinkler Pumps

FOR HOME, FARM AND INDUSTRY

- Stainless steel or cast iron construction
- Stainless steel impellers
- Discharge rotates in 90° increments on some models
- Maximum temperatures to 200° F



C3, C4, C5,
C6 SERIES

Heavy Duty Straight Centrifugal Pumps

Stainless Steel Straight Centrifugal Pumps

Straight Centrifugal Pumps

High Head Straight Centrifugal Pumps

Sprinkler Booster Pumps



Single or three phase

Pressures to 150 PSI



US

Electric Motors

"C3" Series Straight Centrifugal Pumps



- Investment cast 316 stainless steel
- Viton® mechanical seal and o-ring
- Discharge port rotates in 90° increments
- Max. working pressure 75 PSI
- Max. temperature 200° F
- Max. flow 90 GPM
- Max. head 65 ft. (28 PSI)
- Self-cleaning, semi-open stainless steel impellers with solids handling capacity of less than 1/8".
- Totally enclosed fan cooled (TEFC) 56J motors
- 1/2 HP to 2 HP single and three phase, 3450 RPM motors



F&W straight centrifugal pumps are designed for continuous-duty low pressure OEM, industrial/commercial and general service applications including circulation, liquid transfer and cooling. Applications include, but are not limited to dry cleaning, transferring deionized water, candle manufacturing and parts washers.

These durable and compact pumps are available in a variety of construction and seal materials to meet your specification. The line also features a wide selection of single and three phase TEFC motors, up to 2 horsepower.

All models feature Type 6 mechanical seals and O-rings. Pull-from-the-rear design for easy service without disturbing any piping. Self-cleaning impellers to prevent clogging and minimize maintenance.

PERFORMANCE

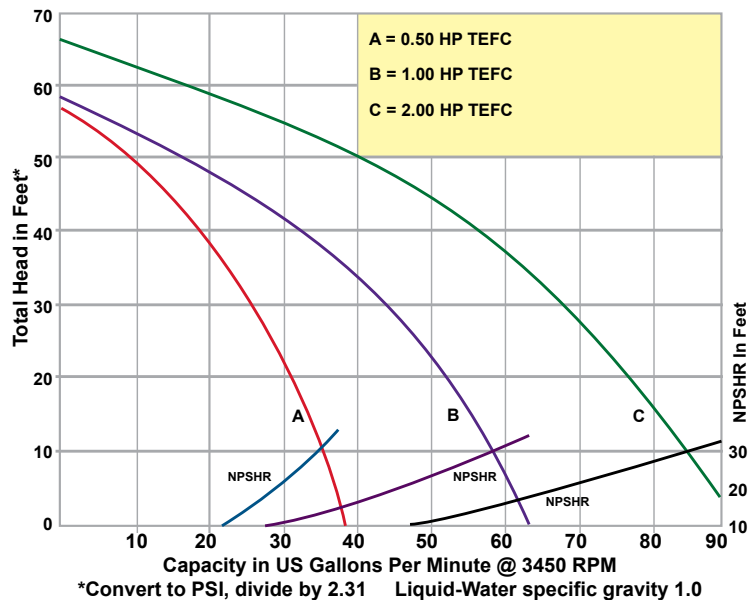

"C3" Series Straight Centrifugal Pumps

PUMP DIMENSIONAL & SPECIFICATION CHART

Model	HP	PH	Encl	Voltage @ 60 Hz $\pm 10\%$	Full Load Amp	SUC*	DIS*	AB**	CP	L	X	Y	Z	ZZ	Ship Wt. Lbs.
C31S051T	1/2	1	TEFC	115/230	9/5	3/4"	1/2"	2.4	13.3	6.3	1.9	1.4	1.9	2.9	33
C31S053T	1/2	3	TEFC	230/460	3/2	3/4"	1/2"	2.4	13.1	6.3	1.9	1.4	1.9	2.9	31
C32S101T	1	1	TEFC	115/230	12/6	1"	3/4"	3.0	15.1	6.3	2.4	1.3	2.1	3.3	39
C32S103T	1	3	TEFC	230/460	4/2	1"	3/4"	3.0	14.2	6.3	2.4	1.3	2.1	3.3	36
C33S201T	2	1	TEFC	115/230	22/11	1-1/4"	1"	3.0	15.4	6.3	2.5	1.3	2.0	3.4	52
C33S203T	2	3	TEFC	230/460	6/3	1-1/4"	1"	3.0	14.3	6.3	2.5	1.3	2.0	3.4	50

(*) Standard NPT (female) pipe thread.

(**) This dimension may vary due to motor manufacturer's specifications

(+) 3-Phase motors can also operate on 50 Hz. (This will change the Full Load Amps, Service Factor and RPM)

NOTE: Dimensions have a tolerance of $\pm 1/8"$

NOTE: Electric supply for ALL motors must be within $\pm 10\%$ of nameplate voltage rating (ex. 230V $\pm 10\%$ = 207 to 253)

All 316 Stainless Steel Construction with Viton® Seals, Max. Temperature 200° F

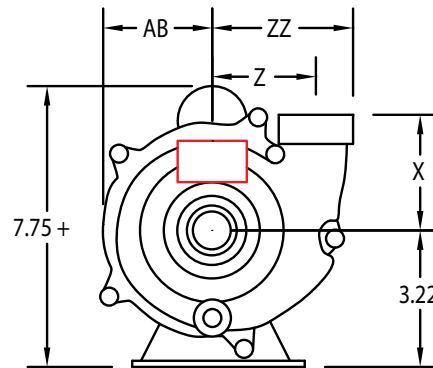
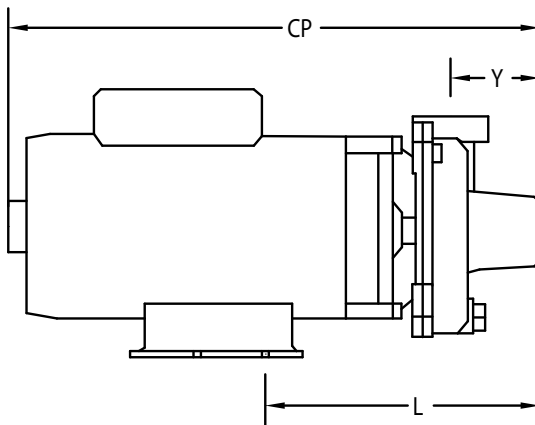

IL1423

STANDARD FEATURES

- 316 Investment cast stainless steel construction
- Viton® mechanical seal
- Stainless steel hardware
- NEMA 56J TEFC single and three phase motors
- Stainless steel motor shaft
- NEMA base mounted motors
- Self-cleaning stainless steel impeller
- Discharge rotates in 90° Increments
- Max. working pressure to 75 PSI
- Max. temperature 200° F Viton®
- Front drain plug

"C5" Series Heavy Duty Straight Centrifugal Pumps



- Investment cast 316 stainless steel construction with Viton seals or cast iron construction with Buna seals
- Stainless steel impellers with solids handling capacity of 1/8 - 3/16".
- 3 HP to 15 HP NEMA JM motors, three phase TEFC
- High flow and high head designs
- Max. temperature
SS - Viton®: 200° F
CI - Buna N: 180° F
- Front drain plugs located 90° apart
- Max head 194 Ft. (100 PSI)
- Max flow 425 GPM
- Max working pressure 150 PSI



F&W Heavy Duty Straight Centrifugal pumps are suited for liquid transfer, heating and cooling, recirculation, booster service and other industrial applications. Applications include, but are not limited to cooling towers and car washes.

Stainless Steel units are especially effective in applications where rust and/or corrosion can develop in systems. Semi-open impeller features self-cleaning ability that makes the unit useful in applications involving muddy or dirty liquids as well as clean, clear fluids.

Discharge position can be adjusted in 90° increments with vent and drain plugs for all positions. Type 21 mechanical seal and O-ring casing seal. Pumps are close-coupled to totally enclosed fan cooled (TEFC) motors. Pumps are not self-priming and require flooded suction.

PERFORMANCE

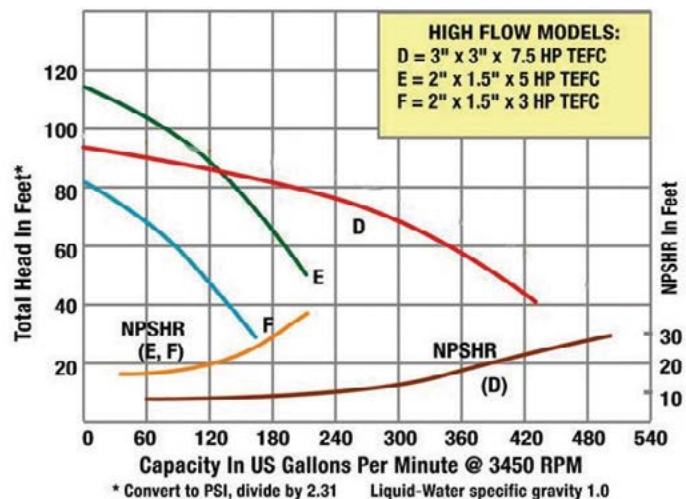
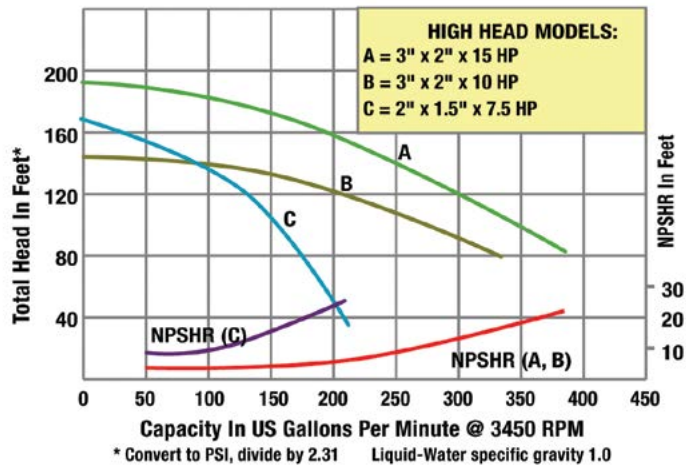

"C5" Series Heavy Duty Straight Centrifugal Pumps

PUMP DIMENSIONAL & SPECIFICATION CHART

Model No.	Model No.	Curve	HP	PH	Frame	Encl	Voltage @ 60 Hz ±10%	Full Load Amps	S.F. Amp	Connect Type	Suct*	Dischl*	AB**	Cp**	D	E	F	H1	H2	L	LP	MP	O	X	Y	Z	ZZ	Ship Wt (Lbs.)	
																												CI	SS
C55A303T	C55S303T	F	3		182JM	TEFC	230/460	8/4	9/4.5	NPT	2"	1-1/2"	7.5	21.6	4.5	3.8	4.5	0.4	0.4	12.7	4.1	4.0	9.3	4.8	2.5	4.0	N/A	98	83
C55A503T	C55S503T	E	5		184JM			17/9	20/10		2"	1-1/2"	7.5	21.6	4.5	3.8	5.5	0.4	0.4	11.8	4.1	4.0	9.3	4.8	2.5	4.0		108	100
C57A753T	C57S753T	D	7.5	3	184JM			22/11	25/12.5		3"	3"	7.5	22.4	4.5	3.8	5.5	0.4	0.4	12.5	4.1	4.8	9.3	6.5	2.8	4.5		122	117
C55A753T	C55S753T	C	7.5		184JM			22/11	25/12.5		2"	1-1/2"	7.5	21.4	4.5	3.8	5.5	0.4	0.4	11.5	3.5	4.4	9.3	5.9	2.4	3.8		105	108
C56A1003T	C56S1003T	B	10		215JM	26/13	30/15	3"	2"	8.3	26.0	5.3	4.3	7.0	0.4	0.4	11.7	3.5	4.5	10.9	5.0	2.8	4.8	173	176				
C56A1503T	C56S1503T	A	15		215JM	47/24	54/27	3"	2"	8.3	26.0	5.3	4.3	7.0	0.4	0.4	12.5	3.5	4.5	10.9	5.0	2.8	4.8	190	195				

(* Standard NPT (female) pipe thread.

(**) This dimension may vary due to motor manufacturer's specifications

(+) 3-Phase motors can also operate on 50 Hz. (This will change the Full Load Amps, Service Factor and RPM)

NOTE: Dimensions have a tolerance of ± 1/8"

NOTE: Electric supply for ALL motors must be within ± 10% of nameplate voltage rating (ex. 230V ± 10% = 207 to 253)

CI = Cast Iron Construction with SS Impeller and Buna N Seals, Max. Temperature 180° F

SS = All 316 Stainless Steel Construction with Viton® Seals, Max. Temperature 200° F

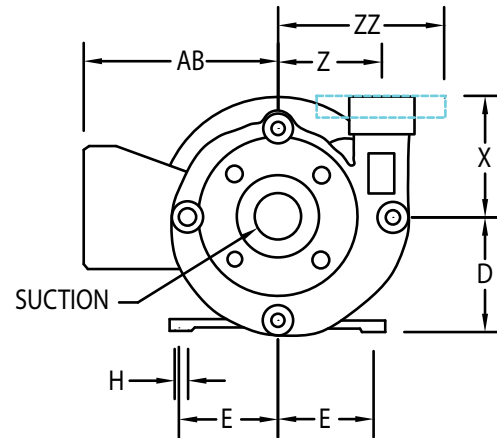
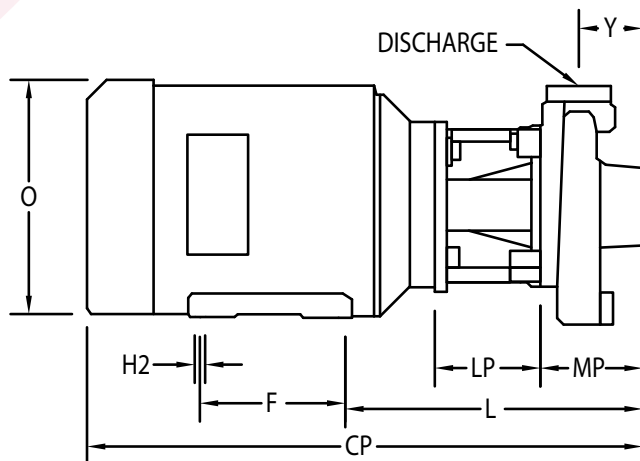

IL1422

STANDARD FEATURES

- Stainless steel and cast iron construction
- Buna N or Viton® mechanical seal and o-rings depending on model
- Stainless steel hardware
- NEMA TEFC three phase motors
- Self-cleaning stainless steel impeller
- Discharge rotates in 90° Increments
- Max. working pressure to 150 PSI
- Max. temperature:
 - SS - 200° F Viton®
 - CI - 180° F Buna N

"C4" Series High Head Straight Centrifugal Pumps



- Investment cast 316 stainless steel construction with Viton seals or cast iron construction with Buna seals
- Discharge port rotates in 90° Increments
- Four front drain plugs
- Max. working pressure 150 PSI
- Max. temperature 200° F
- Max. flow 42 GPM
- Max. head 76 Ft. (33 PSI)
- High efficiency stainless steel closed impeller
- Totally enclosed fan cooled (TEFC) 56J motors
- 3/4 HP single and three phase 3450 RPM motors



C4 SERIES

F&W High Head Straight Centrifugal pumps are designed for continuous-duty OEM, Industrial/Commercial and processing applications including circulation, liquid transfer, heating and cooling and pressure boosting. Applications include, but are not limited to cooling towers and chemical transfer.

These heavy duty high pressure pumps are available in a variety of construction and seal materials to meet your specification.

All models feature Type 21 mechanical seals and O-rings. Pull-from-the-rear design for easy servicing without disturbing any piping. High efficiency investment cast stainless steel impellers maximize performance.

PERFORMANCE

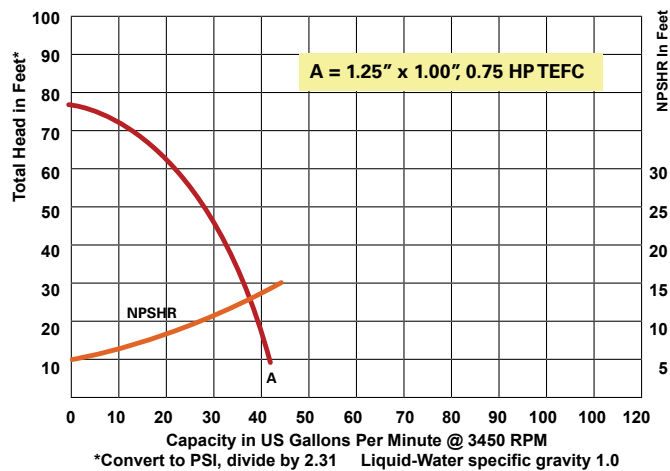

"C4" Series High Head Straight Centrifugal Pumps

PUMP DIMENSIONAL & SPECIFICATION CHART

CI No.	SS No.	HP	PH	Encl.	Voltage @ 60 Hz ±10%	Full Load Amps	SUC*	DIS*	CP**	D	E	F	H1	H2	L	OP	T1	T2	W1	W2	X	Y	Z	Ship Wt. Lbs.
C43A071T	C43S071T	3/4	1	TEFC	115/230	9/5	1-1/4"	1"	16.3	3.5	2.44	3.00	0.88	0.3	7.3	8.2	3.7	4.7	3.5	4.4	4.7	2.1	3.35	46
C43A073T	C43S073T	3/4	3	TEFC	230/460	3/2	1-1/4"	1"	14.2	3.5	2.44	3.00	0.88	0.3	7.3	8.2	3.7	4.7	3.5	4.4	4.7	2.1	3.35	44

(*) Standard NPT (female) pipe thread.

(**) This dimension may vary due to motor manufacturer's specifications

(+) 3-Phase motors can also operate on 50 Hz. (This will change the Full Load Amps, Service Factor and RPM)

NOTE: Dimensions have a tolerance of ± 1/8"

NOTE: Electric supply for ALL motors must be within ± 10% of nameplate voltage rating (ex. 230V ± 10% = 207 to 253)

CI = Cast Iron Construction with SS Impeller and Buna N Seals, Max. Temperature 180° F

SS = All 316 Stainless Steel Construction with Viton® Seals, Max. Temperature 200° F

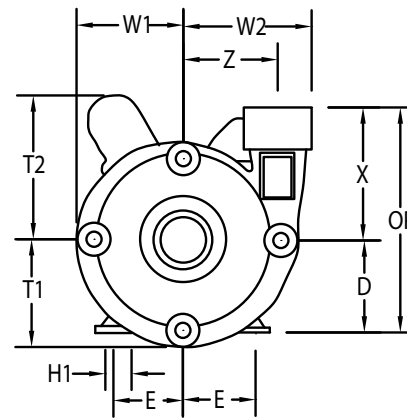
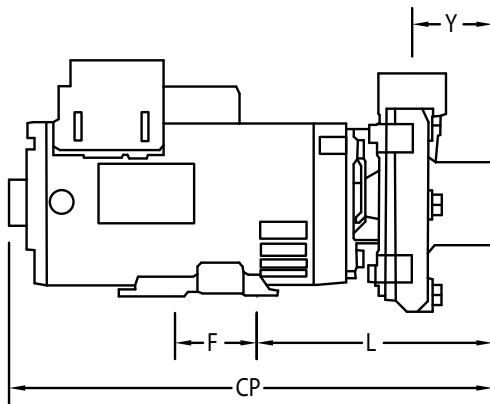

IL1424

STANDARD FEATURES

- 316 investment cast stainless steel with Viton seal
- Cast iron construction with Buna seals
- Stainless steel hardware
- NEMA 56J TEFC single and three phase 3450 RPM motors
- Stainless steel motor shaft
- NEMA base mounted motors
- High efficiency stainless steel closed impeller
- Discharge rotates in 90° increments
- Max. working pressure to 150 PSI
- Max. temperature:
SS - (Viton®) 200° F
CI - (Buna N) 180° F

"C6" Series Stainless Steel Straight Centrifugal Pumps



- 304 stainless steel construction
- Viton® mechanical seal and o-ring
- Investment cast stainless steel impeller
- High head and high volume models
- Max. working pressure 150 PSI
- Max. temperature 200° F
- Max. flow 156 GPM
- Max. head 82 Ft. (35 PSI)
- Chemical resistant design
- Discharge port rotates in 90° increments
- 56J frame totally enclosed fan cooled (TEFC) motors



C6 SERIES

Flint & Walling Stainless Steel Straight Centrifugal pumps are designed for continuous duty high flow and high pressure applications including liquid transfer, cooling, pressure boosting, circulating and applications requiring contaminant free pumping.

Constructed of rugged deep drawn 304 stainless steel for durability and corrosion resistance. Investment cast stainless steel closed impellers for enhanced performance and high efficiencies.

All models include Viton® Type 21 mechanical seals and O-rings which offer a broad range of chemical compatibility and can be used for highly corrosive liquids. Cast iron motor adapter provides a positive and rigid mounting to motor.

PERFORMANCE

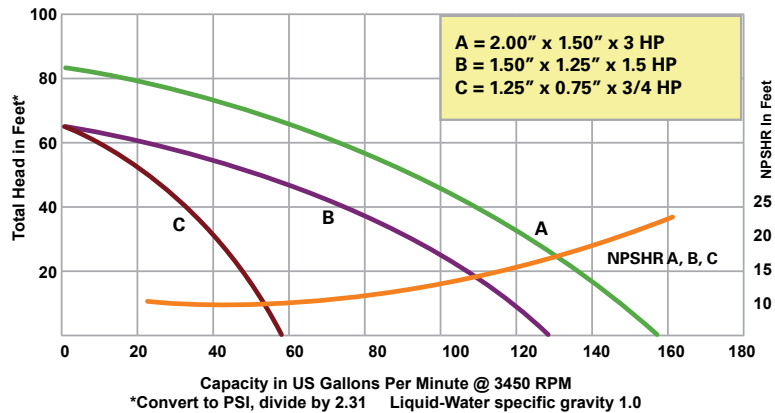

"C6" Series Stainless Steel Straight Centrifugal Pumps

PUMP DIMENSIONAL & SPECIFICATION CHART

High Volume Models Dimensional & Specification Chart

Model No.	Curve	HP	PH	Encl	Voltage @ 60 Hz $\pm 10\%$	Full Load Amp	SUC*	DIS*	CP**	AB**	L	OP	T	T1**	X	Y	Z	Ship Wt. Lbs.
C63071T	C	3/4	1	TEFC	115/230	9/5	1-1/4	3/4	14.0	4.9	6.5	7.9	3.4	N/A	4.4	2.2	4.1	38
C63073T	C	3/4	3	TEFC	230/460	3/2	1-1/4	3/4	13.4	4.9	6.5	7.9	3.4	N/A	4.4	2.2	4.1	31
C64151T	B	1.5	1	TEFC	115/230	18/9	1-1/2	1-1/4	14.8	4.6	6.1	7.9	3.4	N/A	4.4	1.8	4.0	50
C64153T	B	1.5	3	TEFC	230/460	5/3	1-1/2	1-1/4	14.0	4.9	6.1	7.9	3.4	N/A	4.4	1.8	4.0	39
C65301T	A	3	1	TEFC	230	16	2	1-1/2	16.2	4.9	6.2	7.9	3.4	N/A	4.4	1.9	4.0	57
C65303T	A	3	3	TEFC	230/460	8/4	2	1-1/2	15.7	4.9	6.2	7.9	3.4	N/A	4.4	1.9	4.0	54

(*) Standard NPT (female) pipe thread.

(**) This dimension may vary due to motor manufacturer's specifications.

(+) 3-Phase motors can also operate on 50 Hz. (This will change Full Load Amps, Service Factor and RPM)

NOTE: Dimensions have a tolerance of $\pm 1/8"$

NOTE: Electric supply for ALL motors must be within $\pm 10\%$ of nameplate voltage rating (ex. 230V $\pm 10\%$ = 207 to 253)

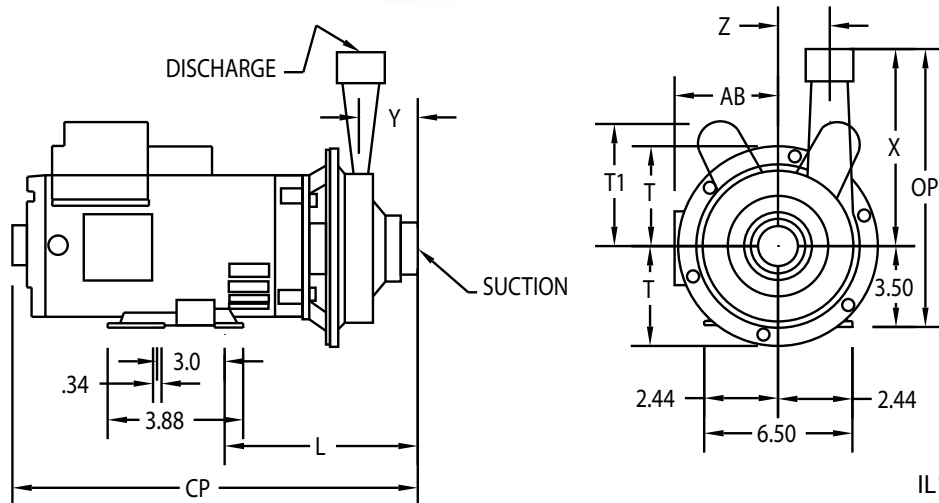

IL1425

STANDARD FEATURES

- 304 stainless steel construction
- Investment cast stainless steel impeller
- Viton® mechanical seal and o-ring
- Cast iron motor adapter provides rigid mounting
- NEMA 56J TEFC single & three phase motors
- Stainless steel hardware
- Stainless steel motor shaft
- Max. working pressure up to 150 PSI
- Max. temperature 200° F

"SPA" Series Sprinkler/Booster Pumps



- Cast iron construction with investment cast 316 stainless steel impeller
- Buna-N mechanical seal and o-ring
- 2" NPT port sizes
- Maximum working pressure 150 PSI
- Maximum temperature 180° F
- Maximum flow 157 GPM
- Maximum head 180 Ft.
- Self-priming to 20 Ft.
- Removable dual volute design
- 5 and 7-1/2 HP single or three phase TEFC motors

F&W Sprinkler/Booster pumps feature Investment Cast 316 Stainless Steel closed impellers for high efficiency and resistance against erosion caused by abrasive particles. Applications include, but are not limited to amusement parks, golf courses, industrial, fountains and water parks.

All models self-prime to 20 ft. and feature dual volute design to reduce radial load on motor and a built-in check valve to insure fast priming after initial liquid is added to the pump. Cast iron construction provides durability and low maintenance. Easy cleanout design includes replaceable dual volute and casing o-ring for servicing. Type 21 mechanical seals handle maximum working pressure to 150 PSI.

Pumps are available in 5 and 7-1/2 HP with Totally Enclosed Fan Cooled (TEFC) motors.

PERFORMANCE

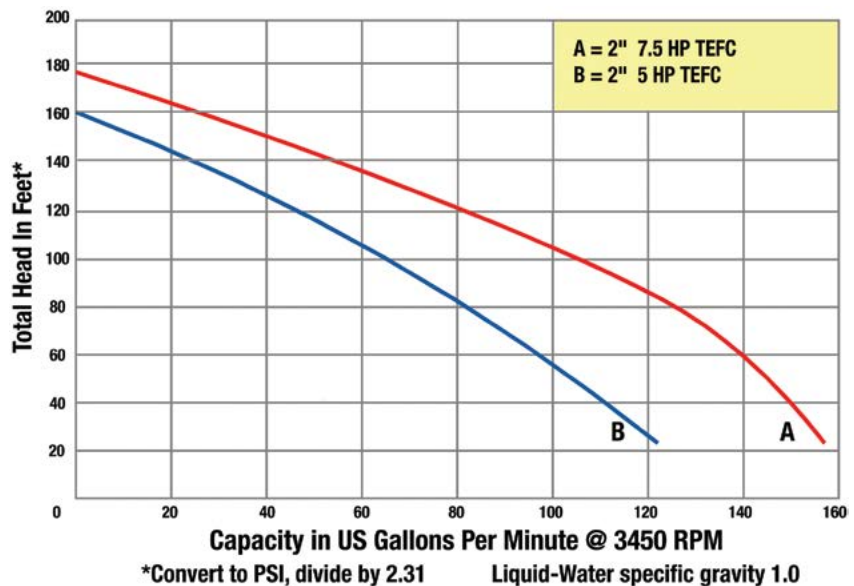

PUMP DIMENSIONAL & SPECIFICATION CHART

Model	Curve	HP	PH	ENC	Voltage @ 60 Hz	Full Load Amp	S.F. Amps	SUC*	DIS*	CP**	D	E	F	H	L	W1	W2	O	Y	Ship Wt. Lbs.
SPA50A1	B	5	1	TEFC	230	20	23	2	2	27.4	5.2	3.7	5.5	0.4	15.9	8.6	5.0	10	3.1	146
SPA50A3	B	5	3	TEFC	230/460	13/7	15/8	2	2	27.9	5.2	3.7	5.5	0.4	15.9	8.6	5.0	10	3.1	130
SPA75A3	A	7-1/2	3	TEFC	230/460	19/10	22/11	2	2	21.8	5.2	3.7	5.5	0.4	15.9	8.6	5.0	10	3.1	134

(*) Standard NPT (female) pipe thread.

(**) This dimension may vary due to motor manufacturer's specifications

(+) 3-Phase motors can also operate on 50 Hz. (This will change the Full Load Amps, Service Factor and RPM)

NOTE: Dimensions have a tolerance of $\pm 1/8"$

NOTE: Electric supply for ALL motor must be within $\pm 10\%$ of nameplate voltage rating (ex. $230V \pm 10\% = 207$ to 253)

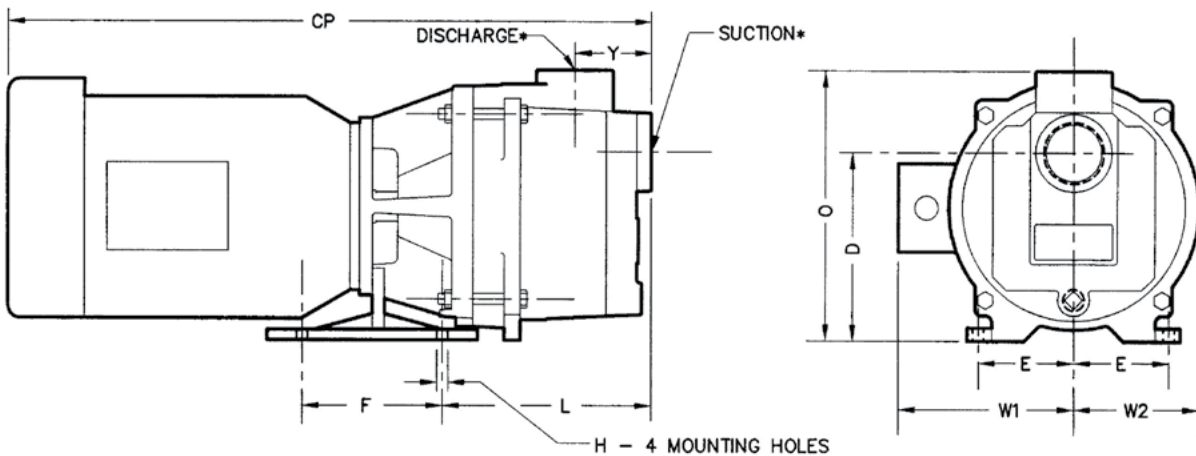

STANDARD FEATURES

- Cast iron construction
- Cast 316 stainless steel impellers
- Buna-N mechanical seal and o-ring
- TEFC JM frame motors
- Removable dual volute design
- Self-priming to 20 ft.
- Maximum working pressure to 150 PSI
- Maximum temperature 180° F

END SUCTION CENTRIFUGAL COMPOSITE CURVES

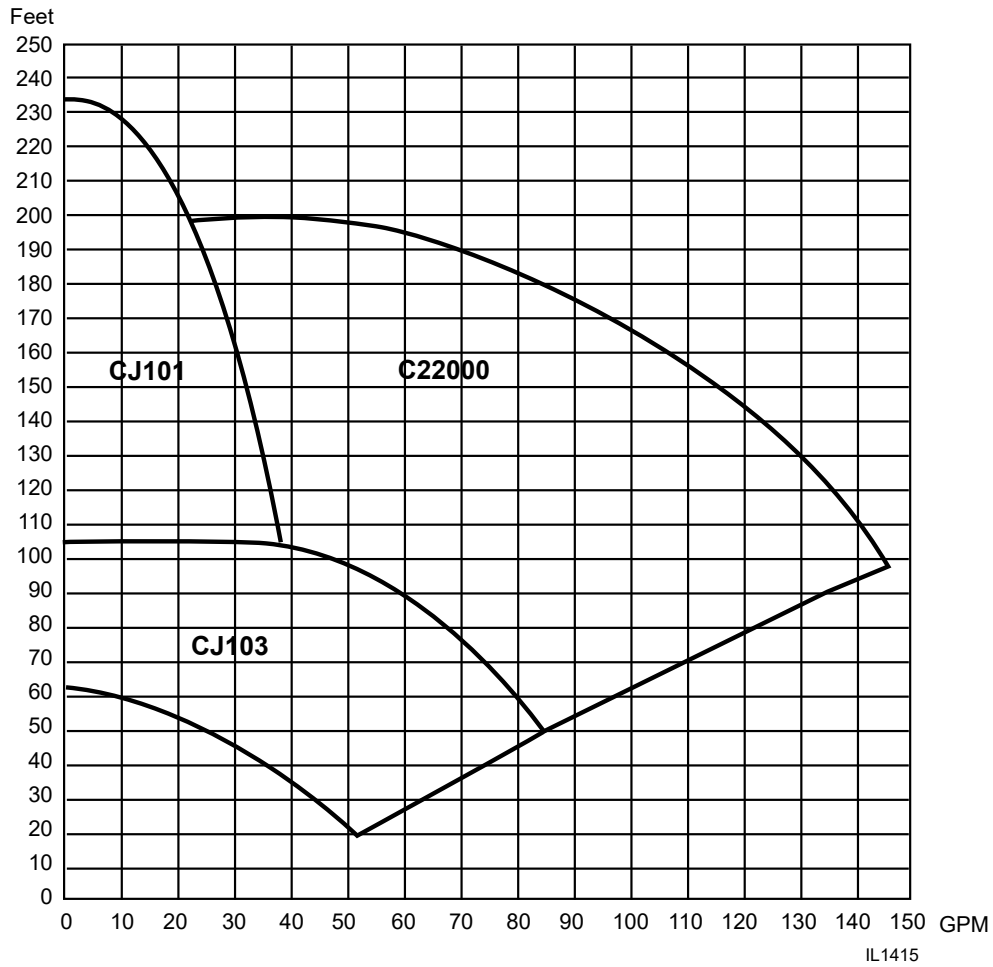

END SUCTION CENTRIFUGALS

CJ10303-1	1/3 HP Single Phase
3450 RPM	60 Hz
Impeller No. 130403	4.06 O.D.
Suction	1-1/2" NPT
Discharge	1-1/4" NPT
Max. Case Pressure, 100 PSI	
Liquid 1.0 Sp. Gr.	

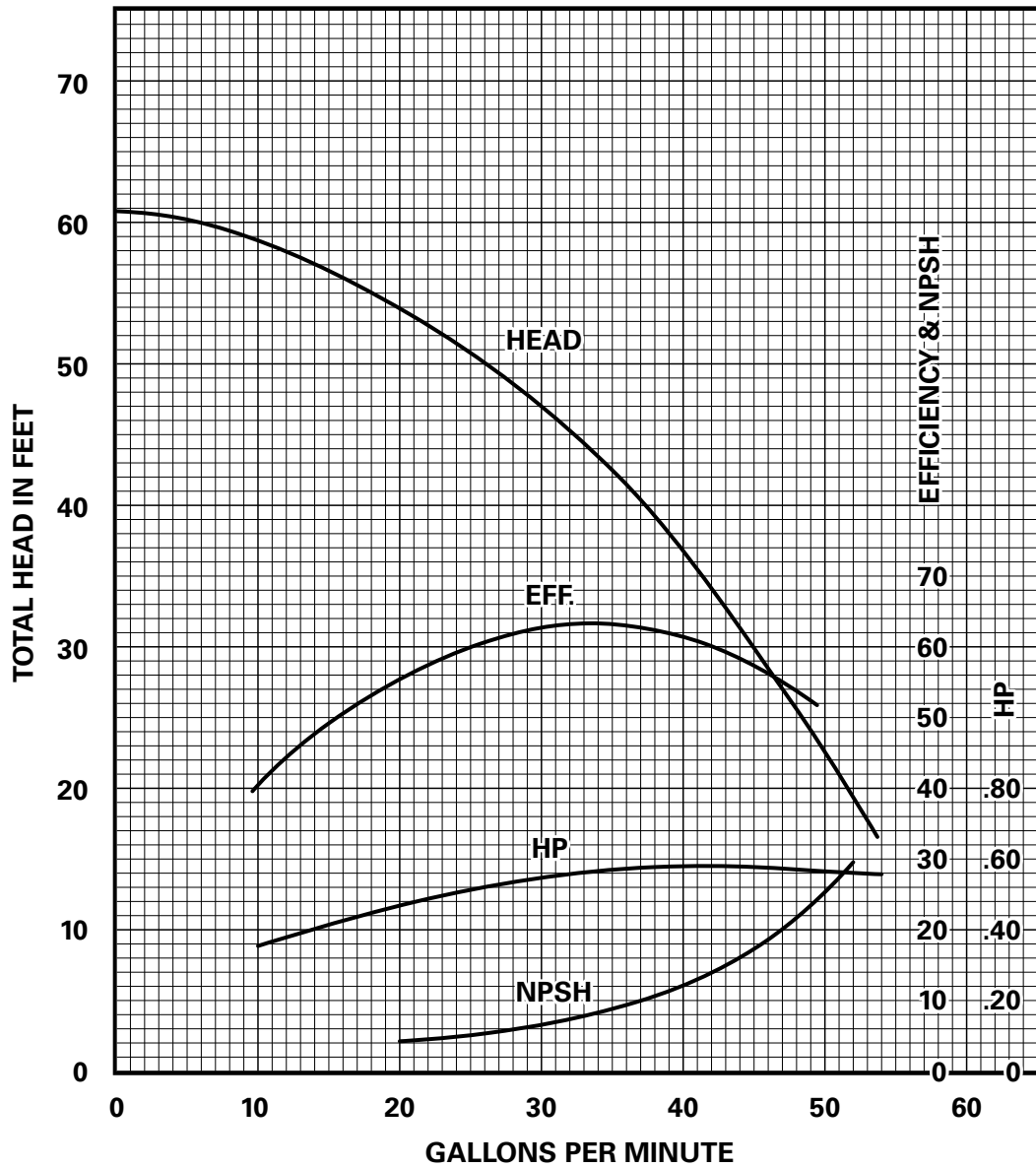

END SUCTION CENTRIFUGALS

CJ10305-1	1/2 HP Single Phase
CJ10305-3	1/2 HP Three Phase
3450 RPM	60 Hz
Impeller No. 126900	4.46 O.D.
Suction	1-1/2" NPT
Discharge	1-1/4" NPT
Max. Case Pressure,	100 PSI
Liquid	1.0 Sp. Gr.

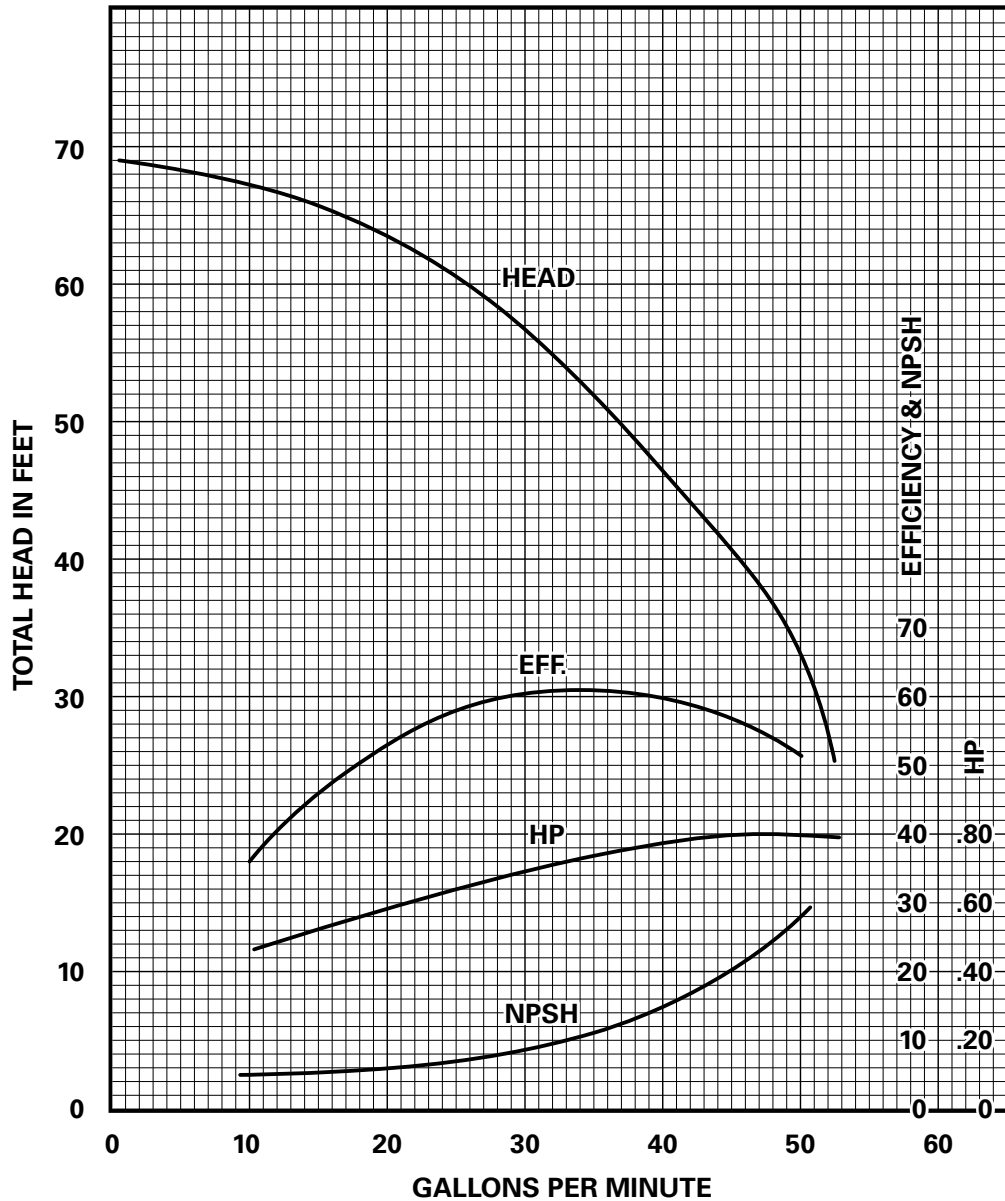

END SUCTION CENTRIFUGALS

CJ10307-1	3/4 HP Single Phase
CJ10307-3	3/4 HP Three Phase
3450 RPM	60 Hz
Impeller No. 127805	4.44 O.D.
Suction	1-1/2" NPT
Discharge	1-1/4" NPT
Max. Case Pressure,	100 PSI
Liquid	1.0 Sp. Gr.

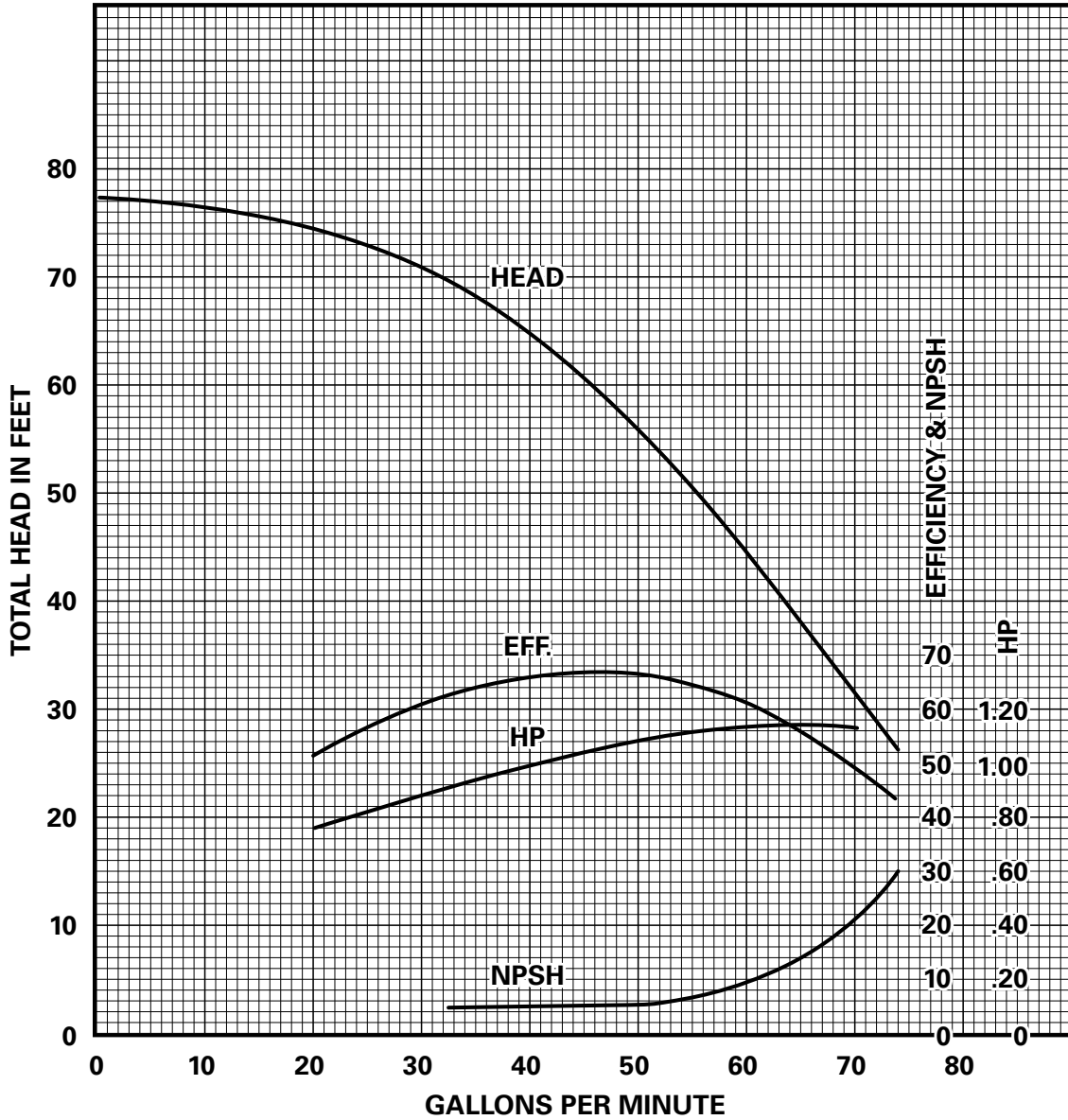

END SUCTION CENTRIFUGALS

CJ10310-1	1 HP Single Phase
CJ10310-3	1 HP Three Phase
3450 RPM	60 Hz
Impeller No. 127804 4.87 O.D.	
Suction	1-1/2" NPT
Discharge	1-1/4" NPT
Max. Case Pressure, 100 PSI	
Liquid 1.0 Sp. Gr.	

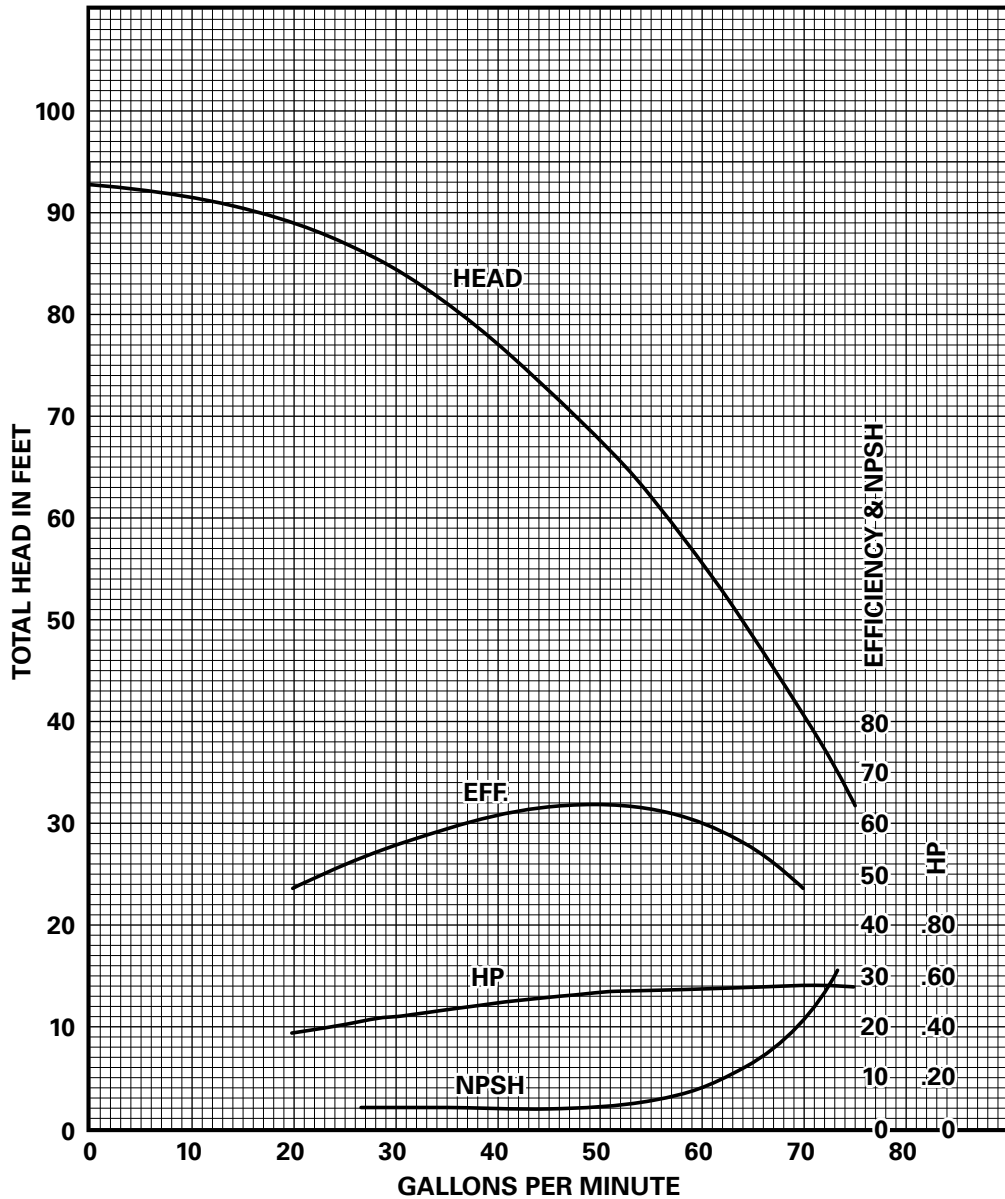

END SUCTION CENTRIFUGALS

CJ10315-1	1-1/2 HP Single Phase
CJ10315-3	1-1/2 HP Three Phase
3450 RPM	60 HZ
Impeller No. 127806 5.09 O.D.	
Suction	1-1/2" NPT
Discharge	1-1/4" NPT
Max. Case Pressure, 100 PSI	
Liquid 1.0 Sp. Gr.	

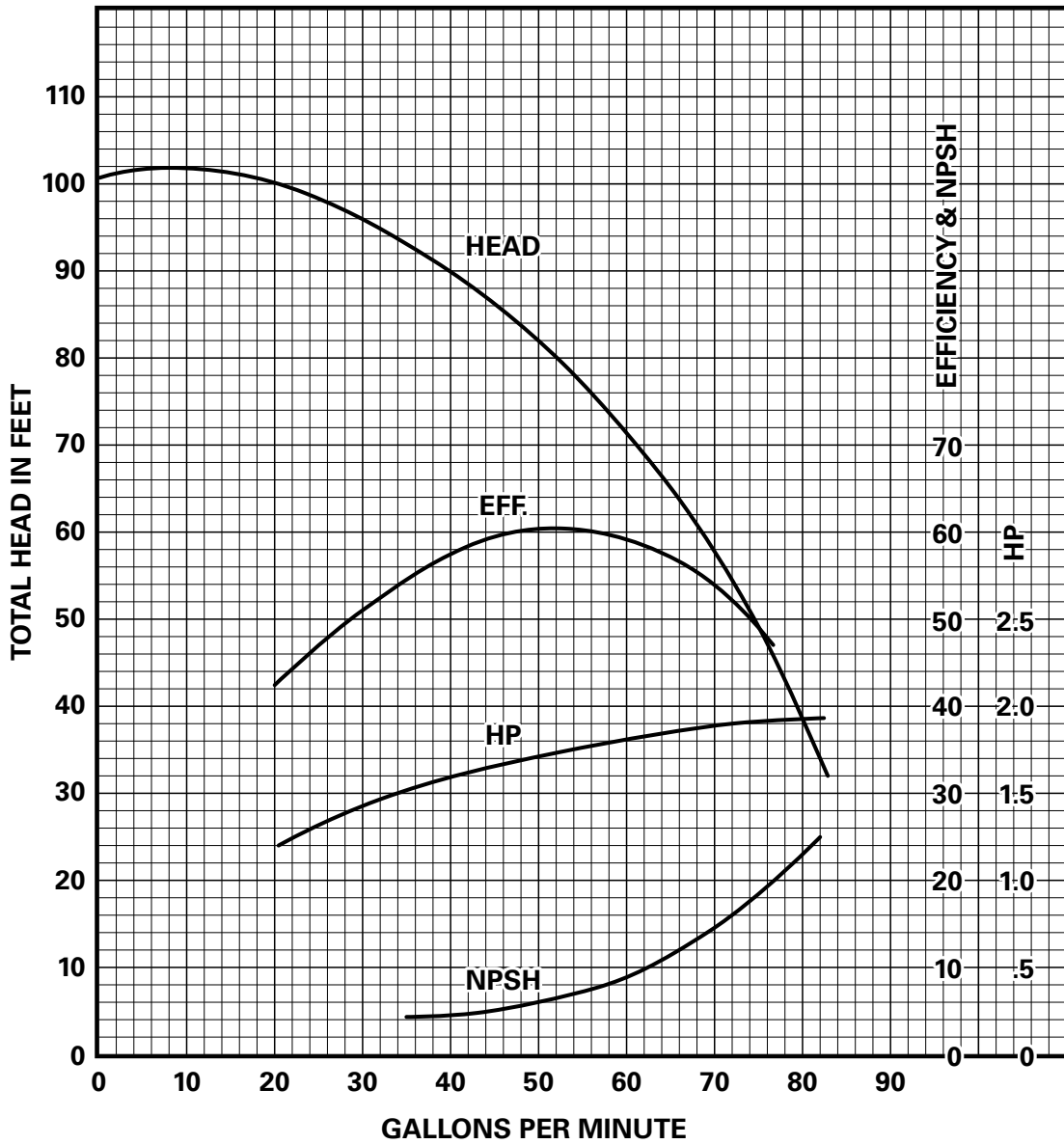

END SUCTION CENTRIFUGALS

CJ10320-1	3 HP Single Phase
CJ10320-3	2 HP Three Phase
3450 RPM	60 Hz
Impeller No. 127848	5.09 O.D.
Suction	1-1/2" NPT
Discharge	1-1/4" NPT
Max. Case Pressure,	100 PSI
Liquid	1.0 Sp. Gr.

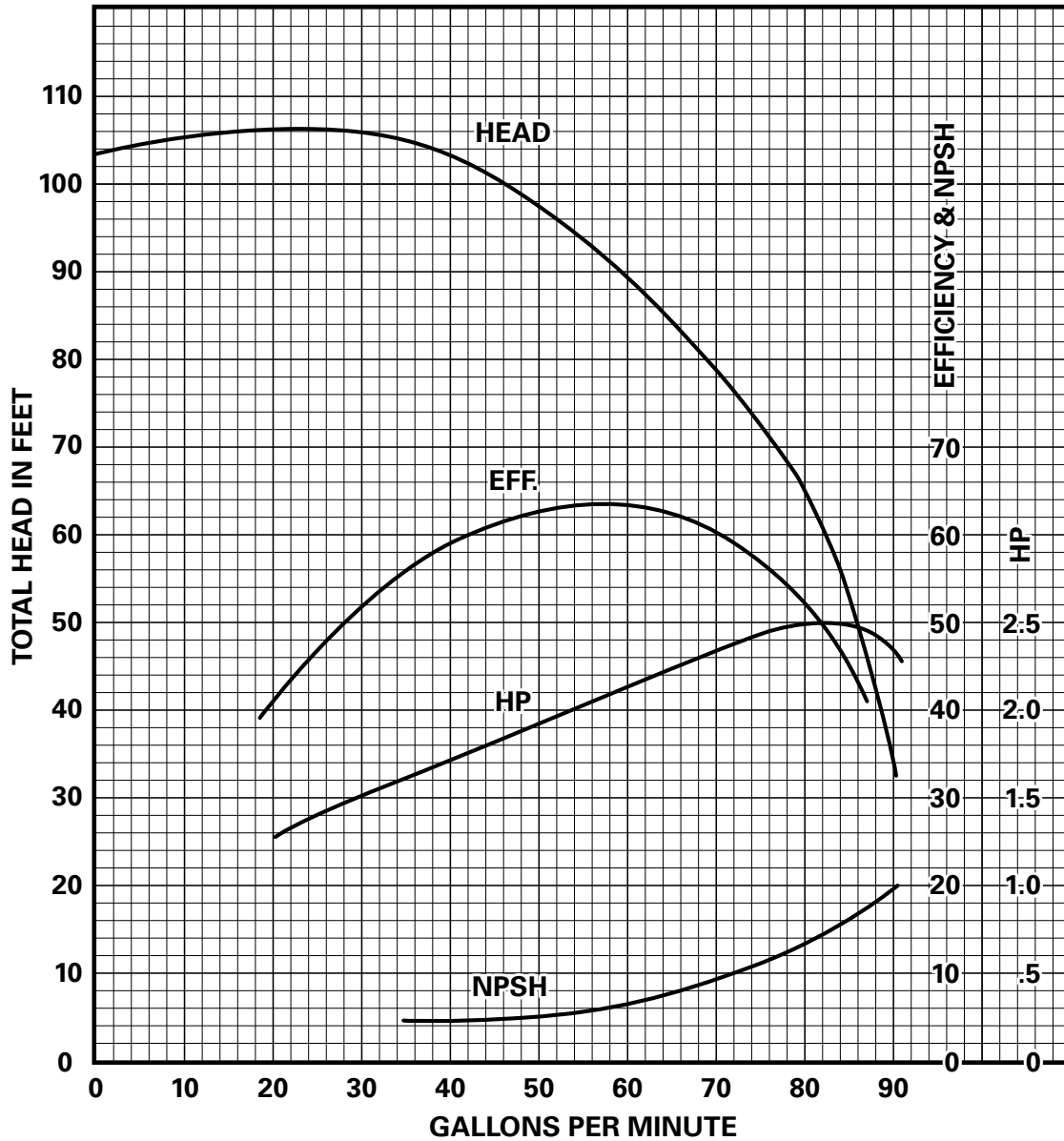

END SUCTION CENTRIFUGALS

CJ101B07-1	3/4 HP Single Phase
CJ101B07-3	3/4 HP Three Phase
	3450 RPM 60 Hz
	Impeller No. 135280 4.000 O.D. Brass
	Two Stage
Suction	1-1/2" NPT
Discharge	1-1/4" NPT
	Max. Case Pressure, 160 PSI
	Liquid 1.0 Sp. Gr.

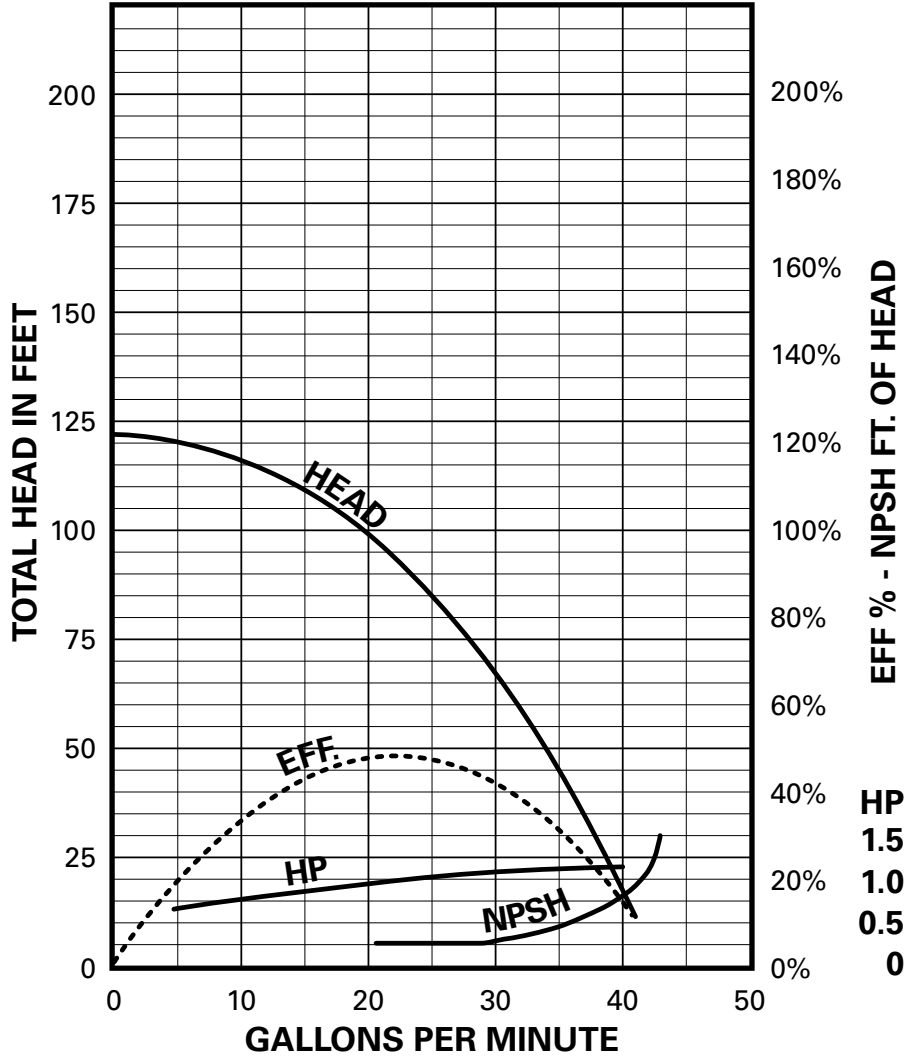

END SUCTION CENTRIFUGALS

CJ101B10-1 1 HP Single Phase
CJ101B10-3 1 HP Three Phase
3450 RPM 60 Hz
Impeller No. 135281 4.25 O.D. Brass
Two Stage
Suction 1-1/2" NPT
Discharge 1-1/4" NPT
Max. Case Pressure, 160 PSI
Liquid 1.0 Sp. Gr.

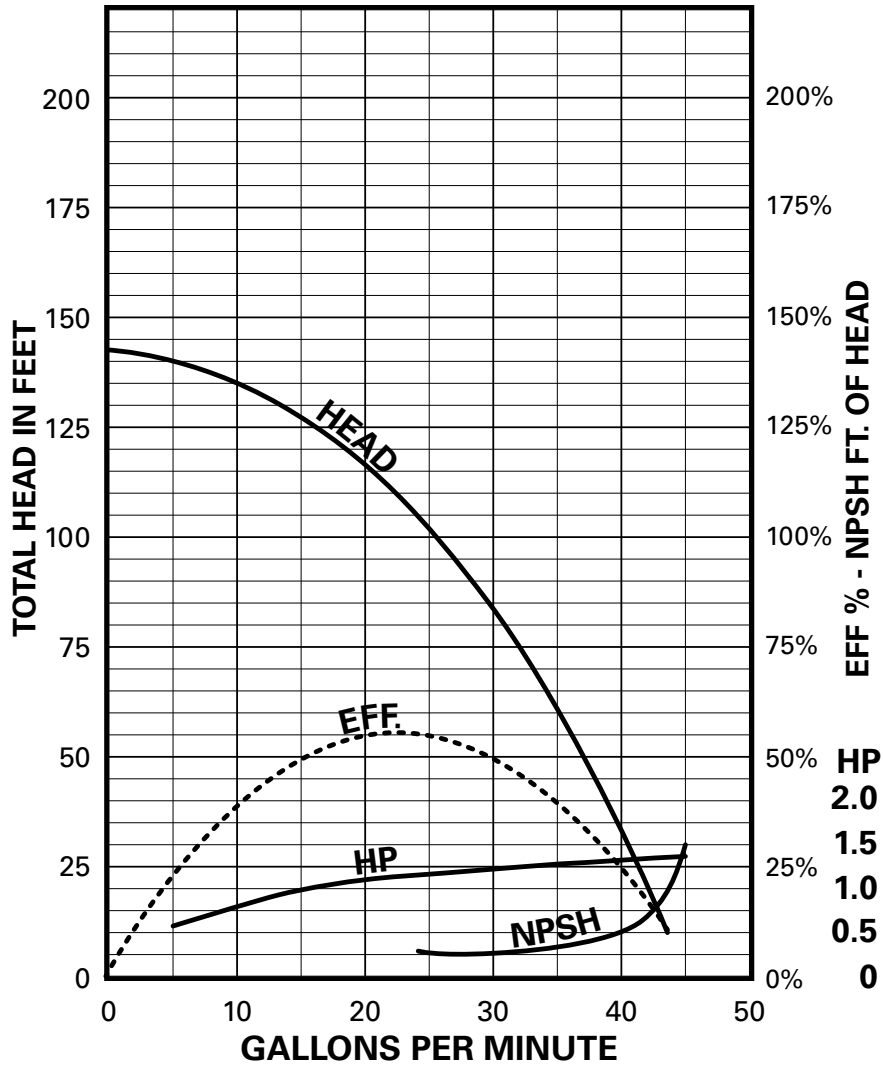

END SUCTION CENTRIFUGALS

CJ101B15-1	1-1/2 HP Single Phase
CJ101B15-3	1-1/2 HP Three Phase
3450 RPM	60 Hz
Impeller No. 126900 4.47 O.D. Brass	
Two Stage	
Suction	1-1/2" NPT
Discharge	1-1/4" NPT
Max. Case Pressure, 160 PSI	
Liquid 1.0 Sp. Gr.	

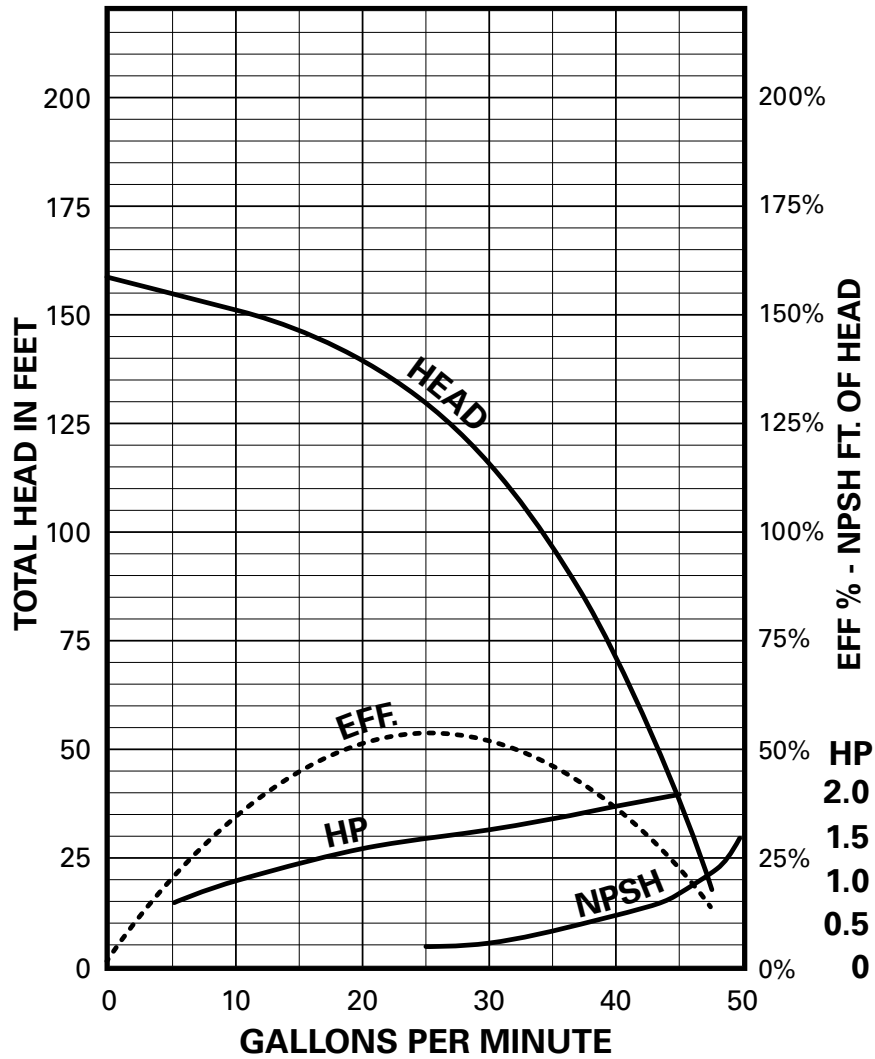

END SUCTION CENTRIFUGALS

CJ101B20-1 2 HP Single Phase
CJ101B20-3 2 HP Three Phase
3450 RPM 60 Hz
Impeller No. 126901 4.47 O.D. Brass
Two Stage
Suction 1-1/2" NPT
Discharge 1-1/4" NPT
Max. Case Pressure, 160 PSI
Liquid 1.0 Sp. Gr.

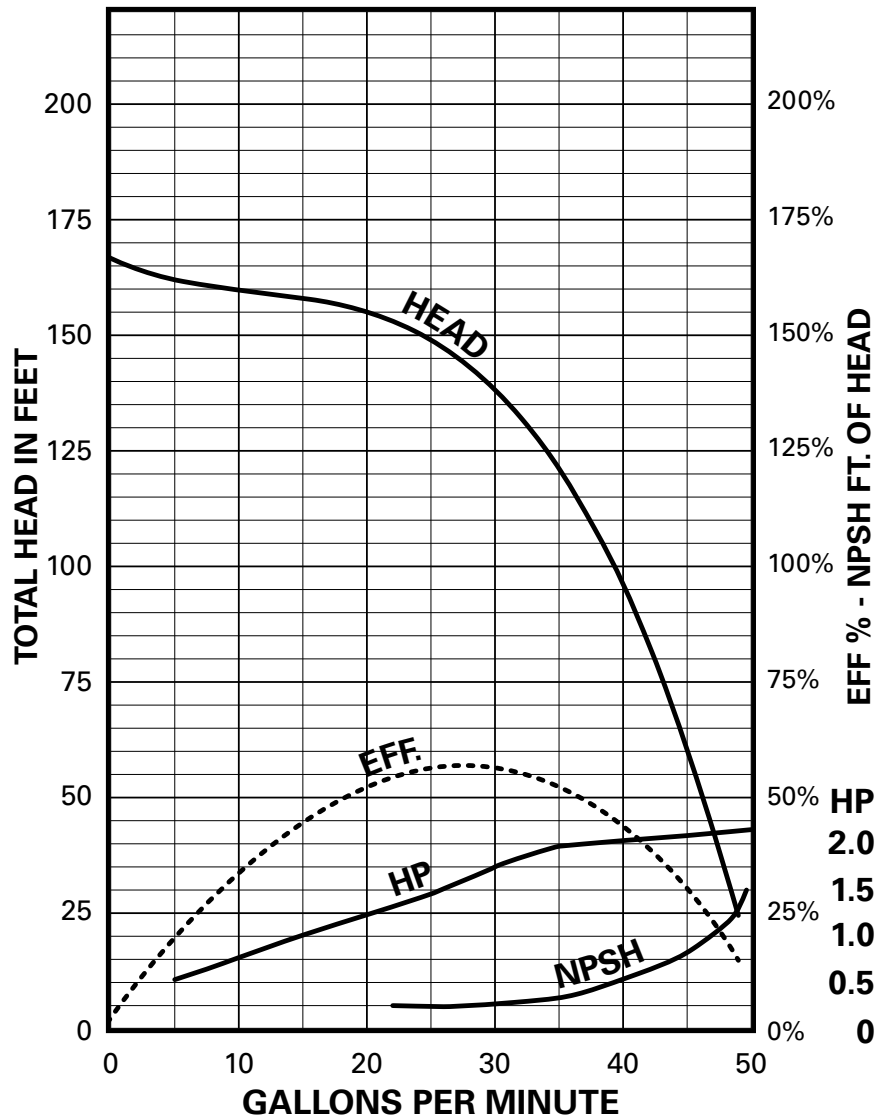

END SUCTION CENTRIFUGALS

CJ101C20-1 2 HP Single Phase
CJ101C20-3 2 HP Three Phase
3450 RPM 60 Hz
Impeller No. 139126 4.34 O.D. Brass
Three Stage
Suction 1-1/2" NPT
Discharge 1-1/4" NPT
Max. Case Pressure, 160 PSI
Liquid 1.0 Sp. Gr.

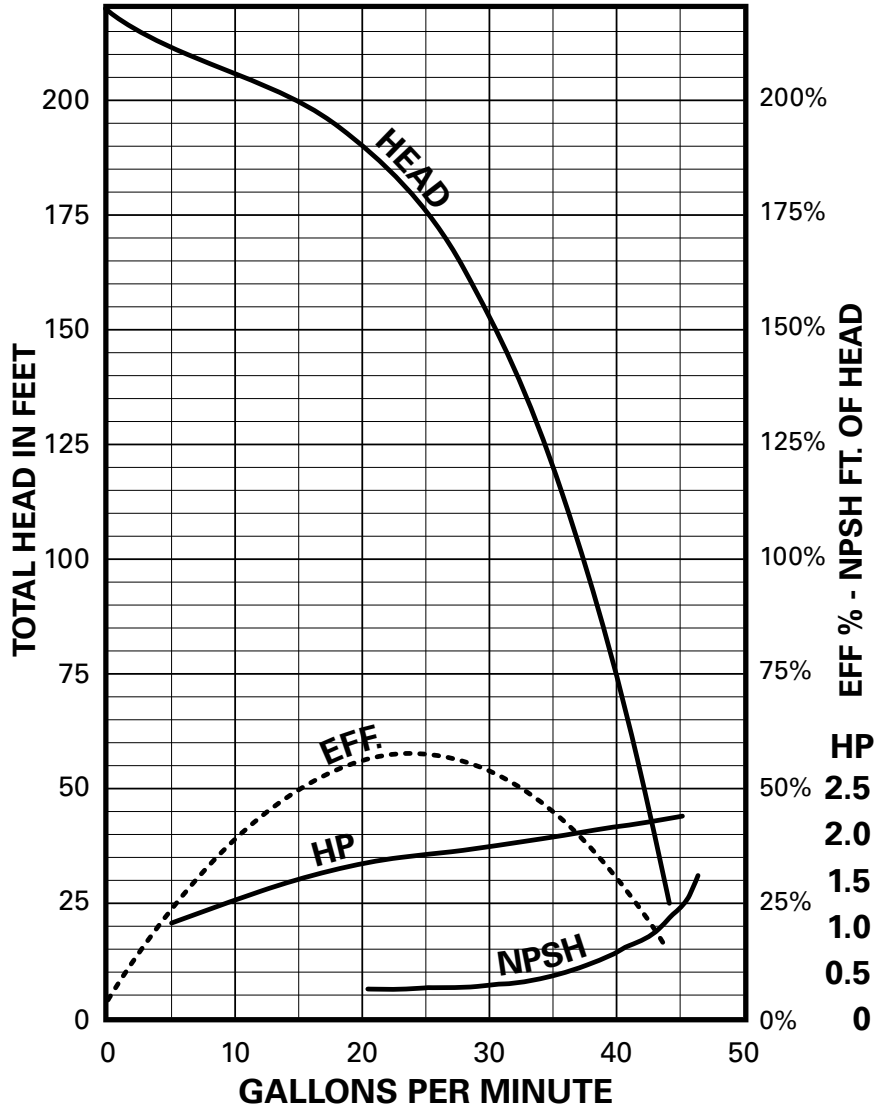

END SUCTION CENTRIFUGALS

CJ101C30-1 3 HP Single Phase
CJ101C30-3 3 HP Three Phase
3450 RPM 60 Hz
Impeller No. 136951 4.25 O.D. Brass
Three Stage
Suction 1-1/2" NPT
Discharge 1-1/4" NPT
Max. Case Pressure, 160 PSI
Liquid 1.0 Sp. Gr.

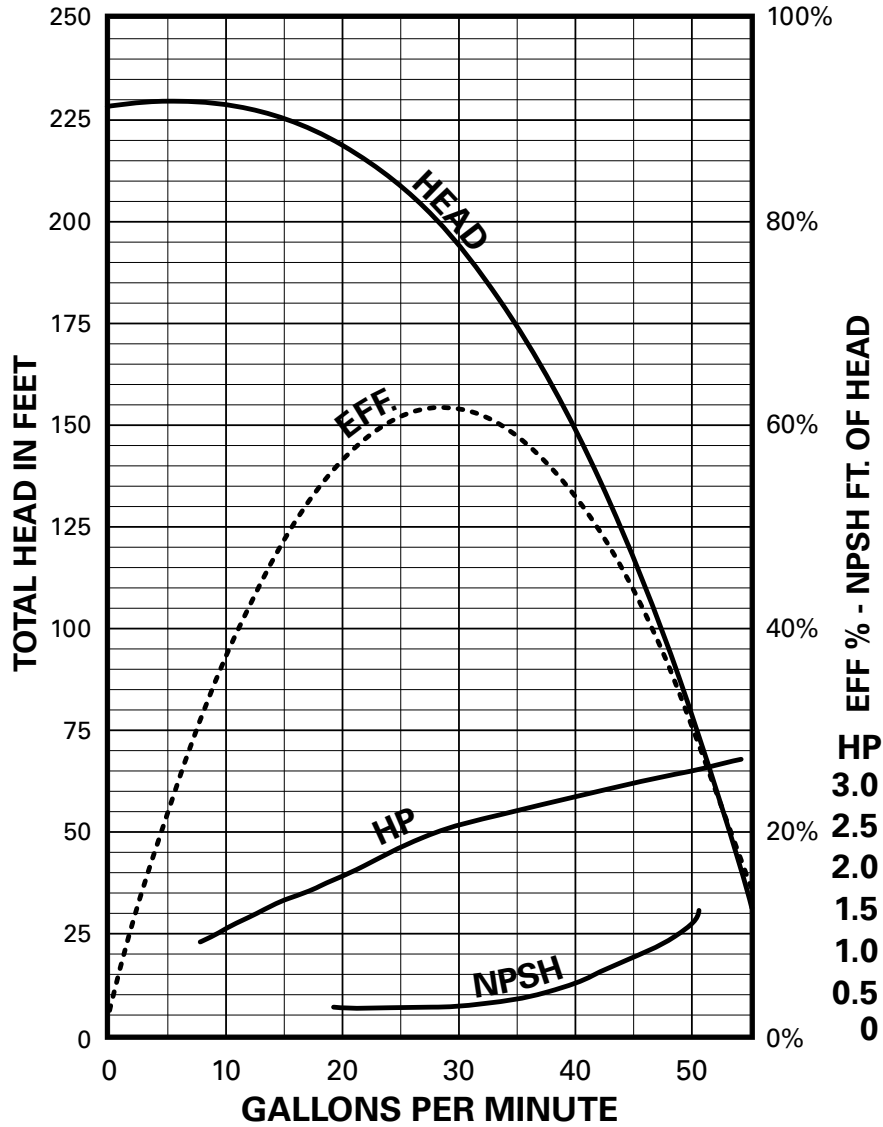

END SUCTION CENTRIFUGALS

CJ101P07-1 3/4 HP Single Phase
CJ101P07-3 3/4 HP Three Phase
3450 RPM 60 Hz
Impeller No. 133425 3.87 O.D. Celcon
Two Stage
Suction 1-1/2" NPT
Discharge 1-1/4" NPT
Max. Case Pressure, 160 PSI
Liquid 1.0 Sp. Gr.

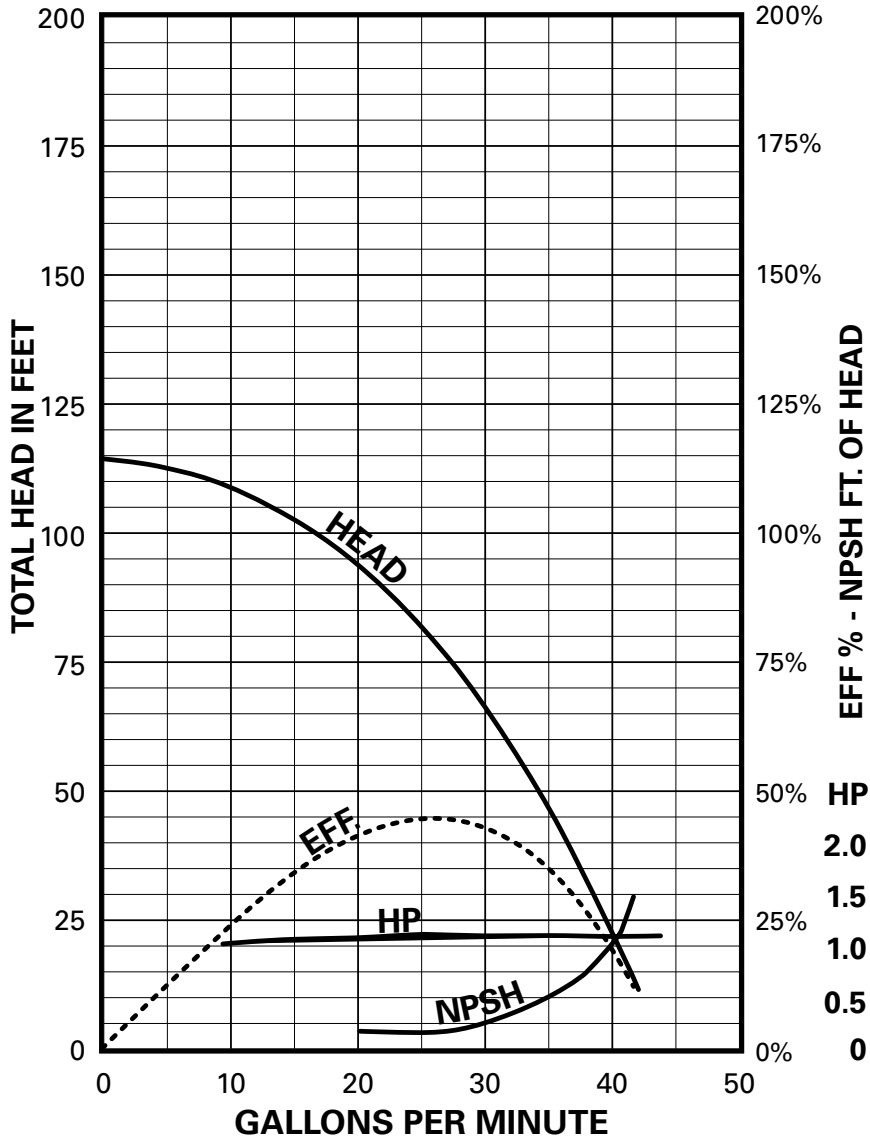

END SUCTION CENTRIFUGALS

CJ101P10-1	1 HP Single Phase
CJ101P10-3	1 HP Three Phase
3450 RPM	60 Hz
Impeller No. 133427 4.28 O.D. Celcon	
Two Stage	
Suction	1-1/2" NPT
Discharge	1-1/4" NPT
Max. Case Pressure, 160 PSI	
Liquid 1.0 Sp. Gr.	

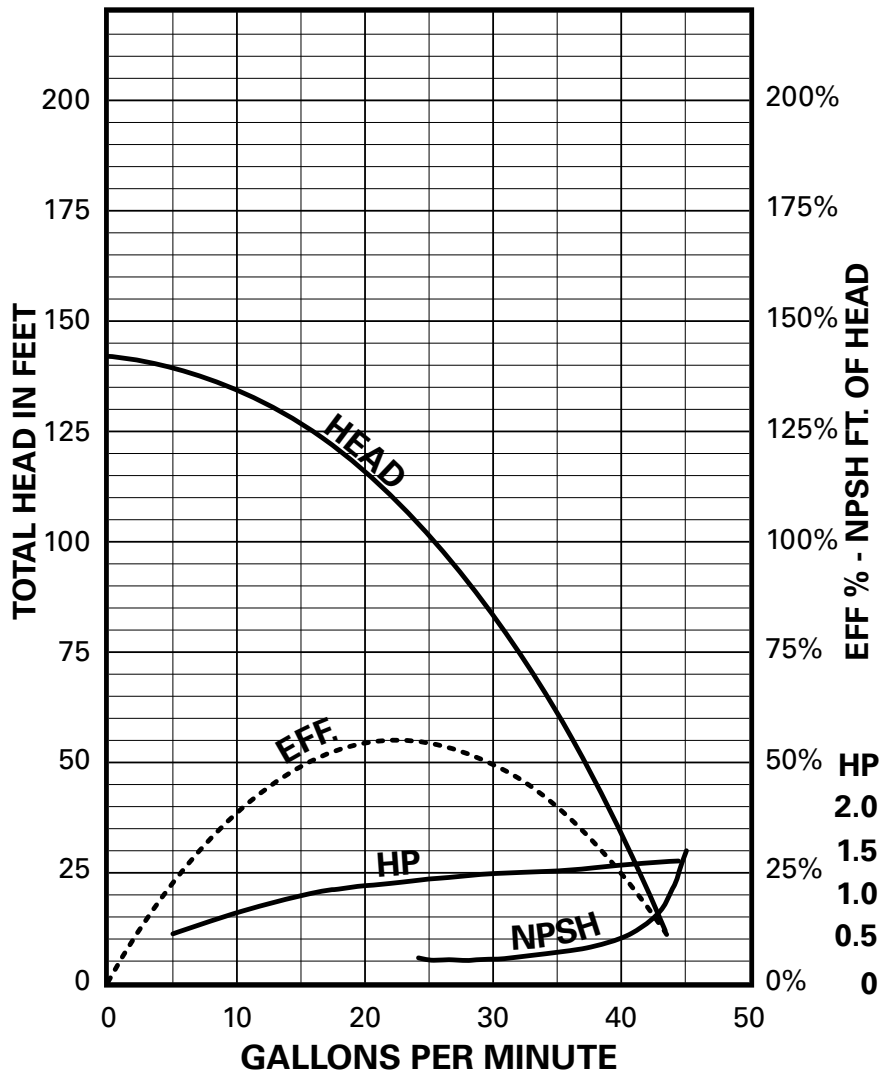

END SUCTION CENTRIFUGALS

CJ101P15-1 1-1/2 HP Single Phase
CJ101P15-3 1-1/2 HP Three Phase
3450 RPM 60 Hz
Impeller No. 139180 4.20 O.D. Celcon
Two Stage
Suction 1-1/2" NPT
Discharge 1-1/4" NPT
Max. Case Pressure, 160 PSI
Liquid 1.0 Sp. Gr.

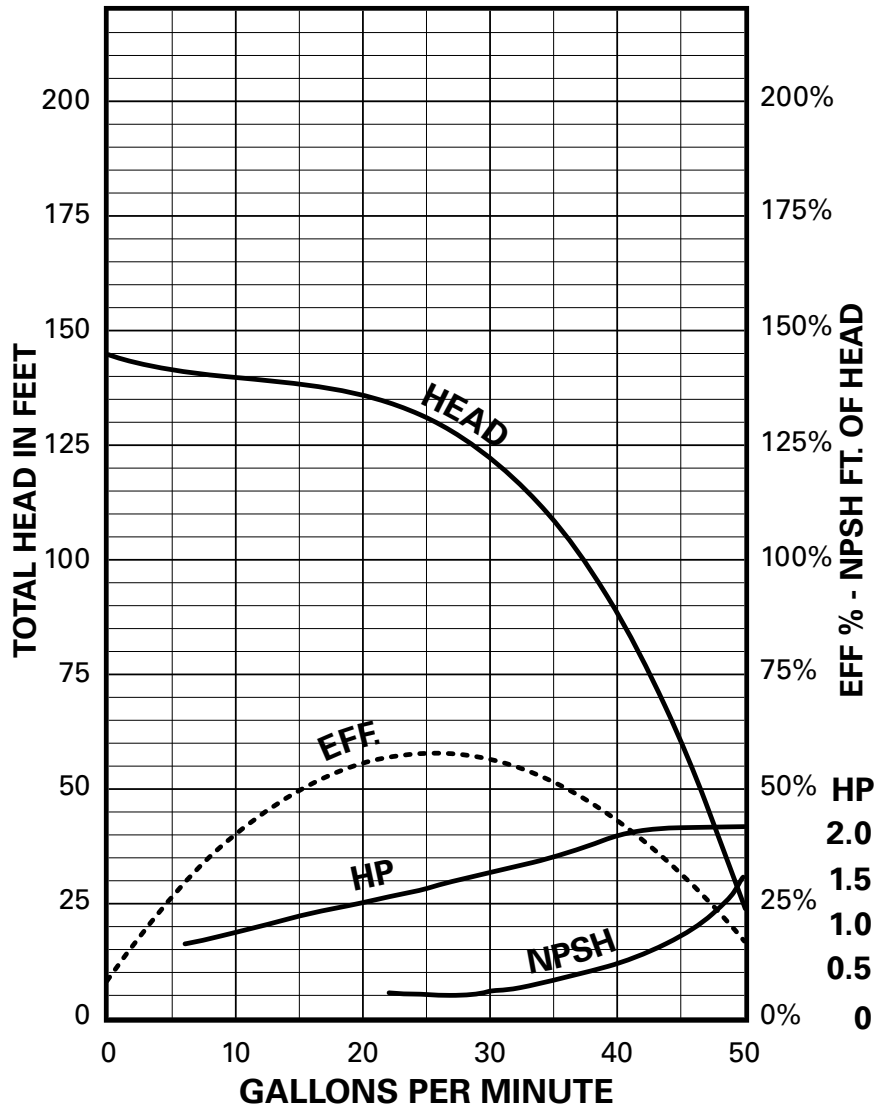

END SUCTION CENTRIFUGALS

CJ101P20-1	2.0 HP Single Phase
CJ101P20-3	2.0 HP Three Phase
3450 RPM	60 Hz
Impeller No. 128472 4.44 O.D. Celcon	
Two Stage	
Suction	1-1/2" NPT
Discharge	1-1/4" NPT
Max. Case Pressure, 160 PSI	
Liquid 1.0 Sp. Gr.	

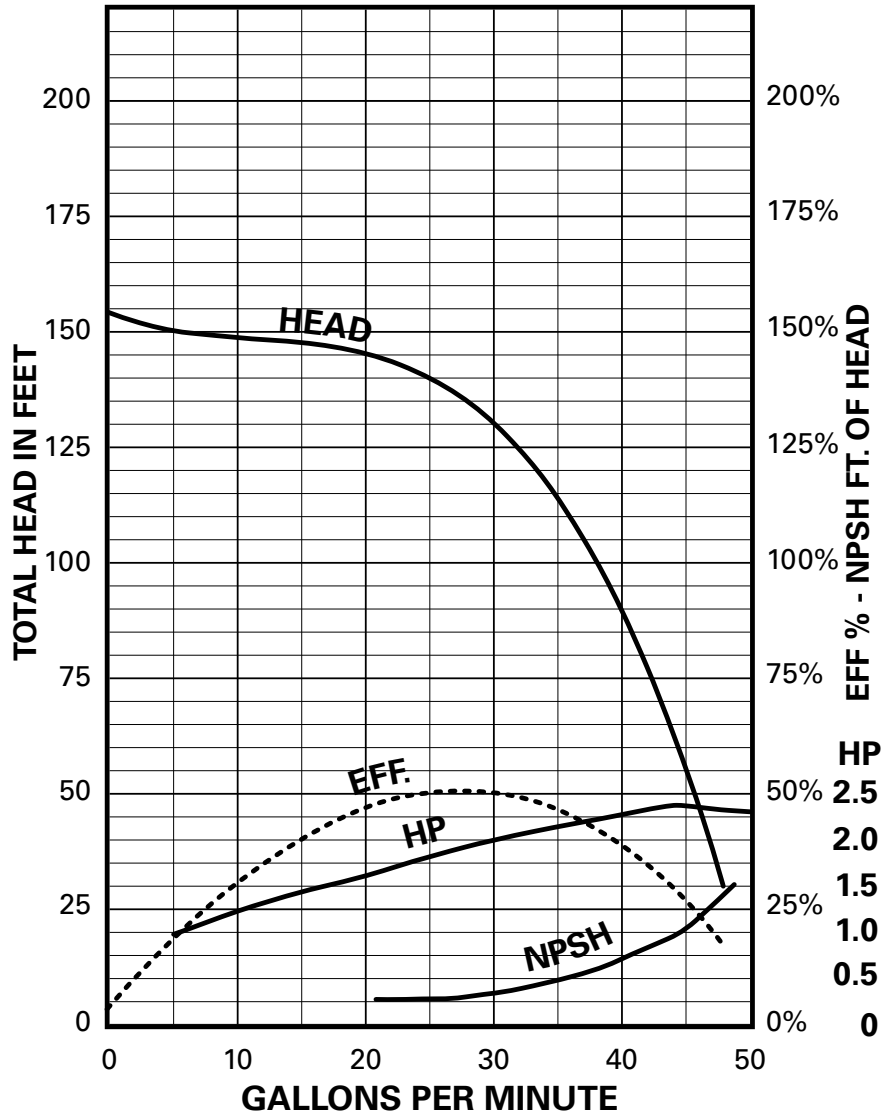

END SUCTION CENTRIFUGALS

CJ101D20-1 2 HP Single Phase
CJ101D20-3 2 HP Three Phase
3450 RPM 60 Hz
Impeller No. 133427 4.28 O.D. Celcon
Three Stage
Suction 1-1/2" NPT
Discharge 1-1/4" NPT
Max. Case Pressure, 160 PSI
Liquid 1.0 Sp. Gr.

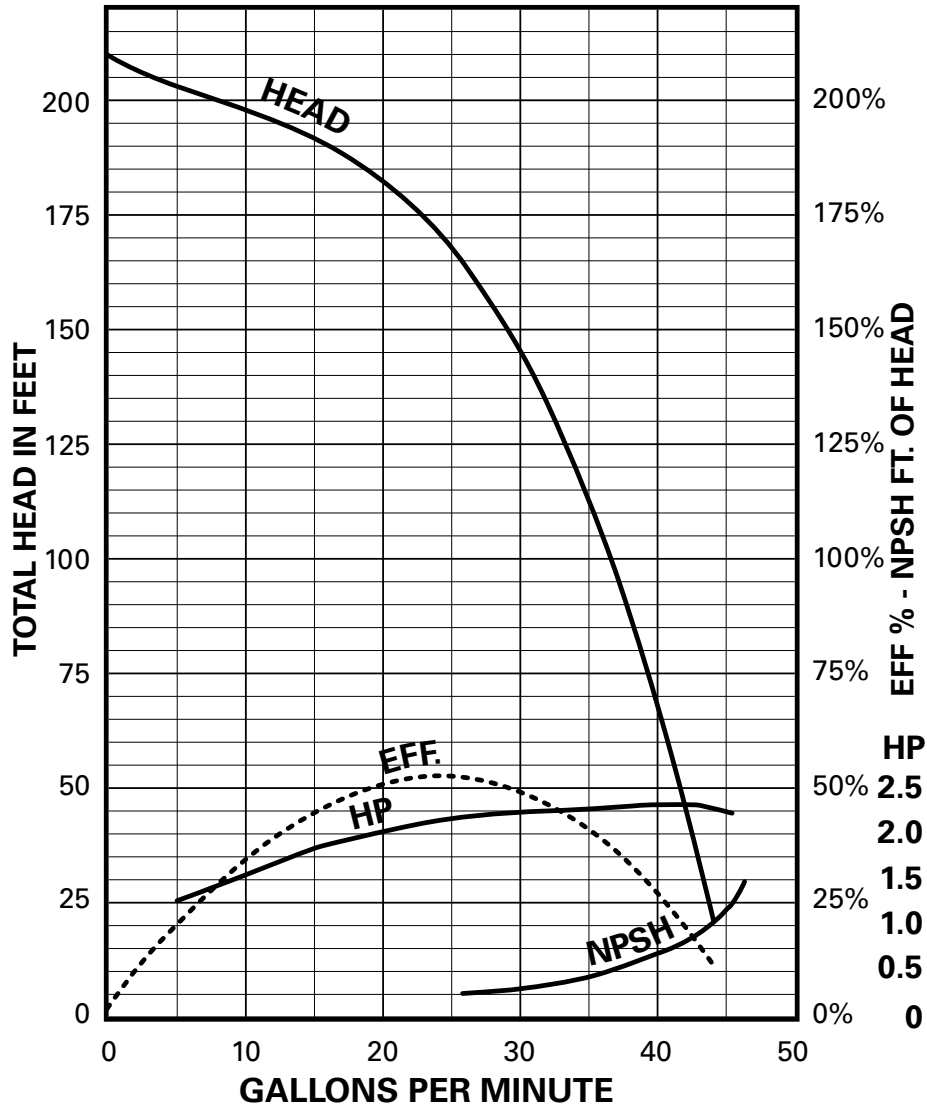

Pump Performance Curves



END SUCTION CENTRIFUGALS

CJ101D30-1 3 HP Single Phase
CJ101D30-3 3 HP Three Phase
3450 RPM 60 Hz
Impeller No. 139104 4.25 O.D. Celcon
Three Stage
Suction 1-1/2" NPT
Discharge 1-1/4" NPT
Max. Case Pressure, 160 PSI
Liquid 1.- Sp. Gr.

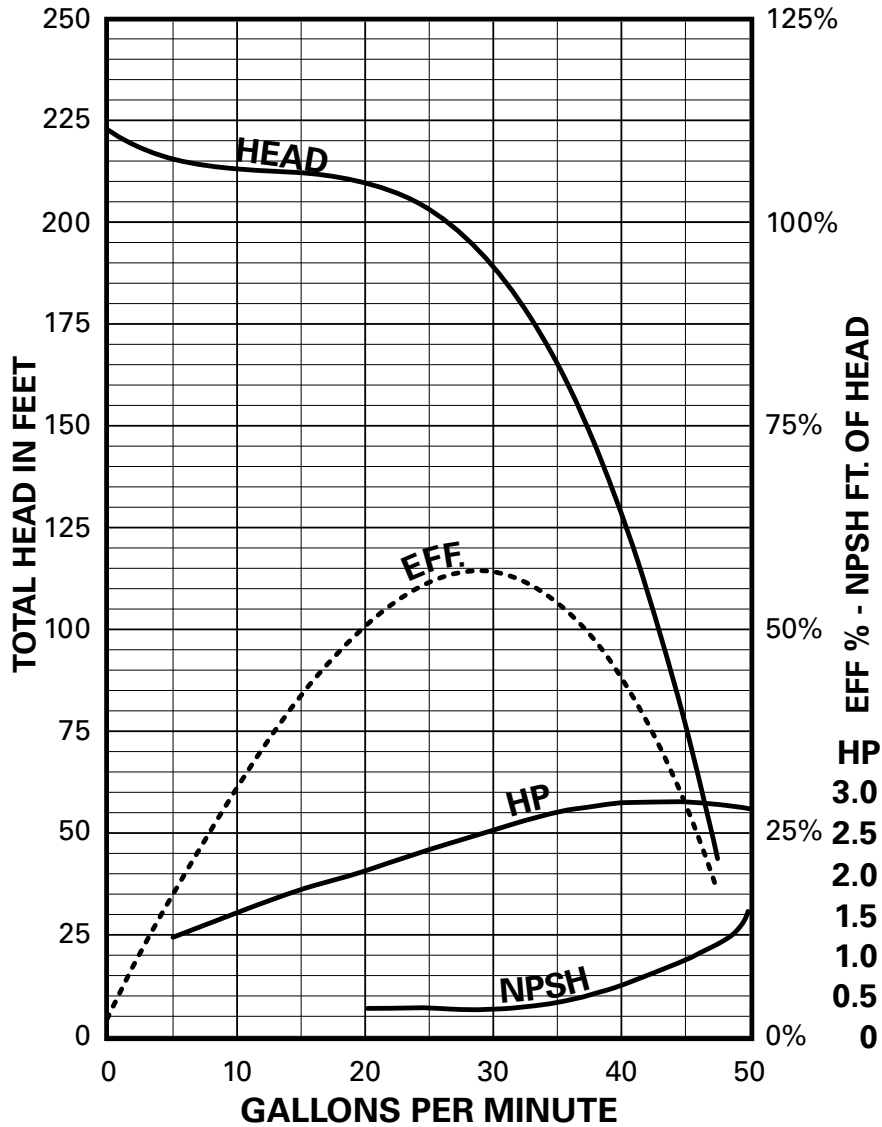

END SUCTION CENTRIFUGALS

C22251	5 HP Single Phase
C22253	5 HP Three Phase
3450 RPM	60 Hz
Two Stage	
Impeller No. 134974 & 134981 4.950 O.D.	
Suction	3" NPT
Discharge	2" NPT
Max. Case Pressure, 120 PSI	
Liquid 1.0 Sp. Gr.	

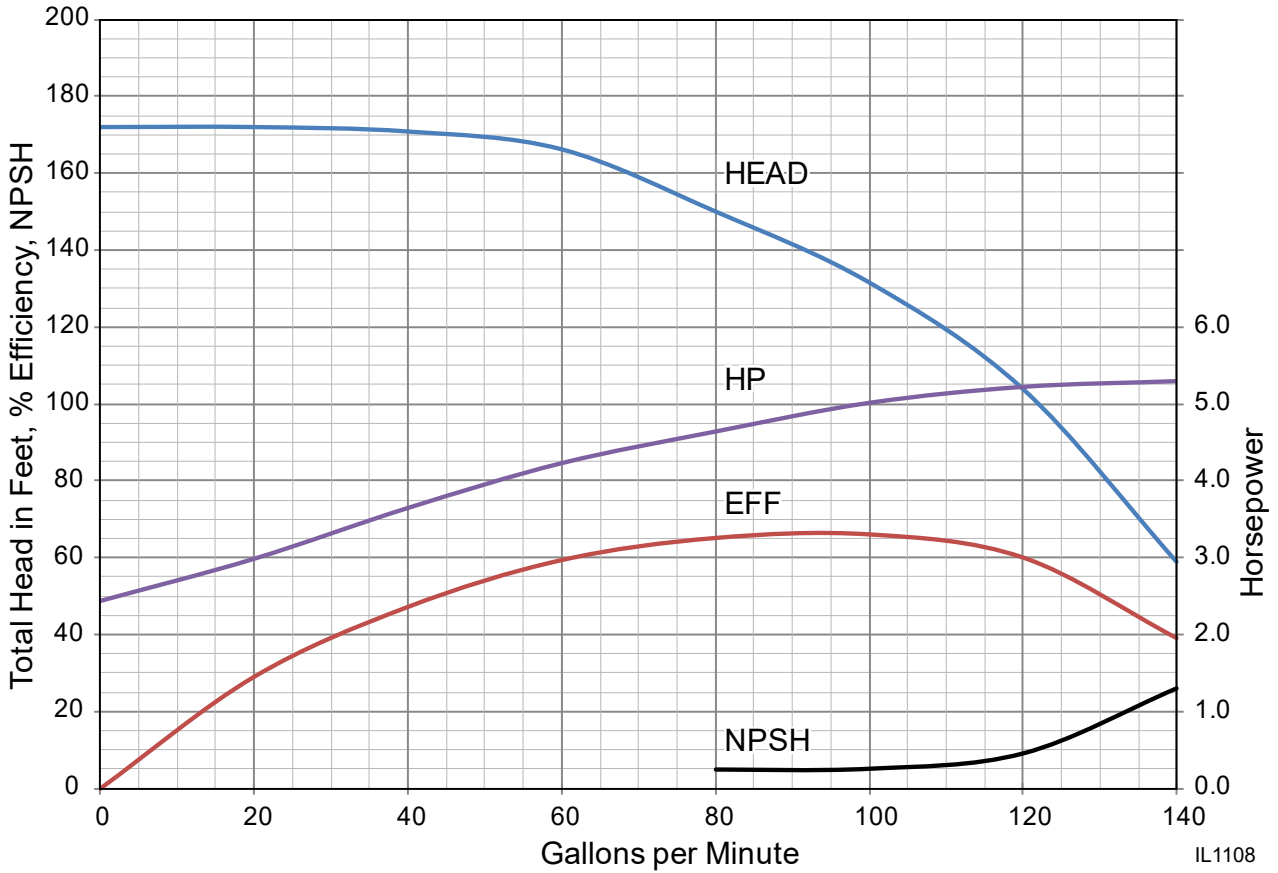

Pump Performance Curves



END SUCTION CENTRIFUGALS

C22273 7-1/2 HP Three Phase
3450 RPM 60 Hz
Two Stage
Impeller No. 134982 & 134975 5.25 O.D.
Suction 3" NPT
Discharge 2" NPT
Max. Case Pressure 120 PSI
Liquid 1.0 Sp. Gr.

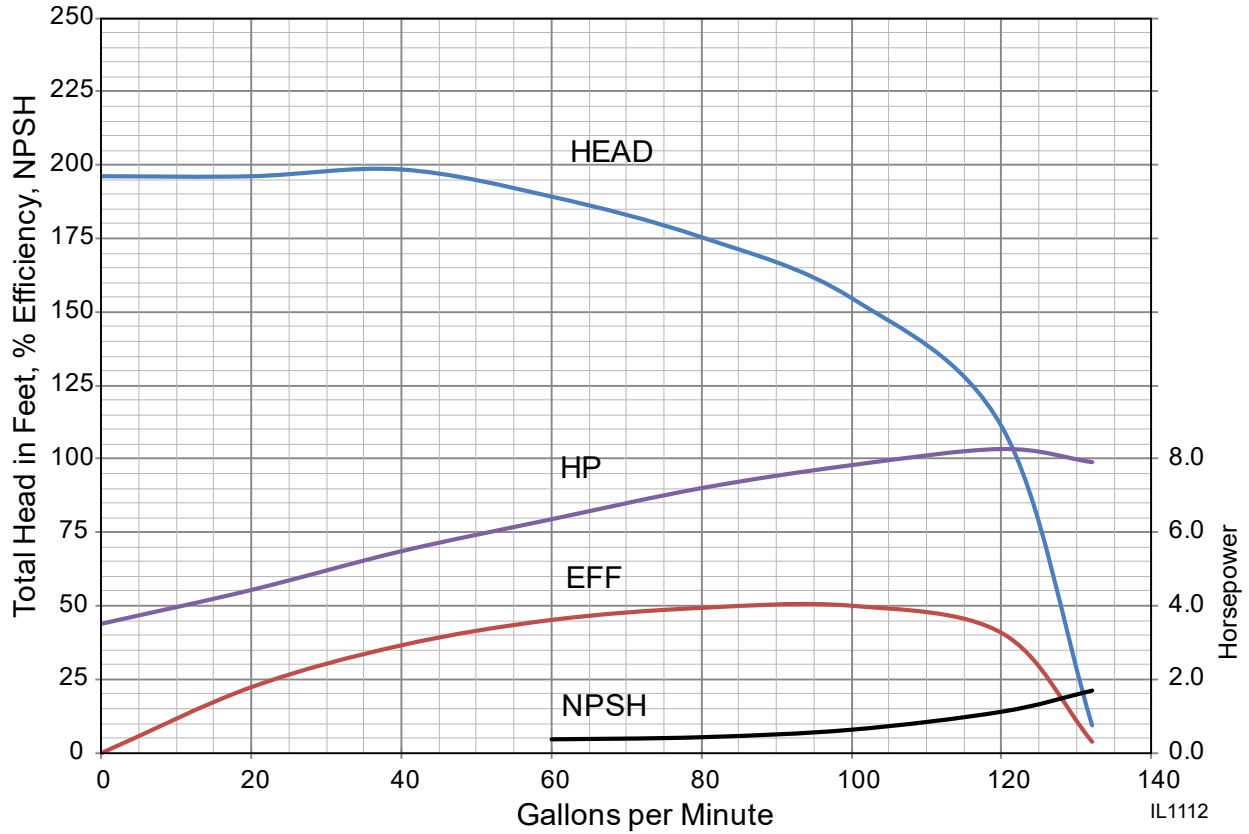

CJ103 CJ101 Dimensions

CJ103 SERIES

	HP	A	B	C	D	E	F	G	H	J	K	L
	1/3	4	4-5/8	3-11/16	5	9-1/2	2-1/8	8-1/4	8-1/8	13-1/4	3-7/8	-
	1/2	4	4-5/8	3-11/16	5	9-1/2	2-1/8	8-1/4	8-1/8	13-1/2	3-7/8	-
	3/4	4	4-5/8	3-11/16	5	9-1/2	2-1/8	8-1/4	8-1/8	14	3-7/8	-
	1	4	4-5/8	3-11/16	5	9-1/2	2-1/8	8-1/4	8-1/8	14-1/2	3-7/8	10-1/4
	1-1/2	4	4-5/8	3-11/16	5	9-1/2	2-1/8	8-1/4	8-1/8	15-1/8	3-7/8	10-1/4
1 Phase	3	4	4-5/8	3-11/16	5	9-1/2	2-1/8	8-1/4	8-1/8	15-5/8	3-7/8	10-1/4
3 Phase	2	4	4-5/8	3-11/16	5	9-1/2	2-1/8	8-1/4	8-1/8	15-5/8	3-7/8	-

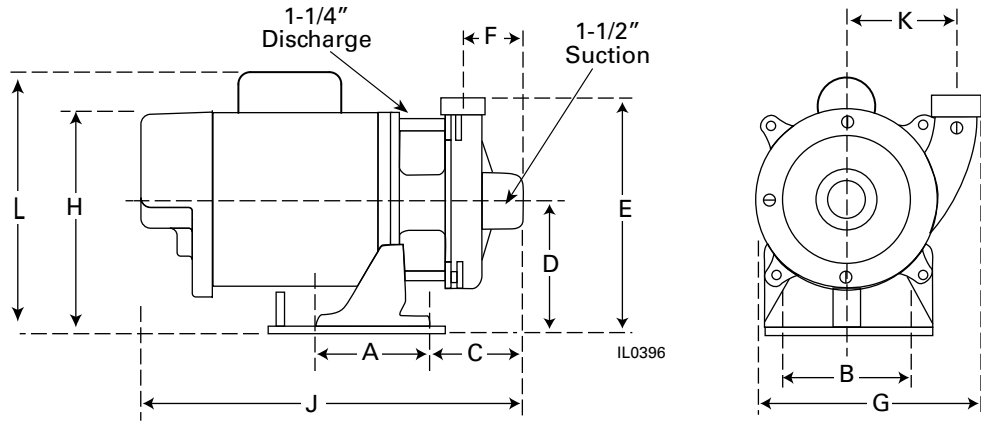

CJ101 SERIES

	HP	STAGE	A	B	C	D	E	F	G	H	J	L
	3/4	2	4	4-5/8	7-9/16	5-1/4	9-1/4	6-1/4	7	8-1/2	17-7/8	-
	1	2	4	4-5/8	7-9/16	5-1/4	9-1/4	6-1/4	7	8-1/2	18-3/8	-
	1-1/2	2	4	4-5/8	7-9/16	5-1/4	9-1/4	6-1/4	7	8-1/2	19	-
	2	2	4	4-5/8	7-9/16	5-1/4	9-1/4	6-1/4	7	8-1/2	19-1/2	-
	2	3	4	4-5/8	9-7/16	5-1/4	9-1/4	8-1/8	7	8-1/2	21-3/8	-
	3	3	4	4-5/8	9-7/16	5-1/4	9-1/4	8-1/8	7	8-1/2	21-3/8	10-5/8

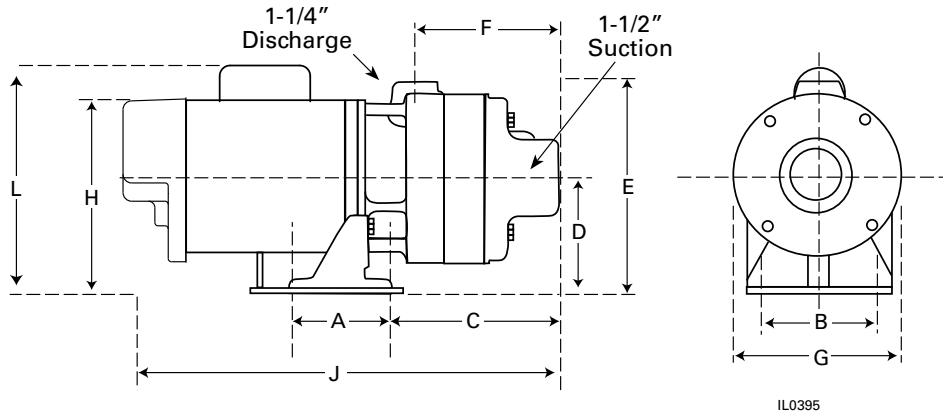

C22000 Dimensions



C22000												
HP	STAGE	PH	A	B	C	D	E	F	G	H	J	K
3	2	1	4-1/2	7-1/2	11-3/4	4-1/2	10-13/16	5-11/16	10-7/8	10-11/16	20-5/8	3-7/16
3	2	3	5	5-1/2	11-1/8	3-1/2	9-13/16	5-11/16	10-3/16	6-7/8	18-1/4	3-7/16
5	2	1	5-1/2	7-1/2	11-3/4	4-1/2	10-13/16	5-11/16	10-13/16	11-3/16	20-5/8	3-7/16
5	2	3	4-1/2	7-1/2	11-3/4	4-1/2	10-13/16	5-11/16	10-13/16	8-7/16	20-5/8	3-7/16
7-1/2	2	3	5-1/2	7-1/2	11-3/4	4-1/2	10-13/16	5-11/16	10-13/16	8-7/16	20-5/8	3-7/16

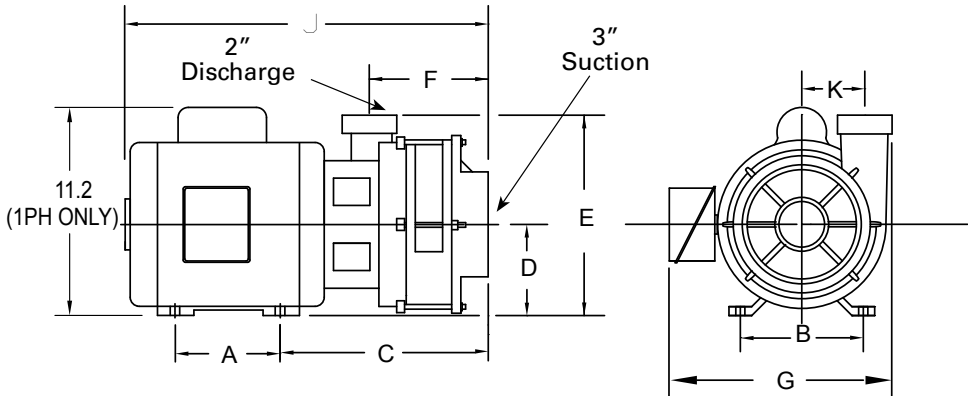

IL1106

SPJ 07-1 SELF-PRIMING PUMP SPJ07P1

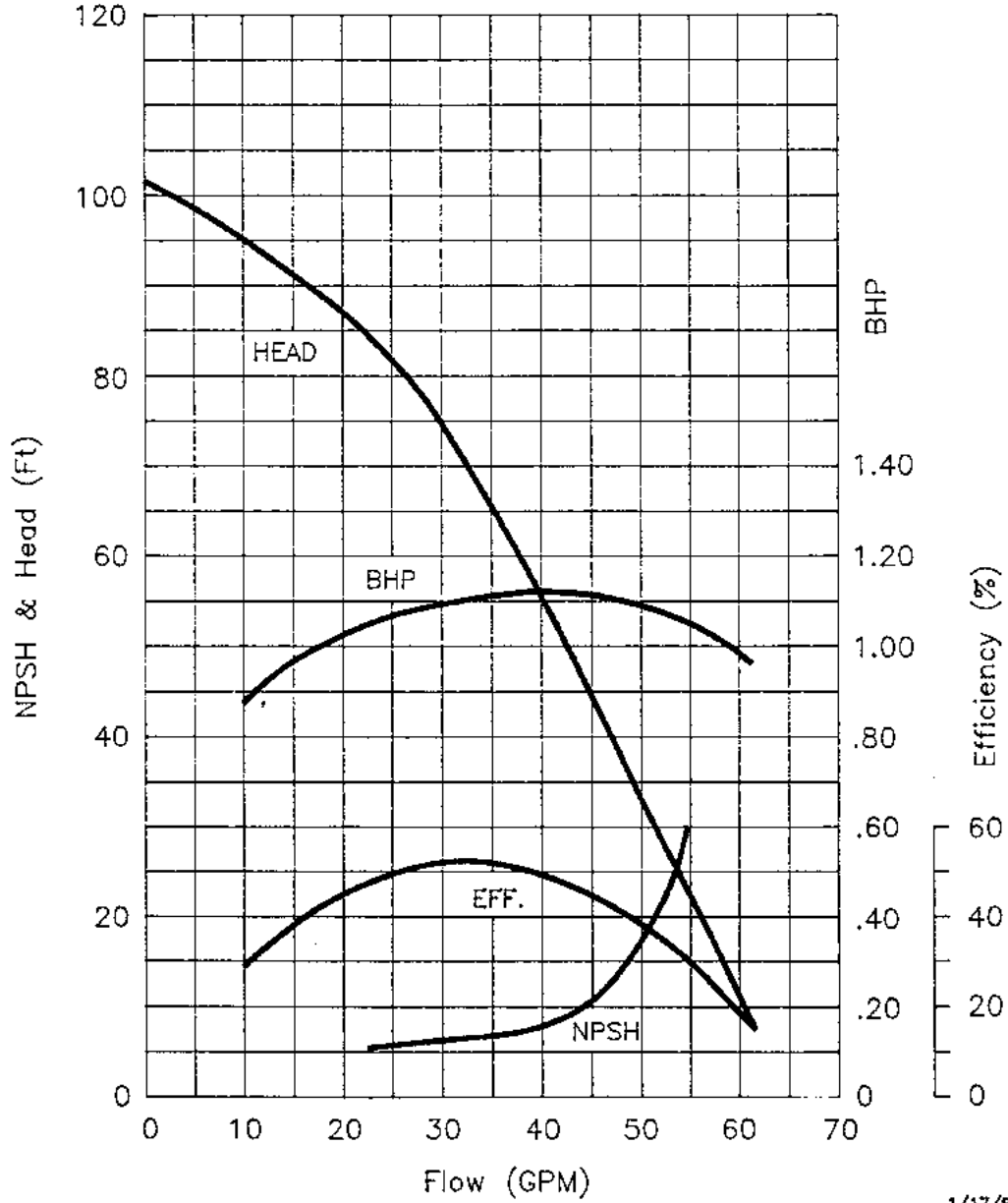

1/17/98
80

SPJ 10-1 SELF-PRIMING PUMP SPJ10P1

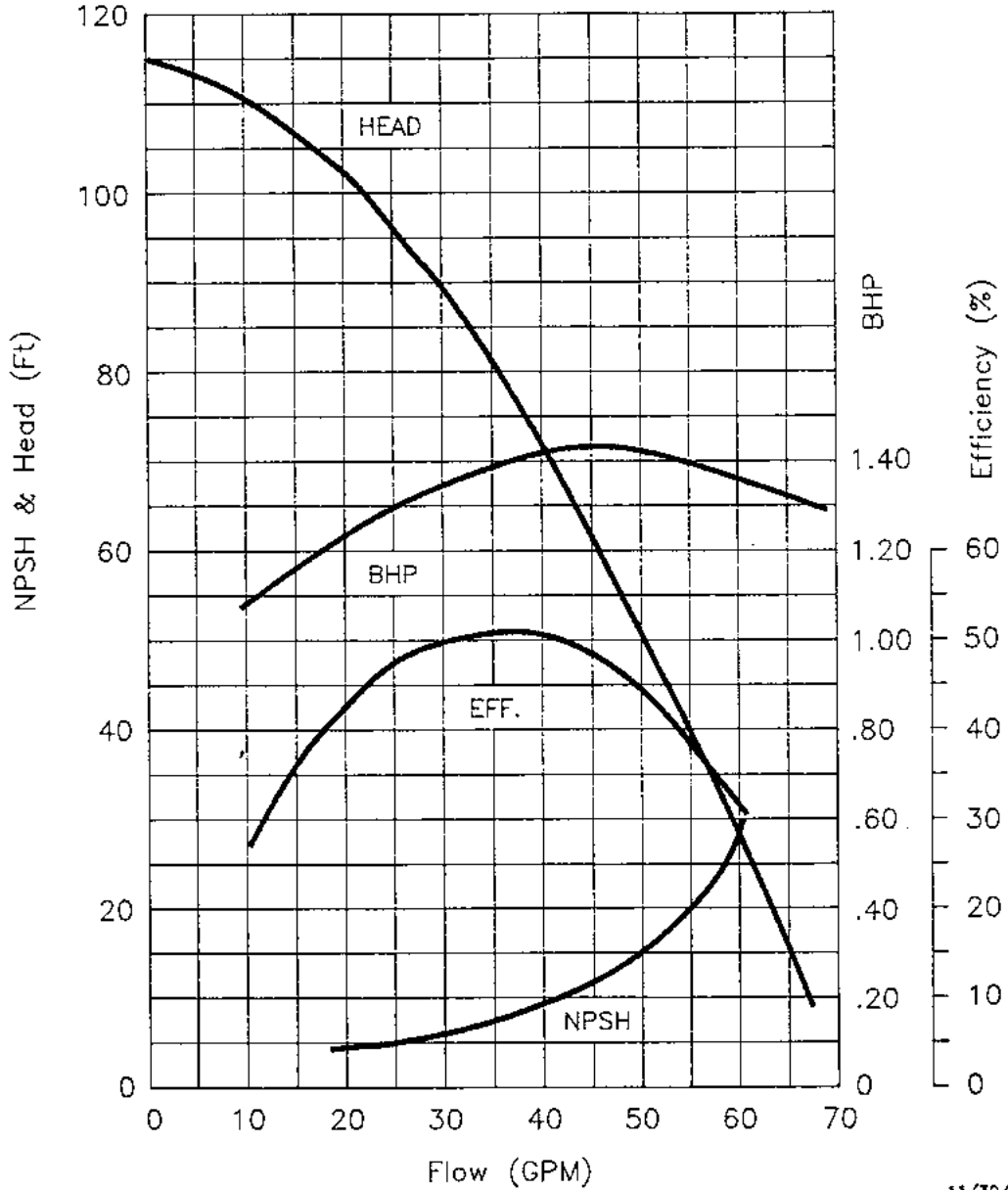

11/30/95
BD

SPJ 15-1 SELF-PRIMING PUMP SPJ15B1

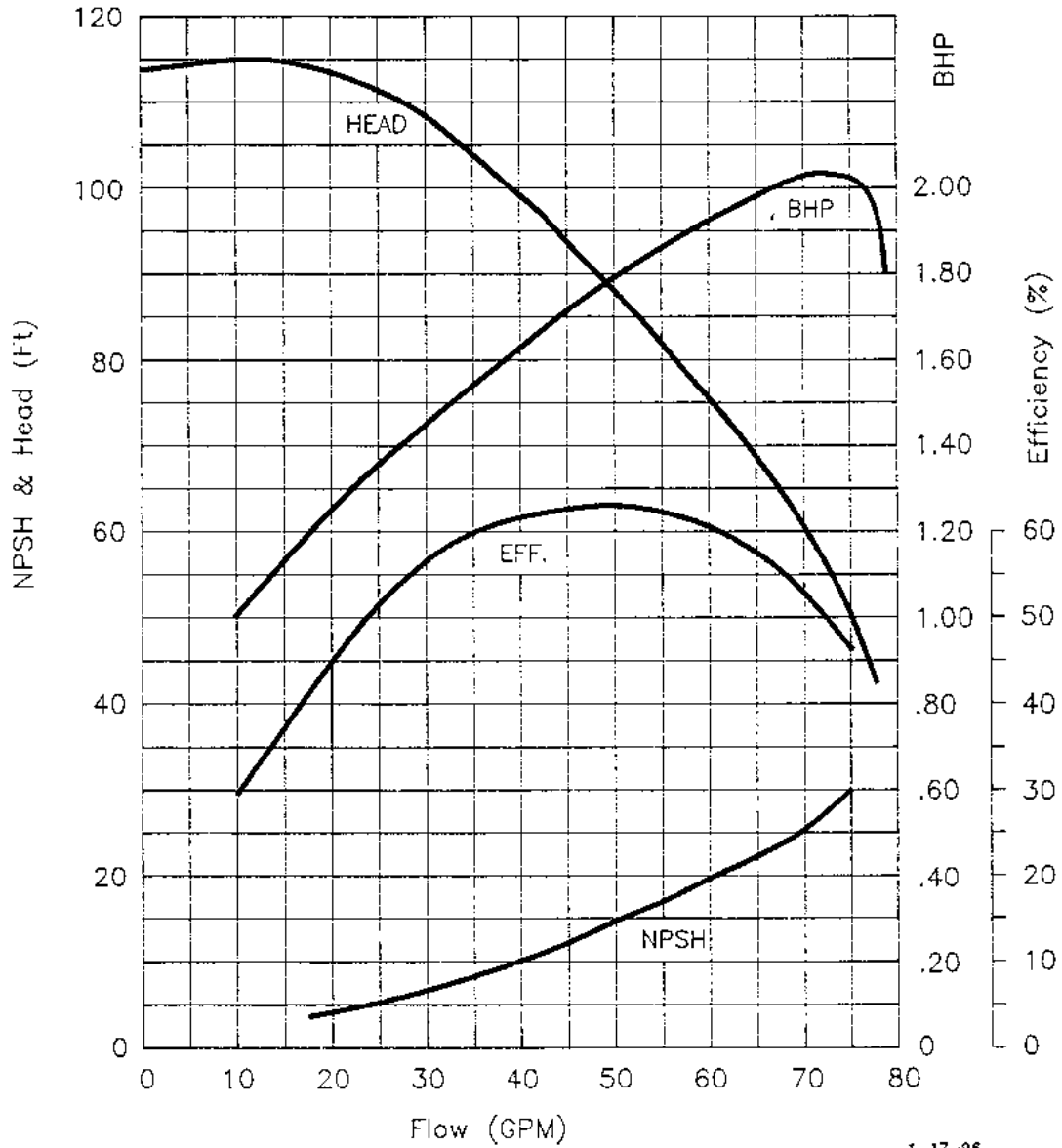

1-17-96
80

SPJ 20-1 SELF-PRIMING PUMP SPJ20B1

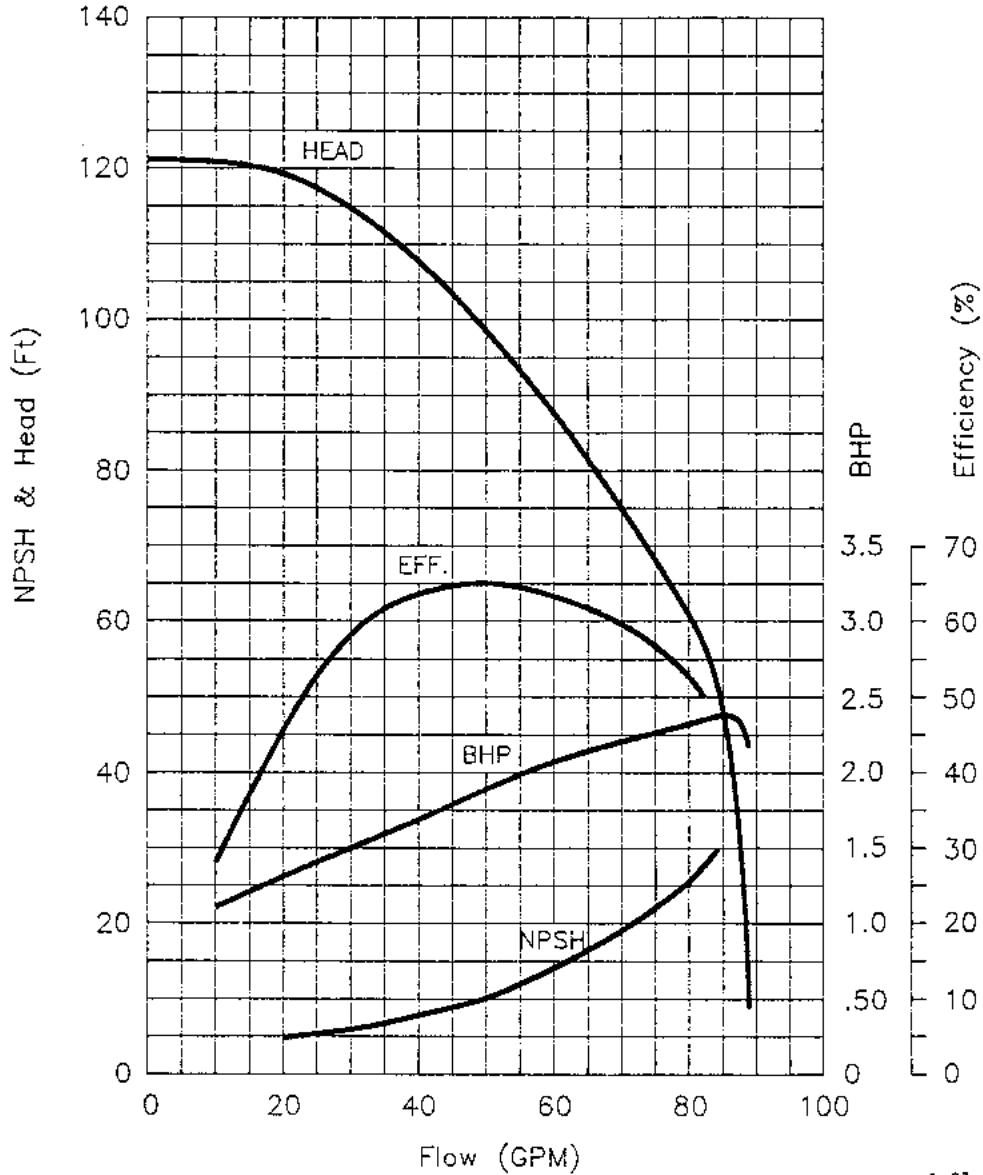

1-23-96
BO

SPJ 30-1 SELF-PRIMING PUMP SPJ30B1

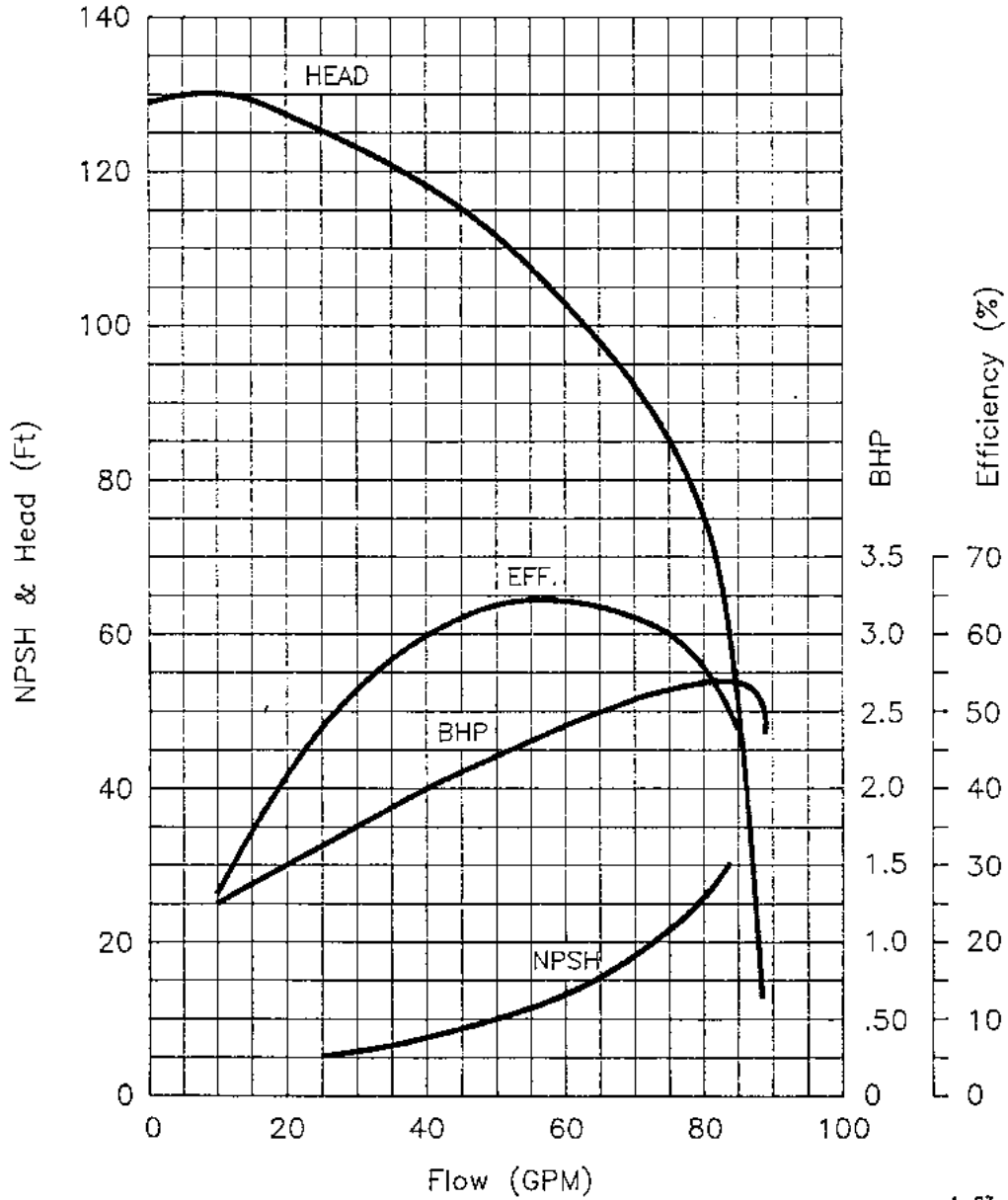

1-23-96
B0

Centrifugal Applications by Industry



Airports & Space Industries			
• Wash Down	• Cooling	• De-icing Airplanes and Equipment	• Circulator Pumps
Agriculture Industry			
• Insecticide- Grain Processing	• Beef & Hog Farms	• Commercial Farms	• Disinfecting
• Liquid Fertilizer	• Weed Killer	• Fish Farms	• Misting
• Brooder Houses- F&W Chicken Pump	• Irrigation	• De-watering	• Drip Systems
• High Pressure Cleaning Dairies			
Air Conditioning & Refrigeration Industry			
• Cooling Towers	• Brine Handling	• Circulating	• Mist Cooling
Boats - Barges Marine Industry			
• Solvents- Transfer & Circulating	• Radiator Cleaning (Repair shops/stations/garages)	• Pressure Testing	• Fire
• Anti-Freeze	• Transmission Fluid	• Bilge	
Automotive Industry			
• Fresh Water-Portable Water	• Sanitary Systems	• Car Wash	• Liquid Car Wax
• Wash Down-Marina	• Flushing		
Chemical Industry			
• Soaps	• Solvents	• Detergents	• Agriculture Chemicals
• Cleaners			
Heat Exchanger & Chillers			
• Radar, Sonar, TV & Radio	• Slicing & Sawing Blade Cooling	• Chiller- Brine Handling	• Automobile Welding
• Transmitter Cooling	• Hot Water, Hot Oil, Ethylene Glycol	• Laser Beam Cooler	• De-Icing
Concrete & Paving Industry			
• Additives (ad mixture) Metering	• Spray Pumps	• Booster	• Circulation
• Wash Down			
Construction			
• Heat Pump- Well Source	• Condensate Return	• City Main Pressure Testing	• Solar Heating
• De-watering			
Food Processing Industry			
• Seafood Processing	• Transferring & Circulating Cooking Oil	• Heat Transfer- Peanut Brittle	• Can & Bottle Warmers
• Meat Packing	• Boiler Feed for Sterilizers	• Breweries	• Creameries
• Bottling	• Circulating	• Bakeries	• Dairies
• Canneries	• Condensate return for Cooking Kettle Steam	• Can & Bottle Washers	

Foundries			
• Scrubbers	• Sprayers		
Laundry & Dry Cleaning Industry			
• Boiler Feed	• Transfer	• Washing Machines	• Coin-Op Laundries
• Condensate Return	• Filtration	• Water Reclamation	• Alteration Shop
Lumber Industries			
• Plywood Curing	• Wash Down	• De-barking	
Machine Tool Industry			
• EDM (Electrical Discharge Machines)	• Circulating Cutting & Cooling Oils	• Welding (Plasma Arc)	• Hydraulic Press Operation
• Electrolyte	• Filtering		
Manufacturing Plants - General			
• Sprinkler Systems	• Booster	• Condensation Return	• Testing Valves, Water Lines
• Air Conditioning	• Cooling Towers	• De-watering	• Quenching Oil
• Transfer			
Meat Packing Plants			
• Brine Injection- Pickling Hams	• Hide Removal	• Wash Down	• Circulation
• Booster Service			
Medical - Dental & Hospitals			
• Sterilizers for Instruments	• Boosters	• Dialysis Machines	• Circulators
• Electric Boilers			
Mining Industry			
• De-watering	• Dust Control		
Municipalities			
• Water Works	• Chlorine Injection	• De-icing Ponds	• Jockey Pumps
• Water Treatment	• Water Main Testing	• Ice Control	
Paper & Pulp Industry			
• Paper Mills	• Ink Pumps	• Coating	
Plastic & Rubber Industry			
• Heat Transfer in Molding	• Recapping Tires	• Boiler Feed	
Plating Industry			
• Photo Engraving	• Inks	• De-watering	
Printing Industry			
• Circulation	• Plate Making		
Recreation Industry			
• Water Falls	• Shooting Galleries	• Golf Courses	• Race Tracks
• Hydraulic Water Pumps for Animation	• Swimming Pools	• De-icing Marinas	• Weed Killers (lily pads)
• Balloon Making	• Ice Rinks	• Snow Machines	
Refineries			
• Loading/Unloading Product	• Process	• Canning Oil	• Cooling Heat Exchanger
• Transfer			
Sewage			
• Injection	• Wash Down	• Washing	
Textile Industry			
• Dyeing	• Washing		
Water & Wastewater Treatment			
• Scrubbers- Anti Pollution Equipment	• Brine Circulation	• Filtration	• Water Reclamation
• Froth Spray Pumps	• Water Softener Regeneration Plants	• Aspirators	

Commander® Pro Variable Frequency Drives



COMMANDER® PRO VARIABLE FREQUENCY DRIVES

FW1677
0920
Supersedes
1219

DESIGNED FOR THE PROFESSIONAL PUMP INSTALLER

- Easy to read diagnostic display
- Increases flow as demand increases
- Available with pressure switch or pressure transducer
- Adjustable constant pressure
- Automatic pump and motor protection
- Superior cooling and dust protection
- Meets Part 15 Class A FCC electronic interference standards
- Programming lockout for secure operation
- Tamper proof cover
- Automatic fan designed to maximize cooling
- NEMA 3R for indoor/outdoor use



VS and TVS Series
Variable Frequency Drives and Systems



FCC Part 15 Class A

Commander® Pro Variable Frequency Drives

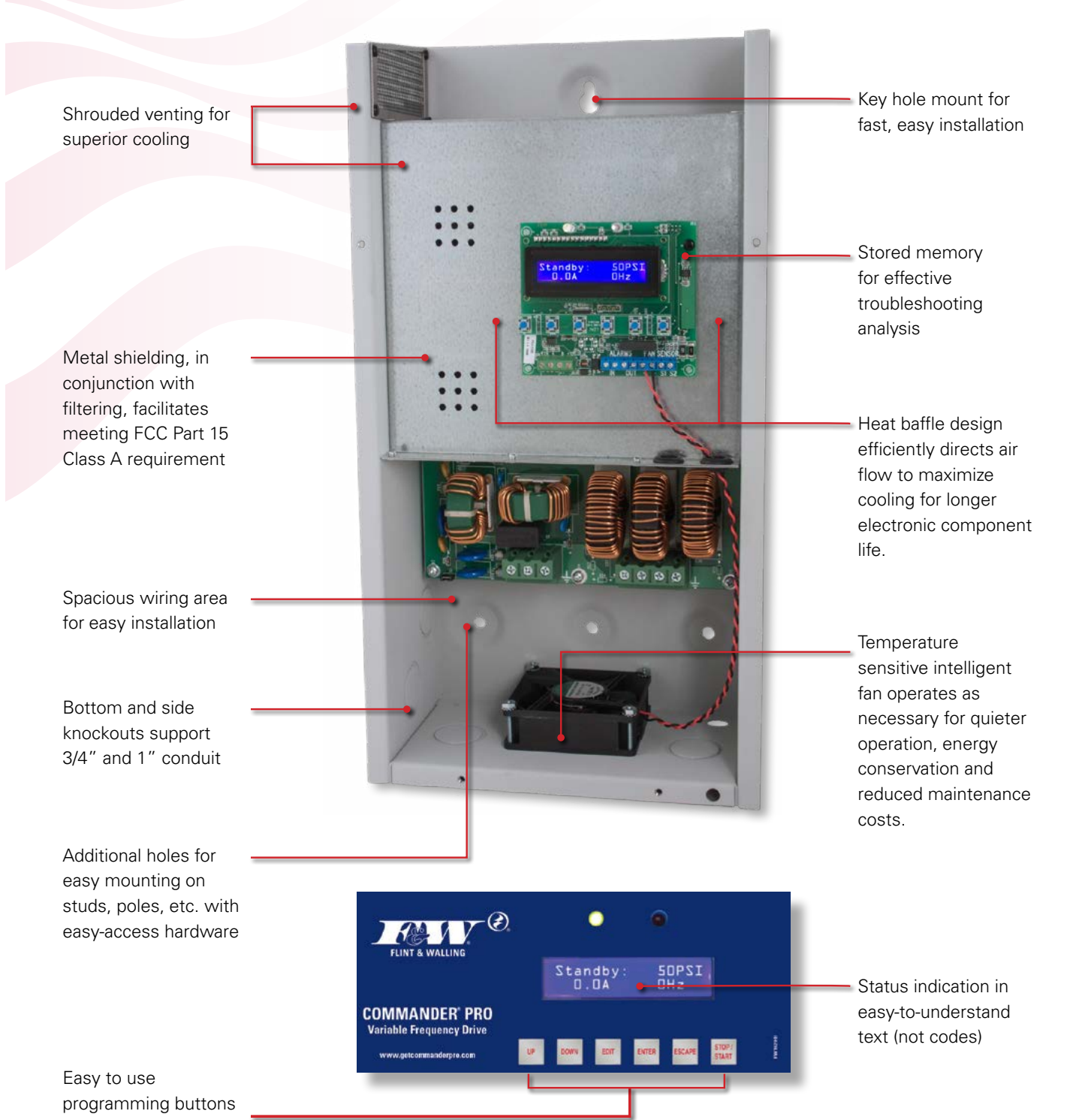

Shrouded venting for superior cooling

Key hole mount for fast, easy installation

Metal shielding, in conjunction with filtering, facilitates meeting FCC Part 15 Class A requirement

Stored memory for effective troubleshooting analysis

Heat baffle design efficiently directs air flow to maximize cooling for longer electronic component life.

Spacious wiring area for easy installation

Temperature sensitive intelligent fan operates as necessary for quieter operation, energy conservation and reduced maintenance costs.

Bottom and side knockouts support 3/4" and 1" conduit

Additional holes for easy mounting on studs, poles, etc. with easy-access hardware

Status indication in easy-to-understand text (not codes)

Easy to use programming buttons



Commander® Pro Variable Frequency Drives



1.5, 2, 3 and 5 HP Constant Pressure Systems for Home, Irrigation & Deep Well Applications

The Commander Pro VS and TVS series of pre-packaged constant pressure water systems are designed specifically for demanding applications. These models are engineered to provide a constant pressure water supply from as deep as 950' or at flows from 2 to 325 GPM.

These systems feature Flint & Walling 4" submersible pump end, pressure transducer or pressure switch, single phase input and NEMA 3R enclosures

Applications include:

Residential Water Systems

- City-like water pressure
- Smaller tank saves space

Geothermal Systems

- No need for large buried tanks
- Eliminates pressure cycling

Lawn Irrigation Systems

- Even distribution of water in zones
- Eliminates need for separate system

Water Treatment Systems

- More efficient back flushing
- No need for multiple pumps

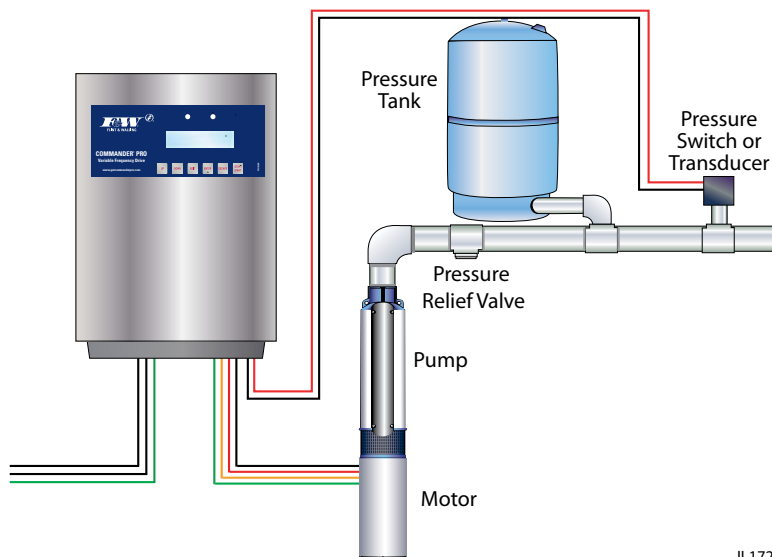

IL1721

Wire Sizing

The maximum allowable wire lengths for connection of controller to the main circuit box are given in the following table.

Maximum Wire Lengths Connecting the Controller to The Main Circuit Box (Based On 3% Voltage Drop At 230V)										
Motor HP	Copper Wire Size (AWG)	14	12	10	8	6	4	3	2	Circuit Breaker
1.5/2	Max. Length. (Ft.)		85*	140*	220	345	550	680	895	20 Amp
3				115*	180	285	455	560	740	25 Amp
5					115	185	290	360	470	40 AMP

* Wire with 90°C Insulation only

GENERAL SPECIFICATIONS

Commander Pro Series	Commander Pro 15 Series	Commander Pro 20 Series	Commander Pro 30 Series	Commander Pro 50 Series - VFD Only
Model Number	TVS15	TVS20	TVS30	TVS50
Horsepower	Up to 1.5 HP Three Phase	Up to 2 HP Three Phase	Up to 3 HP Three Phase	Up to 5 HP Three Phase
Input Voltage	200 – 250 V Single Phase			
Input Frequency	60/50 Hz			
Input Amps (RMS)	11 Amps	19 Amps	23 Amps	35 Amps
Input Power (Idle)	35 Watts	65 Watts	65 Watts	70 Watts
Output Phase	3-wire Single Phase: 1/2 HP – 2 HP			
	Up to 1.5 HP Three Phase	Up to 2 HP Three Phase	Up to 3 HP Three Phase	Up to 5 HP Three Phase
Output Frequency	Variable (30 – 80 Hz) Three Phase, (30 - 60 Hz) 3 Wire Single Phase			
Pressure	25 – 80 PSI (preset to 50 PSI) all units			
Ambient Temp. Range	-20° C (-4° F) to 50° C (122° F)			

City-like water pressure for rural water systems in one complete package

Systems include:



Commander Pro Variable Frequency Drive with advanced electronics. NEMA 3R enclosure.



Factory specified pump end for optimal performance and efficiency.



Proven water-lubricated motor. Performance matched for long life. Specified to avoid overload.

Pressure switch¹



¹024545 - Pressure switch kit w/lead
¹023049 - Pressure switch only

Pressure transducer²

or



²024586 - Pressure transducer kit (0-100PSI), factory installed
²024577 - Pressure transducer only (0 - 100 PSI)
²024587 - Pressure transducer kit (0-300 PSI)
²024585 - Pressure transducer only (0-300 PSI)

Commander® Pro Variable Frequency Drives



Commander® PR015

DIMENSIONS

Model	Disch.	Pump Dia.*	Pump Length	Motor Dia.	Motor Length	Total Length
VS1507LT TVS1507LT	1-1/4"	3.88"	19.4"	3.75"	11.8"	31.2"
VS1510LT TVS1510LT	1-1/4"	3.88"	18.9"	3.75"	11.8"	30.7"
VS1519LT TVS1519LT	1-1/4"	3.88"	17.0"	3.75"	11.8"	28.8"
VS1527LT TVS1527LT	1-1/4"	3.88"	15.3"	3.75"	11.8"	27.1"

* Including Cable Guard

For models with pressure transducer, add a "T" prefix to the model, i.e. TVS1507LT.

NEMA 3R.

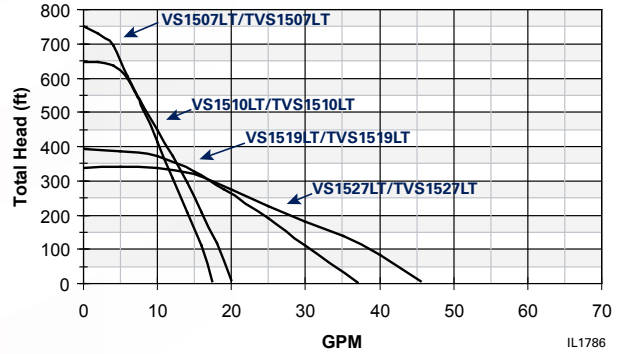

Pumping Depth in Feet	GPM @ Pressure Sensor Setting					Max. Shut-Off (PSI)
	30	40	50*	60	70	
						324
20	16.3	16.0	15.6	15.1	14.6	
40	16.1	15.6	15.1	14.6	14.1	
60	15.7	15.2	14.7	14.2	13.7	
80	15.3	14.8	14.2	13.8	13.3	
100	14.8	14.3	13.8	13.3	12.9	
120	14.4	13.9	13.4	12.9	12.5	
140	14.0	13.5	13.0	12.5	12.1	
160	13.5	13.1	12.6	12.1	11.7	
180	13.1	12.7	12.2	11.8	11.3	
200	12.7	12.3	11.8	11.4	10.9	
220	12.3	11.9	11.5	11.0	10.6	
240	12.0	11.5	11.1	10.6	10.2	
260	11.6	11.1	10.7	10.3	9.8	
280	11.2	10.8	10.3	9.9	9.4	
300	10.8	10.4	9.9	9.5	9.0	
350	9.9	9.4	8.9	8.4	7.9	
400	8.9	8.3	7.9	7.4	6.9	
450	7.8	7.3	6.8	6.4	5.9	
500	6.7	6.3	5.8	5.4	5.0	
550	5.8	5.3	4.9	4.4	3.7	
600	4.8	4.3	3.5	1.5	-	
650	3.3	.8	-	-	-	

* Factory preset 50 PSI

Model VS1507LT, TVS1507LT

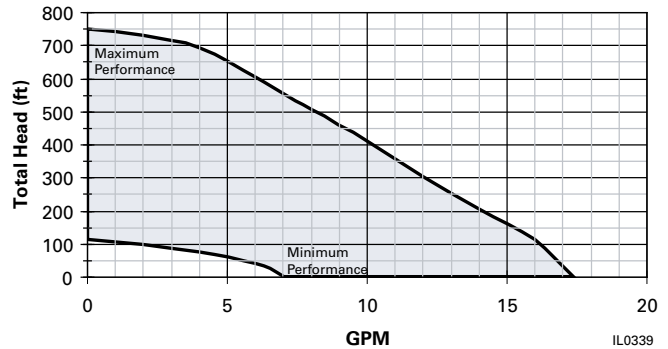

Pumping Depth in Feet	GPM @ Pressure Sensor Setting					Max. Shut-Off (PSI)
	30	40	50*	60	70	
						280
20	18.6	18.1	17.8	17.2	16.8	
40	18.2	17.7	17.2	16.7	16.2	
60	17.8	17.2	16.8	16.2	15.8	
80	17.3	16.8	16.3	15.8	15.3	
100	16.9	16.4	15.8	15.3	14.8	
120	16.4	15.9	15.4	14.9	14.4	
140	16.0	15.5	14.9	14.4	13.8	
160	15.6	15.0	14.4	13.9	13.4	
180	15.1	14.6	14.0	13.4	12.8	
200	14.8	14.1	13.5	12.9	12.2	
220	14.1	13.8	12.9	12.3	11.8	
240	13.6	13.0	12.4	11.8	11.2	
260	13.1	12.5	11.9	11.3	10.7	
280	12.6	12.0	11.4	10.8	10.2	
300	12.0	11.4	10.8	10.3	9.6	
350	10.8	10.1	9.5	8.8	8.2	
400	9.4	8.8	8.1	7.5	7.0	
450	8.2	7.4	6.3	6.3	5.5	
500	6.8	6.2	4.0	3.9		
550	5.1	3.8				

* Factory preset 50 PSI

Model VS1510LT, TVS1510LT

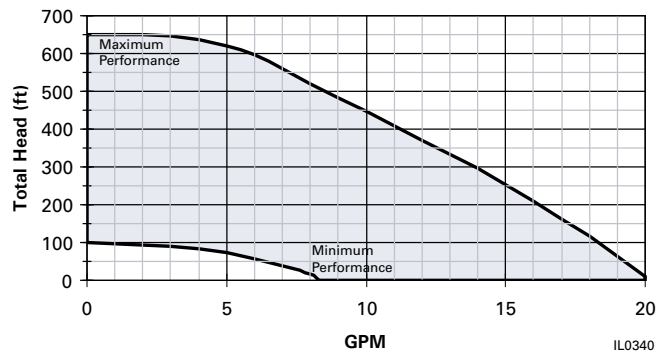

Commander® PR015

Pumping Depth in Feet	GPM @ Pressure Sensor Setting					Max. Shut-Off (PSI)
	30	40	50*	60	70	
						169
20	31.8	30.0	28.5	27.2	26.3	
40	30.2	28.7	27.4	26.0	24.2	
60	29.0	27.5	26.0	24.5	22.7	
80	27.7	26.3	24.6	23.0	21.2	
100	26.5	25.0	23.1	21.5	19.5	
120	25.2	23.0	21.6	20.0	18.0	
140	23.7	22.0	20.0	18.5	16.8	
160	22.1	20.2	18.5	17.0	15.2	
180	20.6	18.7	17.2	15.2	13.5	
200	19.0	17.5	15.7	13.9	11.4	
220	17.7	16.0	14.0	11.9	7.0	
240	16.3	14.4	12.0	9.9		
260	14.6	12.5	9.0			
280	12.7	9.9				
300	10.3					

* Factory preset 50 PSI

Model VS1519LT, TVS1519LT

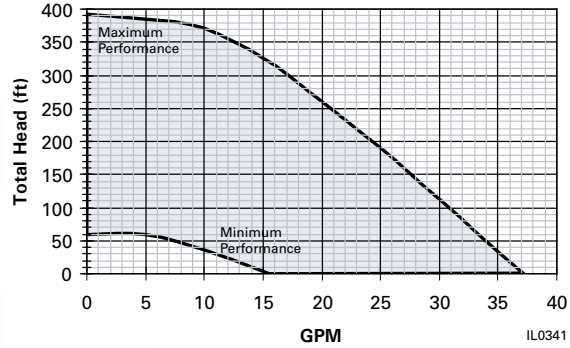

Pumping Depth in Feet	GPM @ Pressure Sensor Setting					Max. Shut-Off (PSI)
	30	40	50*	60	70	
						146
20	39.5	37.5	35.4	33.0	30.0	
40	37.9	35.6	33.2	30.5	27.4	
60	36.0	33.5	30.9	28.0	25.0	
80	34.0	31.2	28.2	25.3	22.8	
100	31.5	28.6	25.6	23.1	20.6	
120	29.1	25.6	23.5	21.2	18.9	
140	26.4	23.8	21.4	19.2	16.9	
160	24.2	21.8	19.5	17.2	14.4	
180	22.1	19.8	17.5	15.1		
200	20.0	17.9	15.3	14.5		
220	18.2	15.9	10.3			
240	16.2	11.8				
260	13.0					

* Factory preset 50 PSI

Model VS1527LT, TVS1527LT

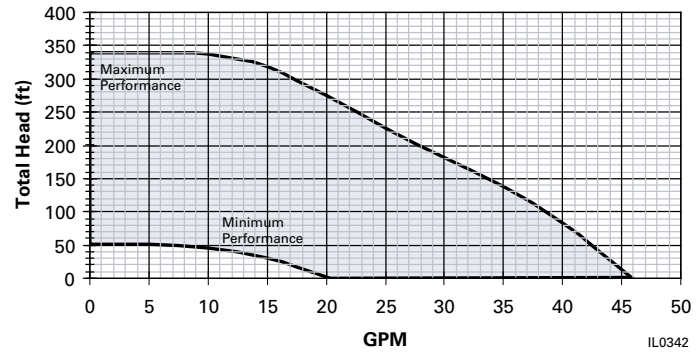

Commander® Pro Variable Frequency Drives



Commander® PRO20

DIMENSIONS

Model	Disch.	Pump Dia.*	Pump Length	Motor Dia.	Motor Length	Total Length
VS2007LT TVS2007LT	1-1/4"	3.88"	22.60"	3.75"	13.62"	36.22"
VS2010LT TVS2010LT	1-1/4"	3.88"	20.25"	3.75"	13.62"	33.87"
VS2019LT TVS2019LT	1-1/4"	3.88"	18.25"	3.75"	13.62"	31.87"
VS2027LT TVS2027LT	1-1/4"	3.88"	16.85"	3.75"	13.62"	30.47"
VS2035LT** TVS2035LT**	2"	3.88"	12.56"	3.75"	13.62"	26.18"

* Including cable guard

** VS2035LT/TVS2035LT does not include an internal check valve

For models with pressure transducer, add a "T" prefix to the model, i.e.

TVS2007LT

NEMA 3R.

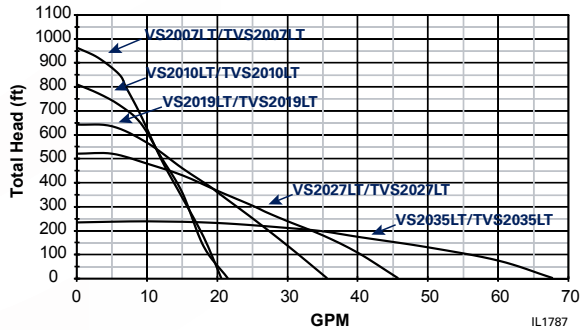

Pumping Depth in Feet	Maximum GPM @ Pressure Sensor Setting				Max. Shut-Off (PSI)
	40	50*	60	70	
					417
50	18.5	18.2	17.8	17.4	
100	17.7	17.3	16.9	16.4	
150	16.8	16.4	15.9	15.5	
200	15.9	15.4	15.0	14.5	
250	14.9	14.5	14.0	13.6	
300	13.93	13.5	13.0	12.6	
350	12.95	12.6	12.1	11.7	
400	12.05	11.7	11.3	11.0	
450	11.24	10.9	10.5	10.2	
500	10.46	10.1	9.7	9.4	
550	9.65	9.3	9.0	8.6	
600	8.87	8.5	8.1	7.7	
650	7.99	7.6	7.1	6.8	
700	7.05	6.7	6.4	5.7	
750	6.31	5.6	4.6	3.5	
800	4.44	3.3	1.9		
850	1.74				

*Factory preset to 50 PSI

Model VS2007LT, TVS2007LT

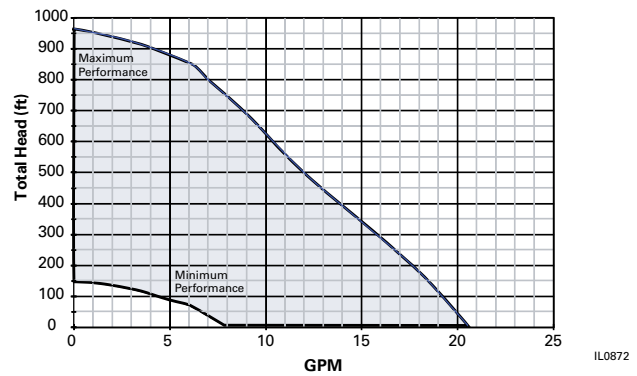

Pumping Depth in Feet	Maximum GPM @ Pressure Sensor Setting				Max. Shut-Off (PSI)
	40	50*	60	70	
					351
50	17.9	17.5	17.2	16.9	
100	17.1	16.9	16.6	16.3	
150	16.5	16.3	15.9	15.7	
200	15.9	15.6	15.3	14.9	
250	15.3	14.9	14.5	14.0	
300	14.37	13.9	13.4	13.0	
350	13.43	12.9	12.4	11.9	
400	12.25	11.8	11.4	10.9	
450	11.31	10.8	10.4	9.9	
500	10.33	9.8	9.3	8.7	
550	9.17	8.6	7.7	6.7	
600	7.56	6.5	5.4		
650	5.01				

*Factory preset to 50 PSI

Model VS2010LT, TVS2010LT

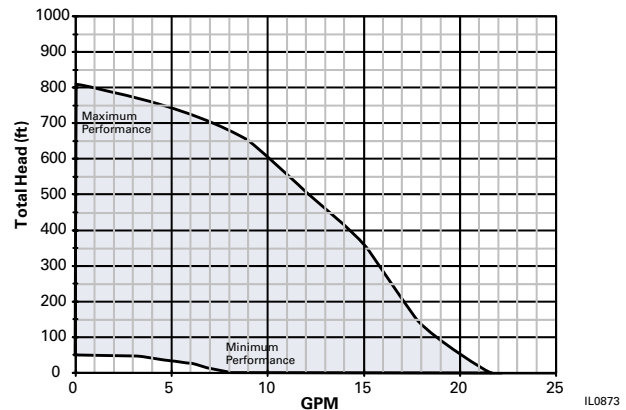

Commander® PR020

Pumping Depth in Feet	Maximum GPM @ Pressure Sensor Setting				Max. Shut-Off (PSI)
	40	50*	60	70	
					278
50	29.8	28.8	27.8	26.8	
100	27.6	26.5	25.6	24.5	
150	25.4	24.4	23.4	22.3	
200	23.2	22.1	21.0	19.9	
250	20.9	19.7	18.7	17.5	
300	18.5	17.3	16.1	15.0	
350	15.9	14.8	13.7	12.7	
400	13.6	12.5	11.5	10.3	
450	11.2	10.0	8.8	7.3	
500	8.5	7.0			

*Factory preset to 50 PSI

Model VS2019LT, TVS2019LT

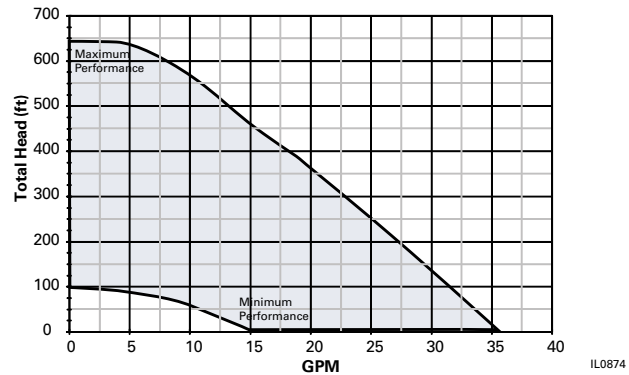

Pumping Depth in Feet	Maximum GPM @ Pressure Sensor Setting				Max. Shut-Off (PSI)
	40	50*	60	70	
					226
50	37.9	36.3	34.6	32.4	
100	34.1	32.1	30.1	28.2	
150	29.8	28.0	26.1	24.6	
200	26.0	24.1	22.2	20.4	
250	21.9	20.0	18.5	16.7	
300	18.18	16.4	14.5	12.1	
350	14.15	11.8	9.2	6.7	
400	8.75	6.2			

*Factory preset to 50 PSI

Models VS2027LT, TVS2027LT

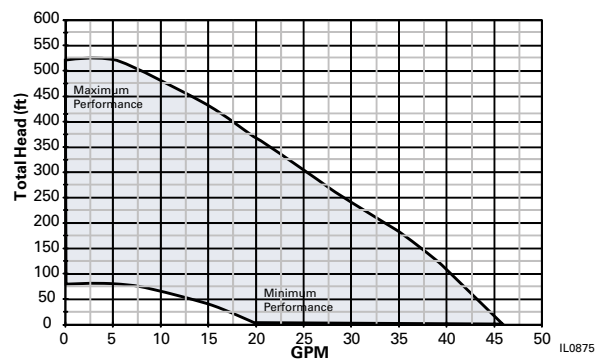

Pumping Depth in Feet	Maximum GPM @ Pressure Sensor Setting				Max. Shut-Off (PSI)
	40	50*	60	70	
					102
25	52.9	48.0	42.8	37.5	
50	47.8	42.2	37.1	30.2	
75	41.8	36.9	29.4	16.6	
100	36.4	28.6	14.3		
125	28.5	9.8			

*Factory preset to 50 PSI

**VS2035LT does not include an internal check valve

Models VS2035LT, TVS2035LT

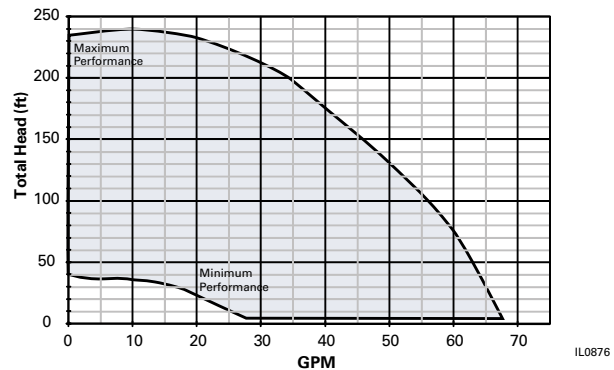

Commander® Pro Variable Frequency Drives



Commander® PRO30

DIMENSIONS

Model	Disch.	Pump Dia.*	Pump Length	Motor Dia.	Motor Length	Total Length
VS3007LT TVS3007LT	1-1/4"	3.88"	26.00"	3.75"	16.06"	42.1"
VS3010LT TVS3010LT	1-1/4"	3.88"	24.25"	3.75"	16.06"	40.3"
VS3019LT TVS3019LT	1-1/4"	3.88"	18.25"	3.75"	16.06"	34.3"
VS3027LT TVS3027LT	1-1/4"	3.88"	18.90"	3.75"	16.06"	35.0"
VS3035LT** TVS3035LT**	2"	3.88"	14.25"	3.75"	16.06"	30.3"
VS3055LT** TVS3055LT**	2"	3.88"	14.50"	3.75"	16.06"	30.6"
VS3085LT** TVS3085LT**	2"	3.88"	14.50"	3.75"	16.06"	30.6"

* Including Cable Guard

**VS3035LT, VS3055LT & VS3085LT do not include an internal check valve.

For models with pressure transducer, add a "T" prefix to the model, i.e. TVS3007LT NEMA 3R.

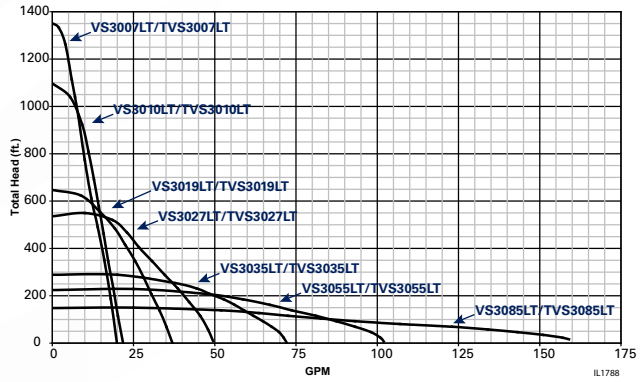

Pumping Depth in Feet	Maximum GPM @ Pressure Sensor Setting				Maximum Shut Off (PSI)
	40	50*	60	70	
100	18.0	17.7	17.4	17.2	585
150	17.4	17.1	16.8	16.5	
200	16.8	16.5	16.2	15.8	
250	16.1	15.8	15.5	15.1	
300	15.4	15.1	14.7	14.4	
350	14.7	14.3	13.9	13.6	
400	13.9	13.5	13.2	12.8	
450	13.1	12.8	12.4	12.1	
500	12.4	12.1	11.7	11.4	
550	11.7	11.4	11.1	10.8	
600	11.0	10.7	10.4	10.2	
650	10.4	10.1	9.8	9.6	
700	9.8	9.5	9.2	9.0	
750	9.2	8.9	8.7	8.4	
800	8.6	8.4	8.1	7.9	
850	8.1	7.8	7.6	7.3	
900	7.5	7.3	7.0	6.7	
950	7.0	6.7	6.4	6.1	
1000	6.4	6.1	5.8	5.5	
1050	5.8	5.5	5.1	4.8	
1100	5.1	4.7	4.4	4.0	
1150	4.3	3.9	3.4	2.8	
1200	3.3	2.7	1.7		
1250	1.4				

*Factory preset to 50 PSI

Model VS3007LT, TVS3007LT

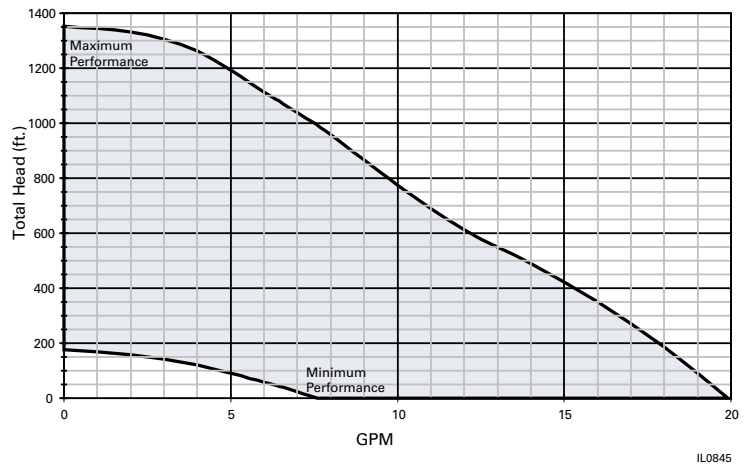

Commander® PR030

Pumping Depth in Feet	Maximum GPM @ Pressure Sensor Setting				Maximum Shut Off (PSI)
	40	50*	60	70	
					473
100	19.2	18.8	18.6	18.4	
150	18.4	18.2	17.8	17.7	
200	17.8	17.7	17.3	17.1	
250	17.3	16.9	17.2	16.3	
300	16.7	16.2	16.0	15.8	
350	16.1	15.8	15.3	15.2	
400	15.3	15.1	14.9	14.5	
450	14.8	14.4	14.1	13.9	
500	14.1	13.8	13.6	13.1	
550	13.5	13.1	12.8	12.6	
600	12.8	12.5	12.3	11.9	
650	12.2	11.8	11.5	11.2	
700	11.3	11.1	10.7	10.3	
750	10.6	10.2	10.0	9.5	
800	9.9	9.4	8.9	8.1	
850	8.7	8.1	7.5	6.5	
900	7.2	6.5	5.3		
950	5.3	4.5			

*Factory preset to 50 PSI

Model VS3010LT, TVS3010LT

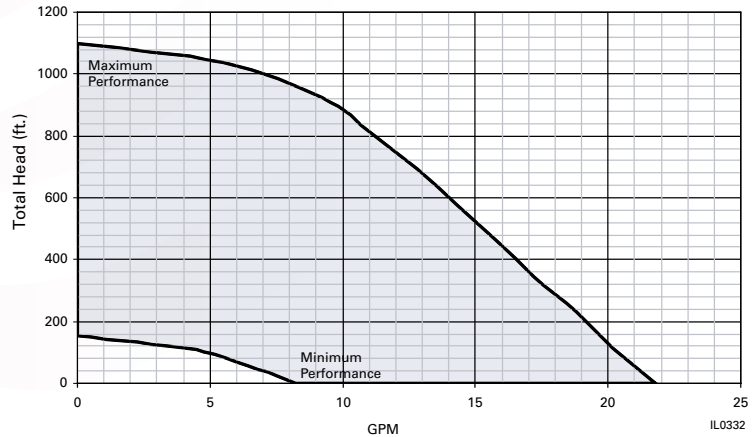

Pumping Depth in Feet	Maximum GPM @ Pressure Sensor Setting				Maximum Shut Off (PSI)
	40	50*	60	70	
					280
25	33.8	32.7	32.2	31.3	
50	32.7	32.0	31.2	30.3	
75	32.3	31.2	30.5	29.1	
100	30.9	30.3	29.3	28.6	
150	29.2	28.4	27.7	26.8	
200	27.4	26.6	25.8	24.8	
250	25.7	24.6	23.8	22.5	
300	23.5	22.4	21.5	20.5	
350	21.3	20.2	19.2	17.6	
400	18.9	17.3	15.6	13.9	
450	15.6	13.8	12.4	10.0	
500	12.0	9.9			

*Factory preset to 50 PSI

Model VS3019LT, TVS3019LT

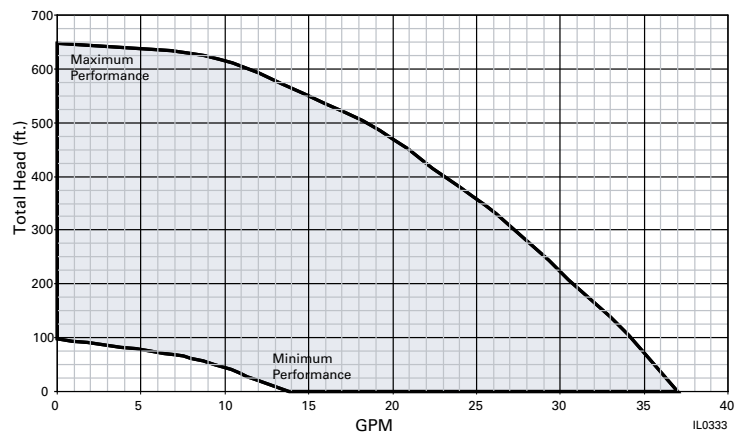

Pumping Depth in Feet	Maximum GPM @ Pressure Sensor Setting				Maximum Shut Off (PSI)
	40	50*	60	70	
					233
25	45.3	43.9	42.6	41.3	
50	43.8	42.5	41.2	39.9	
75	42.4	41.1	39.8	37.3	
100	41.0	39.7	38.2	36.5	
150	37.9	36.1	34.6	33.0	
200	34.4	32.6	31.2	29.7	
250	31.0	29.5	27.7	26.2	
300	27.4	25.8	24.7	23.5	
350	24.4	23.2	21.5	19.7	
400	21.3	19.0			

*Factory preset to 50 PSI

Model VS3027LT, TVS3027LT

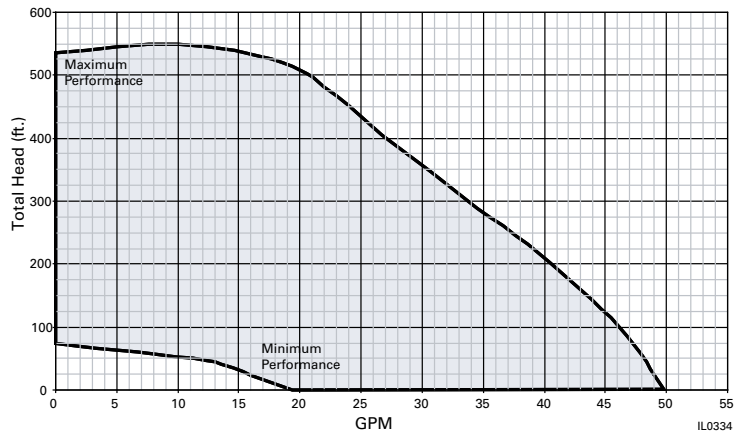

Commander® Pro Variable Frequency Drives



Commander® PRO30

Pumping Depth in Feet	Maximum GPM @ Pressure Sensor Setting				Maximum Shut Off (PSI)
	40	50*	60	70	
					122
25	62.0	58.0	56.0	52.0	
50	58.0	56.0	52.0	47.0	
75	56.0	52.0	47.0	42.0	
100	52.0	47.0	42.0	33.0	
125	47.0	42.0	33.0	21.0	
150	42.0	32.0	19.0		
175	32.0	15.0			

*Factory preset to 50 PSI

**Does not include an internal check valve

Model VS3035LT, TVS3035LT

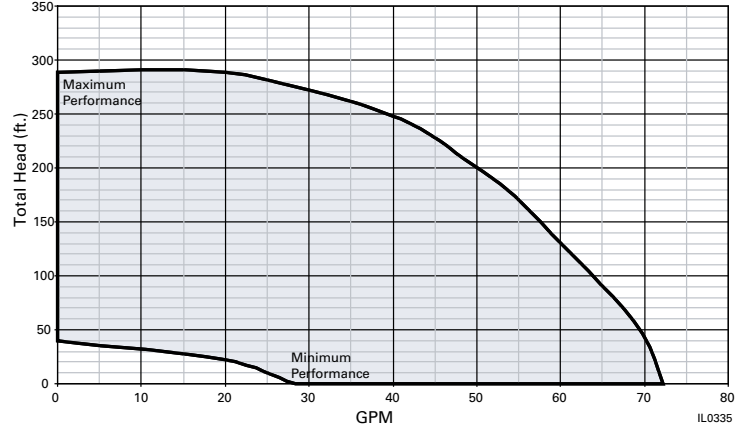

Pumping Depth in Feet	Maximum GPM @ Pressure Sensor Setting				Maximum Shut Off (PSI)
	40	50*	60	70	
					98
25	81.0	73.0	66.0	57.7	
50	72.0	65.0	56.7	44.1	
75	64.3	56.0	43.0		
100	55.4	42.0			
125	40.9				

*Factory preset to 50 PSI

**Does not include an internal check valve

Model VS3055LT, TVS3055LT

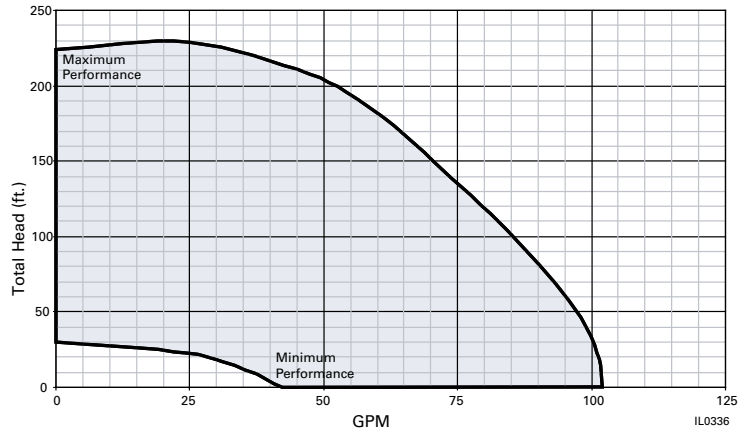

Pumping Depth in Feet	Maximum GPM @ Pressure Sensor Setting			Maximum Shut Off (PSI)
	30	40	50*	
				64
0	122.0	95.0	73.0	
5	117.0	87.0	69.0	
10	108.0	83.0	64.0	
15	103.0	78.0	60.0	
20	97.0	75.0	54.0	
25	92.0	72.0	46.0	
30	86.0	68.0	38.0	
35	82.0	63.0		
40	78.0	55.0		
50	68.0	45.0		

*Factory Preset to 50 PSI

**Does not include an internal check valve

Model VS3085LT, TVS3085LT

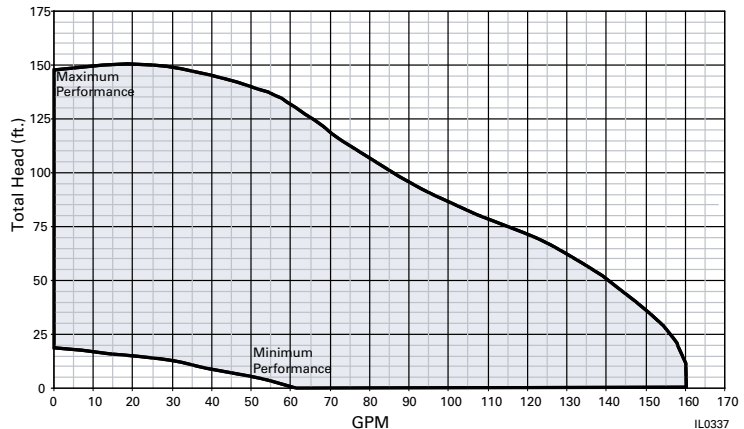

Controls purchased separately. . .
One Year Limited Warranty

Package Systems. . .
Pump End and Motor: 5 Year Limited Warranty
Drive: 3 Year Limited Warranty



**“LT” System
less tank**

VS PACKAGE		VS DRIVE		PUMP END			MOTOR		SWITCH/ TRANSDUCER
MODEL	GPM	MODEL	GPM	DESIGN	PART #	STAGES	PART #	HP	
VS1507LT TVS1507LT	7	VS15 TVS15	07	SS	4F07S07	14	M137458	1.5	024545 024586*
VS1510LT TVS1510LT	10	VS15 TVS15	10	SS	4F10S07	12	M137458	1.5	024545 024586*
VS1519LT TVS1519LT	19	VS15 TVS15	19	SS	4F19S10	9	M137458	1.5	024545 024586*
VS1527LT TVS1527LT	27	VS15 TVS15	27	SS	4F27S10	7	M137458	1.5	024545 024586*
VS2007LT TVS2007LT	7	VS20 TVS20	07	SS	4F07S10	18	M137462	2	024545 024586*
VS2010LT TVS2010LT	10	VS20 TVS20	10	SS	4F10S10	15	M137462	2	024545 024586*
VS2019LT TVS2019LT	19	VS20 TVS20	19	SS	4F19S15	12	M137462	2	024545 024586*
VS2027LT TVS2027LT	27	VS20 TVS20	27	SS	4F27S15	10	M137462	2	024545 024586*
VS2035LT TVS2035LT	35	VS20 TVS20	35	SS	4F35S10	4	M137462	2	024545 024586*
VS3007LT TVS3007LT	7	VS30 TVS30	07	SS	4F07S15	24	M139424	3	024545 024586*
VS3010LT TVS3010LT	10	VS30 TVS30	10	SS	4F10S15	20	M139424	3	024545 024586*
VS3019LT TVS3019LT	19	VS30 TVS30	19	SS	4F19S20	16	M139424	3	024545 024586*
VS3027LT TVS3027LT	27	VS30 TVS30	27	SS	4F27S20	12	M139424	3	024545 024586*
VS3035LT TVS3035LT	35	VS30 TVS30	35	SS	4F35S15	5	M139424	3	024545 024586*
VS3055LT TVS3055LT	55	VS30 TVS30	55	SS	4F55S15	4	M139424	3	024545 024586*
VS3085LT TVS3085LT	85	VS30 TVS30	85	SS	CP15085RP	3	M139424	3	024545 024586*

*024586 - Factory installed pressure transducer kit (0-100PSI).

Optional 0-300PSI pressure transducer kit available (P/N 024587)

All complete Commander® Pro Packages carry a 5 year limited warranty on pump & motor, and 3 year limited warranty on control.

For models with pressure transducer, add a “T” prefix to the model, i.e. TVS1507LT

Accessories

Part Number	Description
024600	Z Control Gateway - Allows for wireless connectivity & real time alerts
024532	Pest Control Kit to keep insects and pests from nesting in drive

DOE Compliance

PUMP MODEL	Impeller Dia.	P.E.I.v.l.
(T) VS2035	3.072"	0.59
(T) VS3035	3.072"	0.53
(T) VS3055	3.075"	0.56
(T) VS3085	3.070"	0.61



FW1850
1020
Supersedes
0319

STAY CONNECTED TO THE JOB SITE ... WITH GLOBAL VFD MONITORING

- Connects to Commander Pro VS Controller
- Push-button simple
- Restore service remotely from anywhere an internet connection is available
- Diagnose problems before arrival and solve issues in record time
- Call customers before they are aware of potential problems
- Sends you and your customers email or text notifications



P/N 024600

Product Includes:

- Gateway Z Controller
- Strain relief
- 7 Ft. connection wire
- Power supply
- Quick start guide

Applications Include:

- Turf Irrigation
- Residential
- Agriculture
- Livestock Production
- Industrial
- Municipal



CONSTANT PRESSURE CONTROLS

FW2147
0620
Supersedes
NEW

Artesian Drive® For Centrifugal Pump Applications

Artesian Drive® is a line of custom programmed Variable Frequency Drives (VFD) that enhance the performance of standard centrifugal pumps. When applied correctly to three phase motor driven pumps, the Artesian Drive® eliminates pressure cycling associated with conventional pressure switch controlled water pumping systems and provides a constant output pressure by increasing or decreasing motor speed, based upon demand. Artesian Drive® is factory programmed for F&W centrifugal pumps to provide optimum performance and motor protection. The Artesian® Drive can be used with other pump brands, provided the pump is powered by a three phase motor that does not exceed the maximum current output rating of the drive.

**NEMA 4
Enclosures**



INCLUDED ITEMS

- Factory programmed variable frequency drive
- NEMA 4 enclosure
- Pressure sensor, preset at 50 PSI
- Sensor adjustment tool
- Sensor cable (10 ft.)

Specifications

FEATURES

- Pre-programmed Drives: No need for field technician to program the drive at the site
 - Drives are available for any 1 thru 15 HP centrifugal pump that is powered by a three phase motor
 - Drives up to 3 HP permit the use of widely available 230 volt, single phase power source
 - Constant water pressure with a wide range of settings (15 - 95 PSI)*
 - Pressure is easily adjusted with a 7/32" allen wrench
 - Works with a small pressure tank or a larger tank, already in place
 - No in-rush current at startup
 - Soft start reduces mechanical/electrical stress, prolonging pump and motor life
 - Built-in protection and diagnostics
 - Motor overload
 - Locked or bound pump - with auto reversing torque
 - Low line voltage
 - Short circuit
 - High voltage / lightning protection
 - Dry run conditions, using intelligent load monitoring
 - Overheated drive with automatic reset
- *NOTE: The maximum obtainable system pressure is limited by the performance of the pump installed.

DRIVE SPECIFICATIONS AND DIMENSIONS

	AD070059	AD096074	AD096096	AD150145	AD420210	AD180145	AD220210	AD280280	AD420410	
Input from power source	Voltage		180-264 VAC Single Phase				180-264 VAC Three Phase			
	Frequency	50/60 Hz								
	Current (Max)	13.9 A	19.5 A	19.5 A	36.4 A	55.8 A	18.8 A	29.1 A	36.4 A	55.8 A
"Output to Motor (Three Phase)"	Voltage		Voltage Automatically Adjusts with Frequency (0 thru 230 VAC)							
	Frequency Range	30-60 Hz								
	Current Programed	5.9 A	7.4 A	9.8 A	14.5 A	21.0 A	14.5 A	20.0 A	28.0 A	41.0 A
	Current Max	7.0 A	11.0 A	11.0 A	15.0 A	23.0 A	18.0 A	23.0 A	30.0 A	46.0 A
For Use With	Motor	Standard 60Hz Pump & 230 V 3-Phase Motor Combination								
	Reference HP Rating*	1.5	2	3	5	7.5	5	7.5	10	15
Pressure Setting	Factory preset	50 PSI								
	Range	15-95 PSI								
Operating Conditions	"Operating Temperature (at 230V Input)"	"-10°C to 40°C (-15°F to 104°F)"			"-10°C to 50°C (-15°F to 122°F)"		"-10°C to 40°C (-15°F to 104°F)"		"-10°C to 50°C (-15°F to 122°F)"	
	Relative Humidity	Max 95% non-condensing								
	Enclosure Rating	IP66	IP66	IP66	IP55	IP55	IP66	IP55	IP55	IP55
Physical Characteristics	Controller Size (inches)	7.4 x 10.2 x 9.5			6.8 x 17.8 x 9.5		8.3 x 12.2 x 10.5		6.8 x 17.8 x 9.5	
	Weight	10.6 lbs.	10.6 lbs.	10.6 lbs.	25.4 lbs.	25.4 lbs.	16.1 lbs.	25.4 lbs.	25.4 lbs.	25.4 lbs.

TYPICAL INSTALLATION

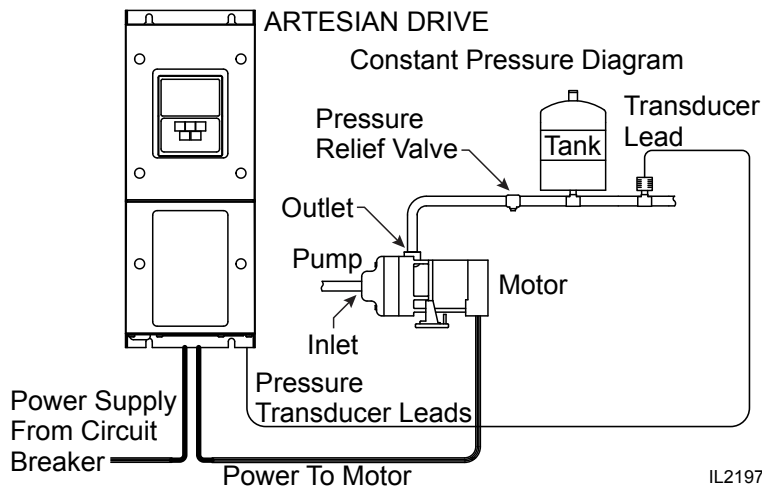

VARIABLE SPEED DRIVE PACKAGES

FW1253
1219
Supersedes
0618

Artesian Drive® Packages for Centrifugal Applications

- Energy efficient - conserves electricity
- Maintains consistent pressure for multiple sprinkler zone applications
- Saves water with fully adjustable pressure sensor — eliminates water fluctuation for consistent zone spray from 30 to 85 PSI
- Factory tested and preset to exact engineering specifications
- Soft start/stop technology extends pump life and reduces water hammer

**NEMA 4
Enclosure**



2 HP, 3 HP, 5 HP and 7-1/2 HP

Three phase w/single phase incoming

Specifications

Model	Description	System Includes		
		Pump	Drive	Tank
ADS101C203	2 HP 3 Phase with 1 phase incoming	CJ101C203	AD096074	132661 AT44
ADS101C303	3 HP 3 Phase with 1 phase incoming	CJ101C303	AD096096	132661 AT44
ADS22253	5 HP 3 Phase with 1 phase incoming	C22253	AD150145	132661 AT44
ADS22273	7.5 HP 3 Phase with 3 phase incoming	C22273	AD220210	132661 AT44

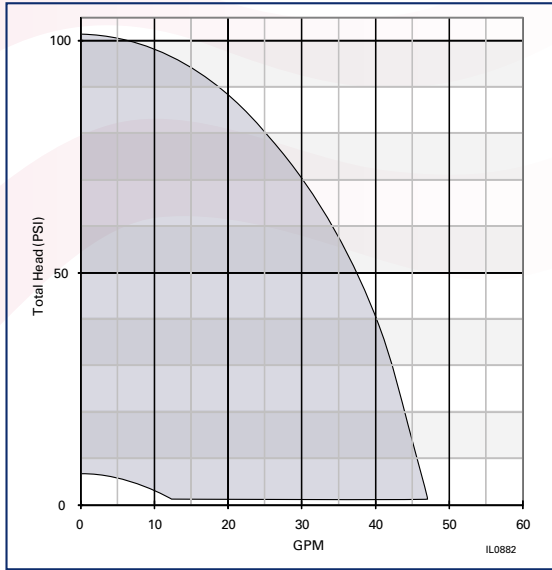

Model: ADS101C203 2 HP

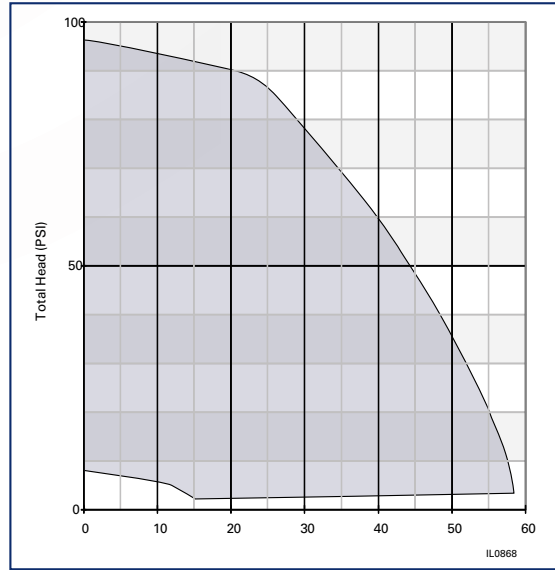

Model: ADS101C303 3 HP

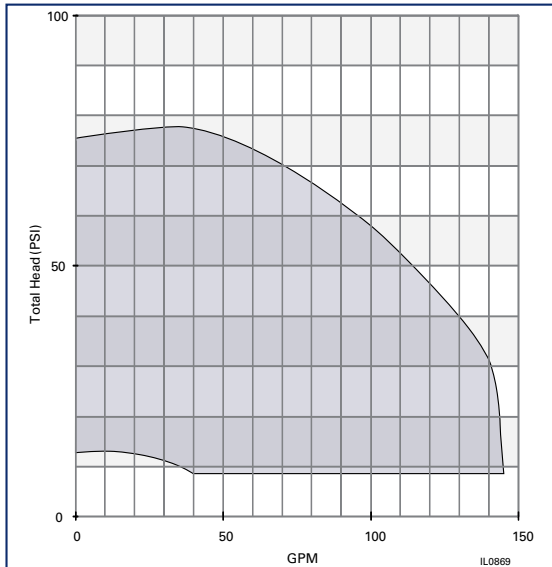

Model: ADS22253 5 HP

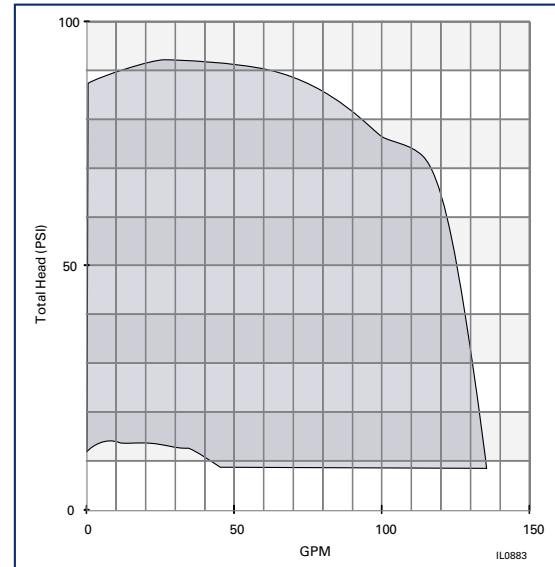

Model: ADS22273 7.5 HP

Constant Pressure Pumping Stations



CONSTANT PRESSURE PUMPING STATIONS

FW1327
1120
Supersedes
0618

**Golf Course
Irrigation**



**Poultry
Operations**



Nurseries



**Commercial
Kitchens**



Artesian Drive[®] Deliver Flow and Pressure Where You Want It.

Artesian Drive[®] pumping stations adapt to your changing flow requirements, using a pump control system to deliver constant pressure at any flow required.

Significant energy savings from variable speed drives make constant speed pumps obsolete.

System dimensions 26" W x 37" L x 32" H



ADW2W31, ADW2W51,
ADW2W71, ADW2W73 &
ADW2W53



3 HP, 5 HP and 7-1/2 HP

Single or Three Phase

Features and Benefits

SYSTEMS INCLUDE

1. Artesian Drive® variable speed controller drive assembly can rotate 90° for flexibility
2. Centrifugal pump with brass impellers and 'Power Plus' motor
3. Air-E-Tainer® diaphragm tank
4. Thermal sensor (not shown)
5. Sealtight conduit
6. 2" Stainless steel manifold for gauge, transducer and hose bib
7. 3 Phase output to motor
8. 2" brass outlet check valve
9. Premium liquid filled gauge
10. 'Powder-coated tough' skid
11. Pressure transducer
12. Hose bib

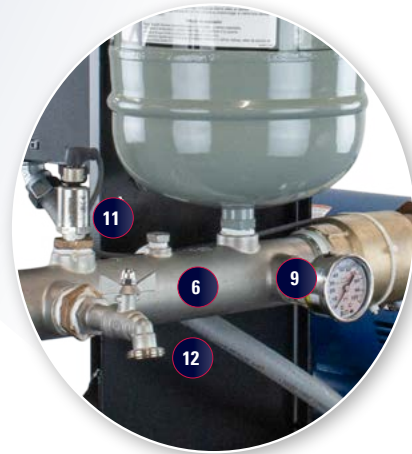

- Artesian Drive® constant pressure pumping stations provide constant water pressures
- Pre-plumbed, pre-wired, pre-programmed and pressure tested. Typical installation time takes less than 1 hour
- Models available up to 145 gallons per minute in 3 HP, 5 HP, and 7-1/2 HP
- Variable frequency drive operates on 230 volt single or three phase power – With three phase output to motor
- Advanced 'on board' diagnostics and pump protection
- Energy efficient – uses significantly less electricity than conventional centrifugal pump applications
- 3" suction with 2" discharge for easy installation
- Includes check valve, gauges and unions for easy serviceability
- 'Powder Coated Tough' skid, panel, and supports to resist rust and corrosion. Efficient in size - Fits through any 27" access door

Performance

PERFORMANCE SPECIFICATIONS

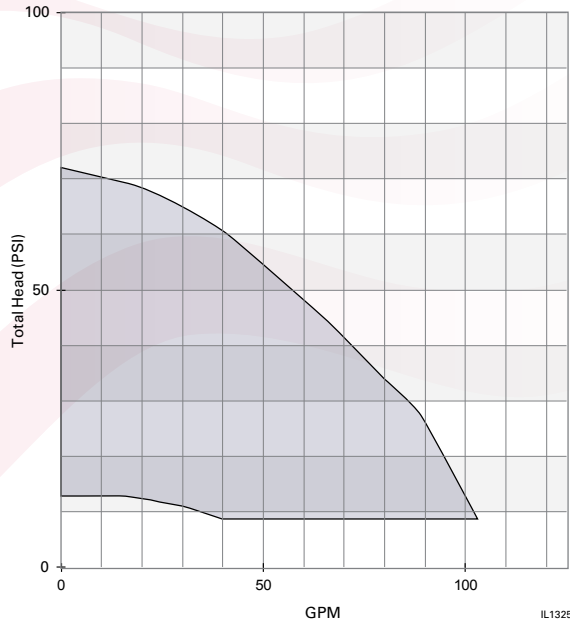

ADW2W31
3 HP Single Phase

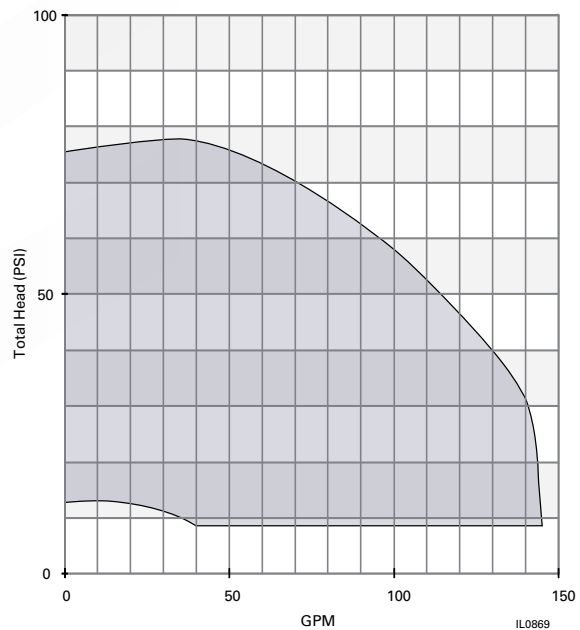

ADW2W51
5 HP Single Phase
ADW2W53E
5 HP Three Phase

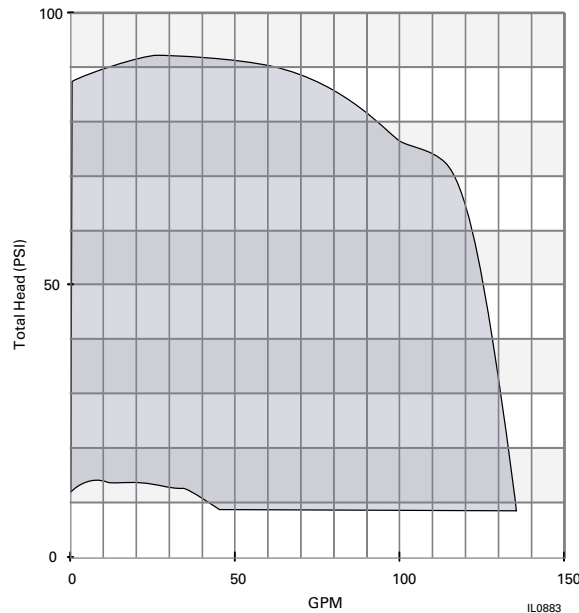

ADW2W71
7-1/2 HP Single Phase,
ADW2W73
7-1/2 HP Three Phase

Artesian® Drive Constant Pressure Pumping Stations

Artesian Drive® Standard Controls



- Artesian Drive® Variable Speed Controller for constant pressure
- Pre-programmed Drives: No need for field technician to program the drive at the site
- Constant water pressure with a wide range of settings (30 - 80 PSI)
- Eliminates in-rush surge current at startup
- Soft start reduces mechanical/ electrical stress, prolonging pump and motor life
- Factory programmed variable speed drive unit
- Pressure transducer, preset at 50 PSI
- Built-in protection and diagnostics protect against:
 - › Motor overload
 - › Low line voltage
 - › Short circuit
 - › High voltage / lightning protection
 - › Dry run conditions, using intelligent load monitoring
 - › Overheated drive with automatic reset

F&W Artesian Drive® pumping stations are fully tested and preset. Just add water and power up system. No complicated startup procedures, special training, or expensive on-site technicians needed.

Systems are ideal for municipalities, golf courses, nurseries, industrial plants and much more. All benefit from the easy installation and years of service from an Artesian Drive® pumping station.



Horizontal Jet Pumps 1/3 - 1-1/2 HP



FW0180
0221
Supersedes
1120

1/3 - 1-1/2 HP

Whether operating as a shallow well or deep well pump, count on F & W's versatile, powerful jet pumps to deliver more water at full city pressures.

These pumps provide higher single stage capacities and pressures; depths to 150 feet, capacities to 1800 GPH and as much as 90 pound pressure.



EK, CPH, CPJS, CPJ, EK TANK SYSTEMS



Higher single-stage capacities and pressures

Depths to 150 ft.

Up to 1800 GPH with up to 90 PSI

“Service Plus” means top reliability plus quick access to all electrical components.

Routine maintenance is simplified through the convenient mounting of electrical components. Removal of the rear access cover exposes components for fast replacement. Spade connectors enable quick hookup and voltage change.

Rear access cover

Directs ventilating air over the windings and bearings, and away from the switch mechanism. All electrical components are protected from dirt, dust and insects.

Quality-wound double insulated stator

Uses nylon over coated wire with an additional varnish dip to insure against moisture penetration. Class B wire insulation rated for 266°F.

Permanently lubricated ball bearings

Located on each end of the motor insuring alignment of the dynamically balanced rotor for smooth operation and extended motor life.

Fully enclosed transfer switch

Mounted on a UL recognized thermo-set plastic board utilizes spark quenching and extra large silver cadmium oxide contact points.

Patented governor

Features an advanced simplified design, using a stainless steel compression spring to insure proper motor RPM before switching from start to run windings.

Zinc clad steel shell and cooling fan

Resist corrosion and dissipate motor heat.

Automatic overload

Senses both start and run winding heat to ensure complete winding protection.

“Service Plus” motors

Manufactured by Flint & Walling, Inc. in Kendallville, IN, USA—An industry exclusive among jet pump manufacturers.

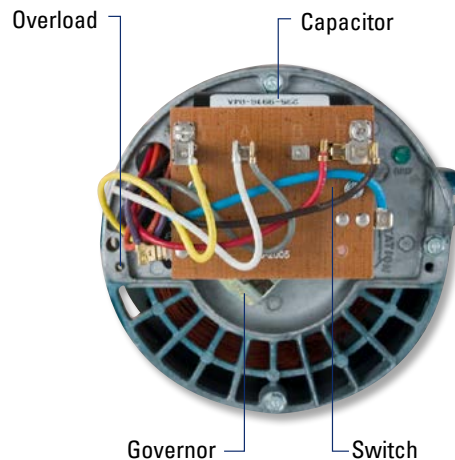
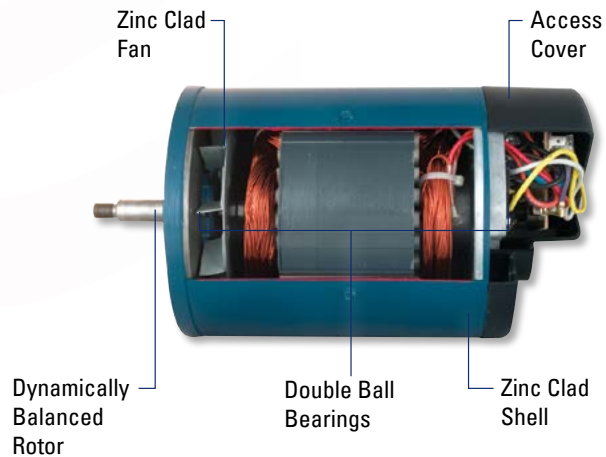

EK, CPJ, CPH Product Features

High tensile gray iron pump bodies

Large water cavities provide fast, easy priming. Separate priming ports enable quick water fill and the fast evacuation of air. Separate 1/4" tappings are provided for the convenient mounting of pressure/vacuum gauges and the pressure switch, and for pump draining.

Buna-n Square cut ring

Reusable — provides a positive seal between the pump case and motor bracket.

Molded diffusers

Corrosion and abrasion resistant, provide precision alignment with the impeller for maximum performance. The snap-in diffuser design uses no bolts and is held in place by compression.

Impellers —

Precision balanced, these impellers are ultra-smooth for high efficiency. 1/3 through 1 HP CPJ, CPH, and EK models feature molded thermoplastic impellers. 1-1/2 HP CPJ models feature brass impellers.

Pipe plugs and priming plugs

Coated with a non-hardening, non-toxic, non-corrosive material which allows for easy removal even after the pump has been in service for years.

Standard shaft seal

Silicon carbide face is self-adjusting throughout the seal life. One size fits all models.

CPH and EK Patented uni-frame motor bracket

Unique to the water systems industry — designed to accept any NEMA J motor if motor replacement is ever necessary.

Automatic overload

Senses both start and run winding heat to ensure complete winding protection.

CPJ models

Feature NEMA J motors. All motors are dual voltage, capacitor start with automatic thermal overload protection.

EK SHALLOW WELL JET PUMPS - 1/2, 3/4 and 1 HP

Includes: Pump, Motor, Pressure Switch and Ejector.

NOTE: EK05S and EK07S feature built-in ejector - no assembly required. EK10S ejector requires assembly.



Product may not be exactly as shown

EK SHALLOW WELL CAPACITIES

Model	HP	Suction Lift. Ft.	Discharge Pressures (PSI)				Shut Off Pressure @ 0 Lift (PSI)	Suction & Discharge	Pressure Switch Setting - PSI	Pump Shipping Weight
			20	30	40	50				
CAPACITY - U.S. GALLONS PER MINUTE										
EK05S	1/2	5	10.5	9.5	5.8	4.0	60	1-1/4" x 3/4"	20-40	40
		15	7.6	7.3	4.5	2.5				
		25	4.5	4.2	3.5	2.0				
EK07S	3/4	5	15.5	15.0	10.0	5.8	65	1-1/4" x 3/4"	30-50	41
		15	11.9	11.7	9.1	3.8				
		25	6.0	5.8	5.2	2.0				
EK10S	1	5	20.0	20.0	19.5	18.3	65	1-1/4" x 1"	30-50	51
		15	15.8	15.5	15.0	14.5				
		25	10.0	9.7	9.5	9.0				

Maximum Pump Case Pressure = 150 PSI

CPHS SERIES - 1/2, 3/4 and 1 HP

Includes: pump, motor, pressure switch and shallow well ejector.



CPJS SERIES - 1/3, 1/2, 3/4, 1 and 1-1/2 HP

Includes: pump, motor, pressure switch and shallow well ejector.

Product may not be exactly as shown



CPJS AND CPHS SHALLOW WELL PERFORMANCE WITH SHALLOW WELL EJECTORS



SW Single Pipe Shallow Well Ejector

Model No.	HP	Ejector* Assembly	Suction Lift Ft.	Discharge Pressures (PSI)					Suction & Discharge	Pressure Switch Setting	Shut Off Pressure PSI	Pump Shipping Weight
				20	30	40	50	60				
				CAPACITY - U.S. GALLONS PER MINUTE								
CPJ03SB	1/3	SW03E-1626	5	11.3	10.7	9.5	6.7	1-1/4" X 3/4"	30-50	74	49	
			15	8.7	8.5	7.8	5.3					
			25	5.3	5.3	5.2	4.2					
CPJ05SB CPH05S	1/2	SW05E-1630	5	17.2	16.8	14.8	10.0	1-1/4" X 3/4"	30-50	69	50	
			15	12.8	12.7	12.2	7.7					
			25	7.7	7.5	7.2	5.3					
CPJ07SB CPH07S	3/4	SW07E-1432	5	19.8	19.5	19.2	18.0	1-1/4" X 1"	30-50	65	58	
			15	15.5	15.2	14.8	14.2					
			25	9.8	9.5	9.3	8.8					
CPJ10SB CPH10S	1	SW10E-1334	5	23.7	23.5	23.3	23.0	1-1/4" X 1"	30-50	70	62	
			15	18.3	18.3	18.2	18.0					
			25	11.7	11.7	11.5	11.3					
CPJ15S	1-1/2	SW15E-1238	5	30.0	29.8	29.8	29.8	1-1/4" X 1"	30-50	77	72	
			15	24.0	23.8	23.7	23.5					
			25	15.0	15.0	15.0	14.8					

* Ejector assembly included
Maximum Pump Case Pressure = 150 PSI

CPH and CPJ Series Jet Pumps



CPH SERIES - 1/2, 3/4 and 1 HP

Includes: pump, motor and pressure switch. Order ejector, control package and pressure gauge separately.

*Add "R" to end of model number to include 134349 control package with pump.



134349 Control Package*

Order Separately for Deep Well Applications.

CPJ SERIES - 1/2, 3/4, 1 and 1-1/2 HP

Includes: pump, motor, pressure switch and pressure regulator. Order ejector and pressure gauge separately.

Product may not be exactly as shown



See pages 6 & 7 for performance charts on the following models:

- | | |
|---------|---------|
| CPJ05B | CPJ10B |
| CPH05 | CPH10 |
| CPH05R† | CPH10R† |
| CPJ07B | CPJ15 |
| CPH07 | |
| CPH07R† | |

For Shallow or Deep Well Applications

- Dual voltage 115/230, NEMA 56 frame motor
- Pressure switch included
- Purchase ejectors separately (see chart).
- Deepwell applications require 134349 flow control package. Purchase separately if needed.
- 1 year limited warranty



Models EK05, EK07 and EK10



EK SERIES

EK05, EK07, EK10 Performance

Pump Model No. and Motor HP	Ejector Model No.	Discharge Pressure*	Vertical Distance to Water in Feet												DW Minimum Operating Pressure PSI			
			5	15	25	20	30	40	50	60	70	80	90	100		110		
			Shallow Well Ejector Attached to Pump			Deep Well Ejector in 4" ID well or Larger												
EK05 1/2 HP	SW03E-1626	20 40	11.3 9.5	8.7 7.8	5.3 5.2													--
	DW40E-1726 DP30C-1726†	20 40	10.0 8.3	7.5 7.2	4.7 4.3	10.8 6.0	8.3 4.7	7.0 3.8										20
	DW40E-1622 DP30C-1622†	20 40	6.5 6.0	5.7 5.2	4.2 3.8		7.0 4.3	6.2 3.5	5.5 3.0	4.7 2.3								24
EK07 3/4 HP	SW05E-1630	30 50	17.0 10.0	12.9 8.0	7.8 5.5													
	DW40E-1730 DP30C-1730†	30 50	14.5 10.0	11.3 8.3	7.2 6.5	12.5 5.5	10.8 3.7	8.7 2.0										
	DW40E-1828 DP30C-1828†	30 50	11.5 10.2	8.8 5.5	5.3 5.2	11.2 6.7	10.8 5.5	8.8 3.8	7.2 2.3	5.0 1.0								
	DW40E-1622 DP30C-1622†	30 50						6.7 4.3	6.0 3.8	5.3 3.3	4.3 2.5	3.3 1.7	2.5 1.0					
EK10 1 HP	SW07E-1432	30 50	19.5 18.0	15.2 14.2	9.5 8.8													--
	DW40E-1630 DP30C-1630†	30 50	15.7 15.0	12.3 12.2	8.3 8.0	16.7 12.5	14.2 8.3	12.2 5.0	8.3 2.5									35-37
	DW40E-1726 DP30C-1726†	30 50	10.0 9.5	7.5 7.3	4.7 4.3	11.7 9.2	11.7 9.2	11.5 8.2	10.3 7.0	9.0 5.7	7.7 4.3	6.2 3.2	4.8 1.7					37-39
	DW40E-1520 DP30C-1520†	30 50										5.0 3.7	4.8 3.3	4.3 3.0	3.7 2.7			39

DP30 Ejectors include foot valve
Maximum Pump Case Pressure = 150 PSI

* Suction & pressure pipe tapping 1-1/4" x 1" -- reduced pipe sizes will result in lower than published performance

†Not for sale in states following Proposition 65 or AB1953

CPJ and CPH Convertible Ejectors



CPJ AND CPH SHALLOW WELL CAPACITIES WITH CONVERTIBLE EJECTOR



Model No.	HP	Ejector Assembly	Suct. Lift Ft.	Discharge Pressures (PSI)								Suction & Discharge	Pressure Switch Setting	Shut Off Pressure PSI	Pump Ship Weight
				20	30	40	50	60	70	80	90				
				CAPACITY - U.S. GALLONS PER MINUTE											
CPJ05B CPH05 CPH05R†	1/2	DW40E-1730	5	14.8	14.5	13.2	10.0	6.7				1-1/4" X 3/4"	30-50	76	46
			15	11.8	11.3	11.2	8.3	5.0						72	
CPJ07B CPH07 CPH07R†	3/4	DW40E-1630	5	16.0	15.7	15.5	15.0	10.3				1-1/4" X 1"	30-50	75	56
			15	12.5	12.3	12.2	7.0							72	
CPJ10B CPH10 CPH10R†	1	DW40E-1634	5	20.8	20.8	20.5	20.3	15.8				1-1/4" X 1"	30-50	80	58
			15	16.7	16.7	16.3	16.2	13.0						75	
CPJ15	1-1/2	DW40E-1736	5	23.8	23.3	23.3	23.0	18.7	13.8	8.3		1-1/4" x 1"	30-50	93	66
			15	18.0	17.8	17.5	17.3	16.3	11.7	6.0				88	
			25	11.0	10.7	10.7	10.5	10.3	8.3	2.0				82	

†"R" models include pressure switch and 134349 control package. Order ejector separately.
Maximum Pump Case Pressure = 150 PSI

NOTE: The DW40E ejector can be bolted to the pump as a shallow well ejector or submerged in casing as a convertible deep well ejector.

CPJ AND CPH DEEP WELL CAPACITIES WITH TWO-PIPE CONVERTIBLE EJECTOR



Model No.	HP	Ejector Assembly	Min. Oper. Press.	Disch. Press. PSI	Vertical Distance to Water in Feet														Press. Switch Setting	Pump Ship Wt.
					20	30	40	50	60	70	80	90	100	110	120	130	140			
					CAPACITY - U.S. GALLONS PER MINUTE															
CPJ05B CPH05	1/2	DW40E-1730	25	30	12.5	10.8	8.7											30-50	46	
				50	5.5	3.7	2.0													
				Shut Off	67	63	57													
CPJ07B CPH07	3/4	DW40E-1630	35-37	30	16.7	14.2	12.2	8.3										30-50	56	
				50	12.5	8.3	5.0	2.5												
				Shut Off	75	70	65	59												
CPJ10B CPH10	1	DW40E-1634	46	30	19.2	15.0	11.7	8.3										30-50	58	
				50	10.0	7.5	5.0	2.5												
				Shut Off	71	66	62	57												
CPJ15	1-1/2	DW40E-1728	50-53	30	13.0	13.0	12.8	12.5	10.5	9.0	7.5	5.8	4.0					30-50	66	
				50	12.0	12.0	10.8	9.5	7.8	6.2	5.0	3.5	2.0							
				Shut Off	110	105	99	93	87	81	76	70	64							
CPJ15	1-1/2	DW40E-1520	46-47	30							5.0	4.5	3.8	3.5	2.7		30-50	66		
				50						5.2	4.7	4.2	3.7	3.2	2.7	2.2				
				Shut Off						130	123	117	110	104	98	92				
CPJ15	1-1/2	DW40E-1736	46-52	30	21.7	17.5	13.3	10.0	6.7								30-50	66		
				50	15.0	11.7	8.3	5.0	2.7											
				Shut Off	80	76	71	65	60											
CPJ15	1-1/2	DW40E-1728	50-53	30													30-50	66		
				50																
				Shut Off																
CPJ15	1-1/2	DW40E-1520	52-54	30													30-50	66		
				50																
				Shut Off																

Maximum Pump Case Pressure = 150 PSI, * Suction & pressure pipe tapping 1-1/4" x 1"

CPJ AND CPH DEEP WELL CAPACITIES WITH 2" SINGLE PIPE EJECTOR



**Two Inch
Single Pipe
Ejector**

Model No.	HP	Ejector Assembly	Min. Oper. Press.	Disch. Press. PSI	Vertical Distance to Water in Feet															Press. Switch Setting	Pump Ship Wt.
					20	30	40	50	60	70	80	90	100	110	120	130	140	150			
					CAPACITY - U.S. GALLONS PER MINUTE																
CPJ05B CPH05	1/2	SP20BL-1730†	27	30 50 Shut Off	10.8 5.0 65	9.2 3.3 60	7.5 1.7 55												30-50	46 38	
		SP20BL-1828†	27-30	30 50 Shut Off	11.7 6.7 76	9.7 4.7 68	7.5 2.8 60	5.8 1.2 55	3.8										30-50		
		SP20BL-1622†	31	30 50 Shut Off			6.2 4.2 90	5.8 2.8 83	5.0 2.8 76	4.0 2.2 70	3.3 1.3 61	2.3 0.3 55							30-50		
CPJ07B CPH07	3/4	SP20BL-1630†	39	30 50 Shut Off	16.2 11.7 75	13.7 7.5 70	10.8 5.0 65	7.5 1.7 55											30-50	56	
		SP20BL-1726†	39	30 50 Shut Off	11.0 8.3 91	11.0 7.5 87	9.7 6.7 82	9.5 5.3 78	7.2 4.2 72	5.8 2.8 66	3.3 1.8 62							30-50			
		SP20BL-1520†	40	30 50 Shut Off					5.3 4.2 108	5.0 3.8 100	4.5 3.3 92	3.8 2.7 84	3.3 2.2 77	2.8 1.7 70					30-50		
CPJ10B CPH10	1	SP20BL-1634†	44-47	30 50 Shut Off	16.7 10.0 71	15.0 7.5 66	11.7 4.7 61	8.3 2.0 55											30-50	49	
		SP20BL-1828†	44-47	30 50 Shut Off	11.7 11.0 104	11.7 9.8 98	11.2 8.8 92	10.0 7.3 86	8.3 6.0 80	7.0 4.5 72	5.5 3.3 67	3.8 1.8 61	2.2 0.5 55					30-50			
		SP20BL-1520†	45-47	30 50 Shut Off					5.3 5.0 119	5.3 4.5 113	5.0 4.0 106	4.3 3.5 100	3.7 2.8 94	3.2 2.5 89	2.5 2.0 83	2.0 1.3 78			30-50		
CPJ15	1-1/2	SP20BL-1736†	46-52	30 50 Shut Off	20.0 13.3 80	15.8 10.0 75	12.5 7.5 70	9.7 5.0 65	6.7 2.7 60										30-50	66	
		SP20BL-1728†	51-53	30 50 Shut Off			11.7 10.0 102	11.7 9.0 96	10.0 7.5 90	8.0 5.8 84	6.3 4.3 78	4.8 3.0 71	3.5 1.8 65					30-50			
		SP20BL-1520†	52-55	30 50 Shut Off					5.3 5.3 130	5.3 5.0 125	5.3 4.5 120	4.8 4.2 115	4.2 3.7 110	3.7 3.2 103	3.2 2.7 95	2.7 2.2 88			30-50		

Maximum Pump Case Pressure = 150 PSI †Not for sale in states following Proposition 65 or AB 1953

"EK" SHALLOW WELL TANK MOUNTED SYSTEMS



Model	HP	Tank Type	Approximate Dimensions - Inches			Ship Wt.
			L	W	H	
EK05SAT25H	1/2	Horizontal	24.5	17.25	33.5	76 lbs.
EK07SAT44H	3/4	Horizontal	24.5	17.25	33.5	76 lbs.

For performance specifications, see EK pump page.

Includes: Pump, motor, pressure switch, ejector, pressure tank and connection fittings from pump to tank.

POWER CONVERSION UNIT FOR JET AND CENTRIFUGAL PUMPS

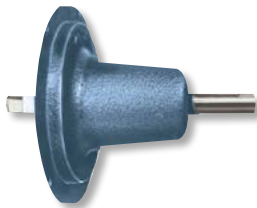

Order No.	Application
122649 NEMA C	Can be used with any jet or centrifugal pump equipped with NEMA C or NEMA J standard electric motors. Gasoline engine or electric motor can be directly coupled with shaft or can be used with belt and pulley. For electric motor used with belt drive, the motor HP should be doubled. The gasoline engine HP should be doubled that of standard motor in either case above.
135458 NEMA J	5/8" diameter steel shaft, mounted in two heavy duty ball bearings, carry all radial and thrust loads.

CONVERTIBLE JET PUMPS WITH POWER CONVERSION UNIT



Model No.	Description	Pressure Control Valve Required†
CPJ05 222	Threaded Shaft	124330
CPJ07 222	Threaded Shaft	132446
CPJ10 222	Threaded Shaft	132446
CPJ15 222	Threaded Shaft	133383

†Pressure control valve required for deep well applications - order separately. Order ejector separately.

CPJ Convertible Jet Pumps fitted with a power conversion unit offer the flexibility of electric motor or gasoline engine drive. Can be belt or direct driven. Power conversion unit features cast iron body and double, heavy duty ball bearings.

SERVICE KITS FOR JET PUMPS



Model No.	Service Kit For:	Kit Contents
148143	1/3 HP CPJ Jet Pumps 1/2 HP EK Jet Pump	Impeller, Diffuser, Rotary Seal, Square Cut Ring, Diffuser Rubber
148141	1/2 HP CPJ & CPH Jet Pumps 3/4 HP EK Jet Pump	
148140	3/4 HP CPJ & CPH Jet Pumps 1 HP EK Jet Pump	
023705	1 HP CPJ, CPH & VPH10 Jet Pumps	

EK SHALLOW WELL JET PUMP TANK MOUNTED SYSTEMS

FW0380
1120
Supersedes
0319



COMPLETE SYSTEM INCLUDES:

- Heavy cast iron CSA approved shallow well jet pump.
- Capacitor start motor with thermal overload protection. Dual voltage motor is factory connected for 115 volts. Spade connectors enable quick voltage change to 230 volt service.
- Horizontal Air-E-Tainer® pre-charged pressure tank with plumbing fitting between pump and tank



EK05SAT25H, EK07SAT44H

Model	HP	Tank Type	Approximate Dimensions - Inches			Ship Weight
			Length	Width	Height	
EK05SAT25H	1/2	Horizontal	24.5	17.25	33.5	76 Lbs.
EK07SAT44H	3/4	Horizontal	24.5	17.25	33.5	76 Lbs.

Model	Suction Lift Ft.	Pressure Switch Setting PSI	Capacities GPM At Discharge Pressure PSIG				Suction & Discharge
			20	30	40	50	
EK05SAT25H 1/2 HP 115/230V	5	30-50	10.5	9.5	5.8	4.0	1-1/4" X 3/4"
	15		7.6	7.3	4.5	2.5	
	25		4.5	4.2	3.5	2.0	
EK07SAT44H 3/4 HP 115/230V	5	20-40	15.5	15.0	10.0	5.8	1-1/4" X 3/4"
	15		11.9	11.7	9.1	3.8	
	25		6.0	5.8	5.2	2.0	

Deep Well Jet Pumps 3/4 - 1-1/2 HP Single & Multi-Stage



DEEP WELL JET PUMPS

FW0185
0920
Supersedes
0319



VA SERIES - Exclusive vacuum operated pressure regulator that automatically adjusts to varying depths and discharge pressures. No manual adjustment necessary.



VS and VPH SERIES - Adjustable automatic pressure regulator provides maximum capacities and pressure at all times.

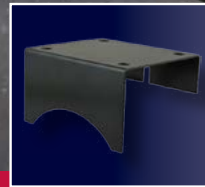

135276A Optional Pump Base For Horizontal Mounting of "VA" and "VS" Series Jet Pumps

3/4 - 2 HP Single & Multi-Stage

- Nema J single phase, 60 HZ, 3450 RPM dual voltage motor, features: quality windings, double ball bearings and overload protection with automatic restart.
- Precision molded impeller and diffuser insures perfect alignment and ultra-smooth passages for high performance and reliability.
- Large one-piece pump case design, pump can be disassembled without disturbing well or discharge pipes.
- Top located priming port and discharge prevents air lock and allows for easy priming.
- Convenient tappings for draining of pump and installation of pressure switch and pressure gauge.



VA Series with exclusive totally automatic pressure regulator



VS Series with adjustable diaphragm pressure regulator



VA, VS and VPH Series



VPH Series with adjustable diaphragm pressure regulator

VA Series Two Stage, 3/4 - 1-1/2 HP

VPH Series Single Stage, 1 HP

VS Series Two Stage 3/4 - 1-1/2 HP

VA, VS & VPH Performance Specifications

V SERIES DEEP WELL PERFORMANCE SPECIFICATIONS																									
MODEL NO. HP STAGES	TWO PIPE EJECTORS		SINGLE PIPE EJECTORS		NOZZLE VENTURI SELECTION	VERTICAL DISTANCE TO WATER IN FEET CAPACITY IN GPM														LB. PUMP DISCH. PRESS					
	CAST IRON	4"	CAST IRON	2"		BRASS	2"	N	V																
										30	40	50	60	70	80	90	100	120	140		160	180	200	220	240
VPH10 1 HP 1 STAGE	DW40E					16	34	15.0	11.7	8.3															
						18	28	13.0	12.8	12.5	10.5	9.0	7.5	5.8	4.0										
						15	20						5.5	5.5	5.0	4.5	3.8	3.5	2.7						
	SP20CL† SP22CL†	SP20BL†	16	34	15.0	11.7	8.2																		
			18	28	11.7	11.2	10.0	8.3	7.0	5.5	3.8	2.2													
			17	24		10.4	9.3	8.2	7.2	6.0	5.0	4.0	3.0												
15	20						5.3	5.3	5.0	4.3	3.7	3.2	2.5	2.0											
VA207P VS207P 3/4 HP 2 STAGE	DW40E					13	26	13.5	12.2	10.5	9.2														
						15	24			9.4	8.7	7.9	7.2	6.3	5.6										
						14	18									4.7	4.5	4.2	3.7	3.0	2.3				
	SP20CL† SP22CL†	SP20BL†	13	26	12.9	11.1	9.3	7.6																	
			15	24			8.1	7.4	6.4	5.4	4.4	3.8													
			14	18									4.3	3.5	2.6										
VA210P VS210P 1 HP 2 STAGE	DW40E					13	28	16.5	14.7	12.5	10.1														
						15	26			12.6	11.3	10.1	8.8	7.5	6.3										
						14	20									6.2	5.5	4.8	4.2	3.5	2.8				
	SP20CL† SP22CL†	SP20BL†	14	28	15.2	12.7	10.1	8.5																	
			15	26			11.1	9.5	8.2	6.8	5.4	4.4													
			14	18									4.3	4.0	3.7										
VA215P VS215P 1-1/2 HP 2 STAGE	DW40E					12	28	17.4	15.6	13.8	11.9														
						15	26			14.3	13.1	11.9	10.8	9.5	8.3										
						14	20									7.3	6.7	6.0	5.4	4.8	4.3	3.6	2.8		
	SP20CL† SP22CL†	SP20BL†	12	28	16.4	14.4	12.4	10.3																	
			15	26			13.0	11.6	10.2	8.8	7.4	6.5													
			14	20									6.3	5.8	4.9	4.0	3.0	2.0							
14	18															3.2	2.8	2.0							

To order complete ejector package, add nozzle and venturi suffix to ejector number (Example SP20BL-1726). For ejector package less nozzle and venturi, use suffix 0000 (Example SP20BL-0000). Complete ejector package includes ejector body, nozzle and venturi plus foot valve. For appropriate well adapter see chart below. All 2" single pipe performance data is based on 1 1/4" drop pipe. If 1" drop pipe is used the performance will be less. Pressure pipe and suction pipe tappings 1 1/4" x 1" discharge tapping 1". †Not for sale in states following Proposition 65 and AB1953

VA and VS SERIES SHALLOW WELL PERFORMANCE SPECIFICATIONS																	
MODEL NO.	HP	SHALLOW WELL EJECTOR ASSEMBLY	SUCTION LIFT FEET	CAPACITIES - GPM AT DISCHARGE PSI							SUCTION & DISCHARGE	PRESSURE SWITCH SETTING	SHUTOFF PRESSURE PSI	SHIPPING WT			
				20	30	40	50	60	70	80					90		
VA207P VS207P	3/4	SW10V-1030	5	16.0	16.0	16.0	14.5	9.5						75	67		
			15	13.5	13.5	13.5	12.3	7.2	2.8				1-1/4" X 1"	30-50		68	
			25	7.5	7.5	7.5	7.2	2.3								64	
VA210P VS210P	1	SW10V-1030	5	16.7	16.7	16.7	16.7	14.3	9.0					80	72		
			15	13.3	13.3	13.3	13.3	11.7	5.0				1-1/4" X 1"	30-50		75	
			25	7.2	7.2	7.2	7.2	6.8								70	
VA215P VS215P	1-1/2	SW15V-1034	5	20.7	20.7	20.7	20.7	20.7	20.3	17.0				96	76		
			15	17.3	17.3	17.3	17.3	17.3	17.2	15.0	11.0			1-1/4" X 1"		30-50	91
			25	9.2	9.2	9.0	9.0	9.0	9.0	6.8						84	

Order shallow well ejector assembly separately.

EJECTOR SPECIFICATIONS AND WELL ADAPTER SELECTION CHART						
EJECTOR ORDER NO.	EJECTOR DESCRIPTION	EJECTOR DROP PIPE TAPPING	WELL SIZE / DROP PIPE	WELL ADAPTER REQUIRED		
				PACKAGE NO.	TYPE	
SP20BL†	2" Brass, Leather	1-1/4" M	2" x 1-1/4"*	129720 129723	Straight Rt. Angle	
SP20CL†	2" Cast Iron, Leather	1" F	2" x 1"	129719 127025	Straight Rt. Angle	
SP22CL†	2" Cast Iron, Leather	1-1/4" M	2" x 1-1/4"	129720 129723	Straight Rt. Angle	

*129205 1-1/4" turned coupling required. Order separately.
†Not for sale in states following Proposition 65 and AB1953

Part No.	Description
022961	Adapter to match Sta-Rite vertical jet pump footprint to F&W "VA", "VS" and "VPH" jet pumps without disturbing existing well plumbing

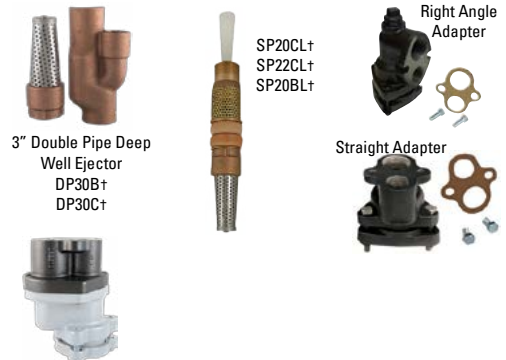



PRESSURE BOOSTER PUMPS

FW0125
1021
Supersedes
1020

PRESSURES TO 200 PSI

The pressure booster pump is designed to increase water pressure from city mains or private water systems.

Applications include pressure cleaning, spray or mist systems, jockey pumps, booster service, reverse osmosis, water circulation and general purpose pumping.



PB SERIES STAINLESS STEEL, POWDER COATED CAST IRON OR CAST IRON

1/3 - 3 HP

60Hz or 50Hz

5, 7, 10, 19, 27, 35, 55 & 85 GPM



††NOTE: Models with TEFC motors are not CSA certified

MATERIAL CONSTRUCTION

Component Description	Stainless Steel Models 5, 7, 10, 19, 27 & 35 GPM 1/3 thru 3 HP	Powder-coated Models 5, 7, 10, 19, 27 & 35 GPM 1/3 thru 3 HP	Cast Iron Models 5, 7, 10, 19, 27 & 35 GPM 1/3 thru 3 HP
Suction and Discharge Casting	304 (CF-8) stainless steel	Powder coated cast iron	Cast Iron
Pump Shell	304 heavy wall stainless steel	304 heavy wall stainless steel	304 heavy wall stainless steel
Staging*	Noryl® impellers and diffusers; type 304 stainless steel floating bearing inserts and acetal diffuser plates	Noryl® impellers and diffusers; type 304 stainless steel floating bearing inserts and acetal diffuser plates	Noryl® impellers and diffusers; type 304 stainless steel floating bearing inserts and acetal diffuser plates
Pump Shaft and Motor Coupling Assembly	304L stainless steel hex shaft with 316 S.S. motor to shaft coupling	304L stainless steel hex shaft with 316 S.S. motor to shaft coupling	304L stainless steel hex shaft with 316 S.S. motor to shaft coupling
Shaft Seal	Carbon-silicon carbide, stainless steel spring, and Viton®	Carbon-silicon carbide, stainless steel spring, and Buna-N	Carbon-silicon carbide, stainless steel spring, and Buna-N
O-Rings	Viton®	Buna N	Buna-N
Motor 	Open drip proof (ODP) and Totally enclosed fan cooled (TEFC) motors available with single or three phase options.		

* Replacement cartridge assembly available for all models. Includes all necessary parts to restore pumps to like-new performance. No special tools required.

Noryl® is a registered trademark of General Electric.

Viton® is a registered trademark of Dupont.

PERFORMANCE SPECIFICATIONS

PRESSURE ADDED - PSI†					10	20	40	60	80	100	120	140	160	180	200	220	Max. Press. PSI	Suction Pipe Tap NPT	Disch. Pipe Tap NPT
Stainless Steel Fitted	Powder-Coated Cast Iron Fitted	Cast Iron Fitted	HP	Stage	Output - Gallons per Minute														
60Hz Models																			
PB0508S031 Δ	PB0508C031	PB0508A031	1/3	8	10.2	9.6	8.3	6.5	4.3								96	3/4"	3/4"
PB0512S051 Δ	PB0512C051	PB0512A051	1/2	12	10.0	9.5	8.3	7.1	6.0	4.0	2.3						132		
PB0516S071 Δ	PB0516C071	PB0516A071	3/4	16	10.2	9.7	9.1	8.3	7.5	6.6	5.8	4.6	3.3				189		
PB0712S071 Δ	PB0712C071	PB0712A071	3/4	12	14.0	13.4	12.2	10.9	9.5	8.9	7.0	4.6					158		
PB1014S101 Δ	PB1014C101	PB1014A101	1	14	*	*	14.5	13.4	12.3	11.2	9.8	8.0	6.0	2.3			183		
PB1016S151 Δ	PB1016C151	PB1016A151	1-1/2	16	*	*	15.0	14.1	13.1	12.1	11.0	9.8	8.2	5.2	2.0		212		
PB1914S201	PB1914C201	PB1914A201	2	14	27.6	27.0	25.7	24.2	22.6	20.8	18.7	16.2	12.9	7.7			190	1"	1"
PB3506S201	PB3506C201	PB3506A201	2	6	48.0	47.0	42.5	35.2	24.0								85		
PB2711S201	PB2711C201	PB2711A201	2	11	*	*	31.5	29.5	27.1	24.2	20.3	13.0					147		
PB3508S301	PB3508C301	PB3508A301	3	8	48.0	47.5	44.0	40.0	35.2	27.5							118		
PB2714S301 ††	PB2714C301 ††	PB2714A301	3	14	*	*	33.0	31.5	29.8	27.9	25.6	22.8	18.9	11.1			187		
PB2717S303A**	-	-	3	17	*	*	*	34.1	32.3	30.5	28.3	25.8	23.1	20.0	16.6	11.4	225		
PB2717S303T**	-	-	3	17	*	*	*	34.1	32.3	30.5	28.3	25.8	23.1	20.0	16.6	11.4	225	2"	2"
-	-	PB5504A201	2	4	77.6	71.5	52.5										55		
-	-	PB5506A301	3	6	77.8	74.4	65.0	51.1	31.9								83		
-	-	PB8504A201	2	4	105.8	90.0	47.0										49		
-	-	PB8505A301	3	5	108.8	98.8	60.0	25.0									60		
50Hz Models																			
PB0508Y031 Δ	PB0508Z031	PB0508X031	1/3	8	7.5	6.8	5.0	2.0									66	3/4"	3/4"
PB0514Y051 Δ	PB0514Z051	PB0514X051	1/2	14	*	7.3	6.4	5.3	4.0	2.1							113		
PB0714Y071 Δ	PB0714Z071	PB0714X071	3/4	14	*	10.9	9.7	8.5	7.0	5.2	2.8						132		
PB1020Y101	PB1020Z101	PB1020X101	1	20	*	13.0	12.2	11.4	10.5	9.5	8.2	6.8	5.0	2.0			183		
PB1022Y101	PB1022Z101	PB1022X101	1	22	*	12.0	12.2	11.4	10.5	9.5	8.4	7.4	6.0	4.3	2.0		203		
PB1023Y101	PB1023Z101	PB1023X101	1	23	*	12.0	12.2	11.4	10.5	9.6	8.6	7.6	6.5	5.1	3.3		213		
PB1920Y151	PB1920Z151	PB1920X151	1-1/2	20	*	22.1	21.0	19.5	18.0	16.1	14.1	11.6	8.3	2.0			182	1"	1"
PB2717Y201	PB2717Z201	PB2717X201	2	17	*	30.8	28.9	26.7	24.1	21.2	18.0	13.5					160		
PB3508Y151	PB3508Z151	PB3508X151	1-1/2	8	*	39.4	33.9	27.0	14.0								84		
PB3514Y301T	PB3514Z301T	PB3514X301T	3	14	*	*	38.5	36.5	32.1	28.1	23.0	14.4					146		

† Example: If PB0508A031 pump is connected to supply line of sufficient capacity, carrying water at 40 PSI, and the output of the pump is held to 8.3 GPM by a gate valve, the pump will add 40 PSI to line pressure for a total output pressure of 80 PSI.

* Operation of pump in this range may result in reduced pump life and/or motor damage.

To keep pump and seal lubricated, a minimum flow of 1.5 GPM must always be maintained through the pump.

** Only available in 3 phase

†† Models marked are also available in 575V, 3 Phase Only.

Motor voltage: Open Drip Proof
 Single Phase 1/3 - 2 HP - 115/230; 3 HP - 230V 60 Hz.
 Three Phase 1/2 - 2 HP - 208-230/460, 50/60Hz.
 Three Phase 3 HP - 208-230/460, 60 HZ
 Three Phase 2 - 3 HP - 575V, 60Hz
 For three phase models, use suffix "3" on the model no.
 Example: PB0512A053

Totally Enclosed Fan Cooled
 Single Phase: 1/2 thru 3 HP - 115/230V 60/50Hz
 Three Phase: 1/2 thru 3 HP - 208/230/460V 60/50Hz

Δ Less than 50% US content

Pressure Booster Pump Performance Curves 3450 RPM 60 Hz



60 Hz PERFORMANCE CURVES

5 GPM

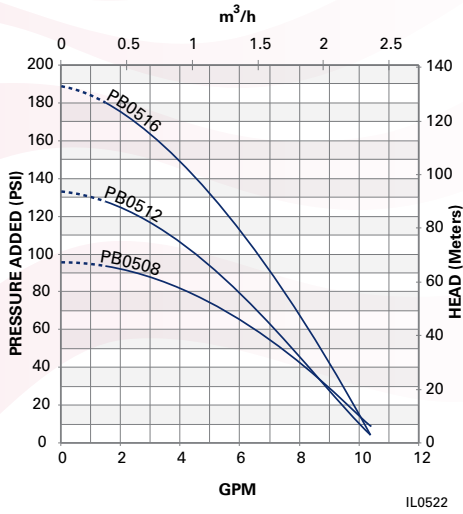

35 GPM

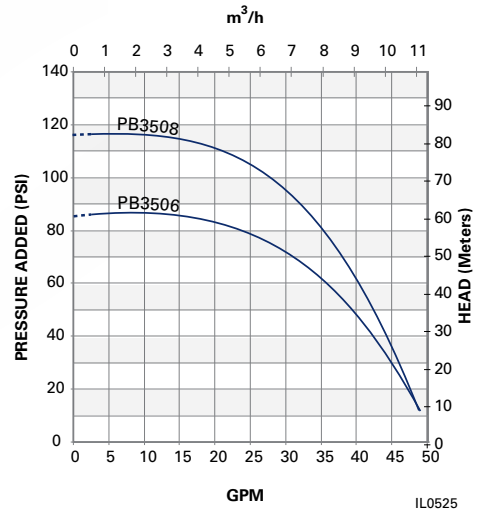

7 and 10 GPM

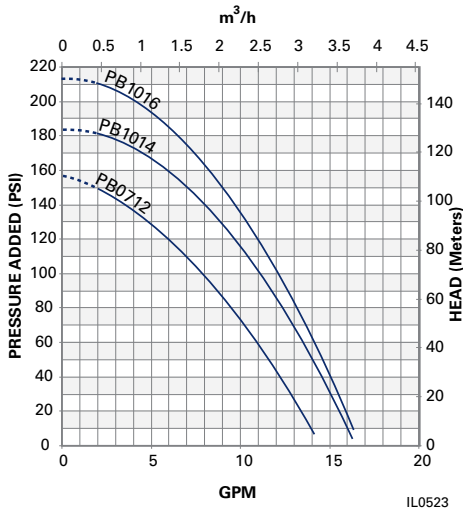

55 & 85 GPM

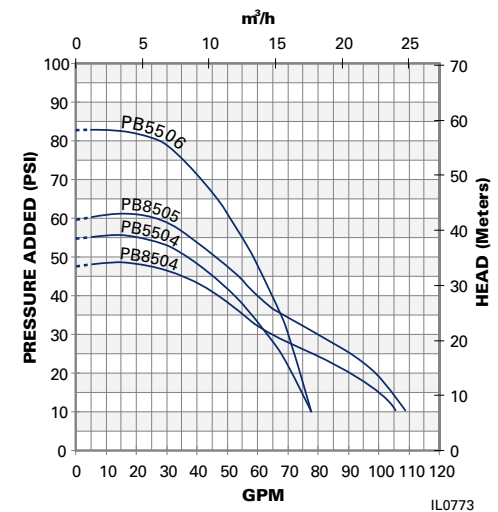

19 & 27 GPM

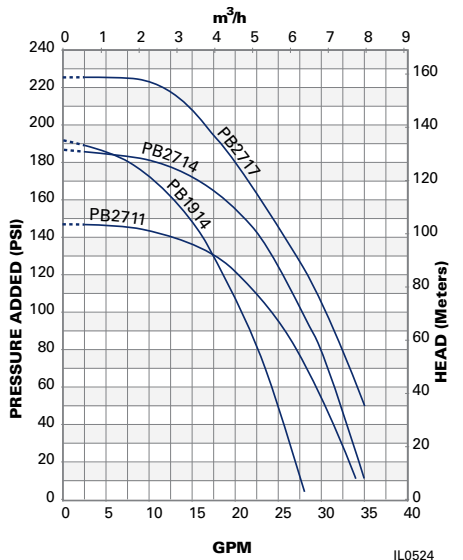

Do not operate pumps in flow range indicated by dotted line.

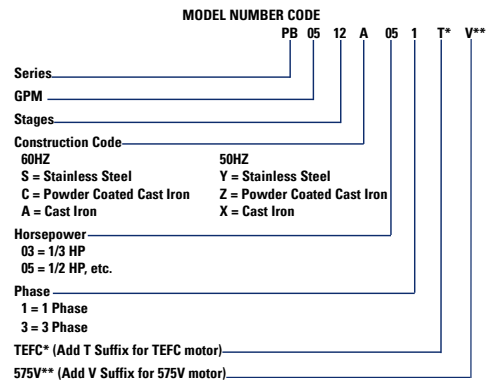

TEFC motors available on powder coated cast iron models and stainless steel models only

50 Hz PERFORMANCE CURVES

5 and 7 GPM

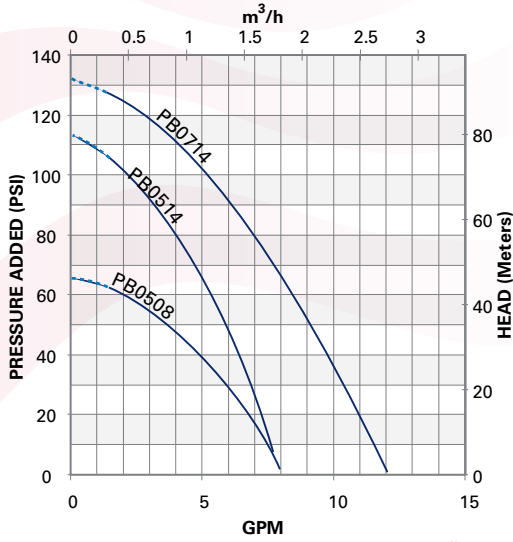

IL0507

10 GPM

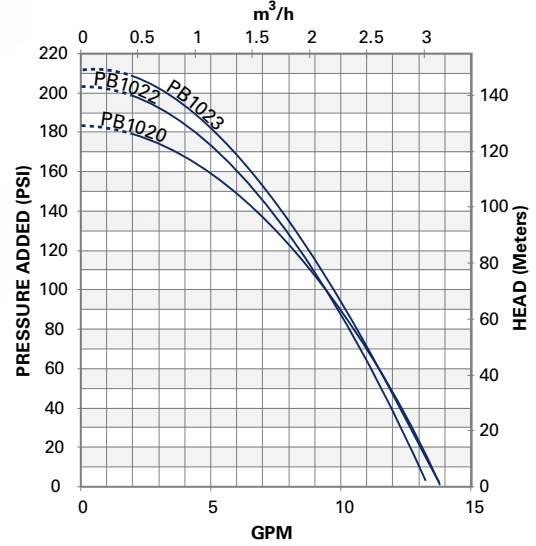

IL0508

19 and 27 GPM

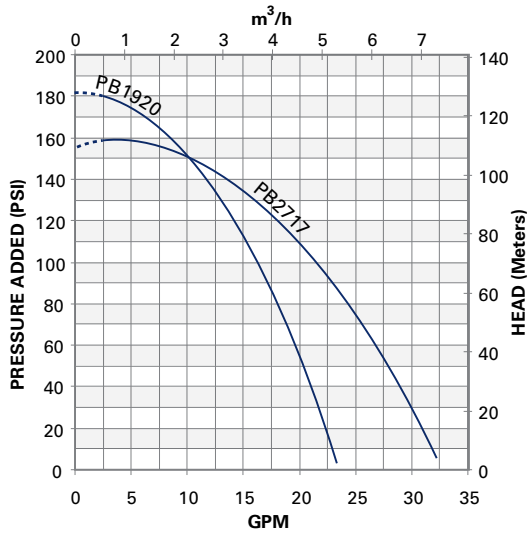

IL0509

35 GPM

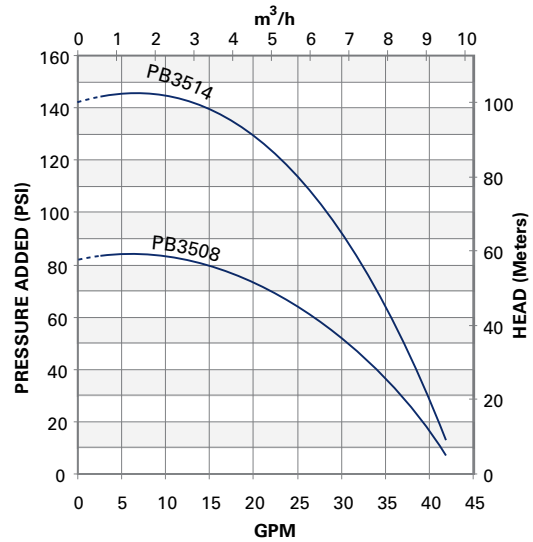

IL0510

Do not operate pumps in flow range indicated by dotted line.

FOUNTAIN SYSTEMS FOR BEAUTIFUL WATERSCAPES

FW1145
0920
Supersedes
0417

APPLICATIONS

- Private residential ponds
- Apartment complexes
- Industrial centers
- Golf courses
- Waterscapes
- City parks

THREE EASY CHANGE PATTERNS INCLUDED

- Easily interchangeable nozzles to achieve three different spray patterns
- Polyethylene, foam-filled flotation system: UV resistant, will not waterlog
- Stainless steel eye bolts anchor system to pond bottom or shore line with nylon rope
- Six inch diameter, slotted PVC screen provides large surface area to filter debris and draw water from below the pond surface area
- Four inch diameter pump fitted with stainless steel and thermal plastic components
- Water-cooled motor with stainless steel shell. Oil-free design.
- 100 ft. S00W waterproof cord with ground fault interruptor on 115V models. 100 ft. heavy duty 14 Ga. waterproof cord with heat shrink splice on 230V models. Optional cable available in 50 ft. increments up to 150 ft. additional. Maximum cable length 250 ft.
- 230V models include rain-proof, lockable control center. Includes internally mounted ground fault interrupter and 24 hour adjustable timers for pump and optional lights.

115V Model:
FPS0501

230V Models:
FPS05021, FPS07021,
FPS10021
230V model shown



FPS0501, FPS05021, FPS07021,
FPS10021



1/2 HP 115V or 230V; 3/4 and 1 HP 230V

Single phase

Operates in 5 ft. of water or deeper

SYSTEM SPECIFICATIONS

MODEL NO.	HP	PHASE	VOLTS	RUNNING AMPS	SYSTEM CABLE LENGTH	MAX. CABLE LENGTH
FPS0501	1/2	1	115V	12	100 FT.	100 FT.
FPS05021	1/2	1	230V	6	100 FT. ‡	250 FT. †
FPS07021	3/4	1	230V	8	100 FT. ‡	250 FT. †
FPS10021	1	1	230V	9.8	100 FT. ‡	250 FT. †

‡ Optional cable available in 50 ft. increments up to 150 ft additional.

† Maximum cable length from fountain to control. For wire specifications and size from the control panel to the fuse disconnect box, consult a licensed electrician. A licensed electrician should perform electrical installation in accordance with national and local electrical codes.

FOUNTAIN NOZZLE SPECIFICATIONS

MODEL NO.	HP	WATER LILY			SKY CANNON		WATER TRUMPET		
		"A"	"B"	Flow	"A"	Flow	"A"	"B"	Flow
		HT.	DIA.	GPH*	HT.	GPH*	HT.	DIA.	GPH*
FPS0501 / FPS05021	1/2	15	30	4900	15	3300	13	15	2700
FPS07021	3/4	22	32	5825	35	4100	20	25	3400
FPS10021	1	24	46	6150	41	4200	22	35	3600

*Water displacement gallons per hour.

THREE EASILY INTERCHANGEABLE PATTERNS INCLUDED

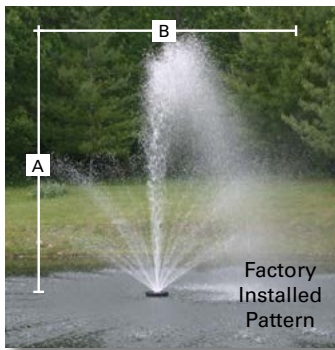

Water Lily
An eye-catching combination spray

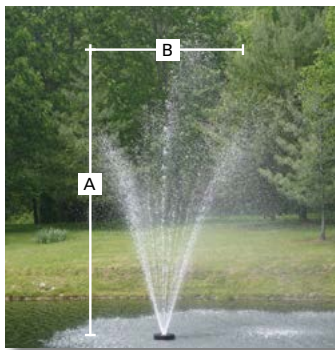

Water Trumpet
A symmetrical inverted bell shape

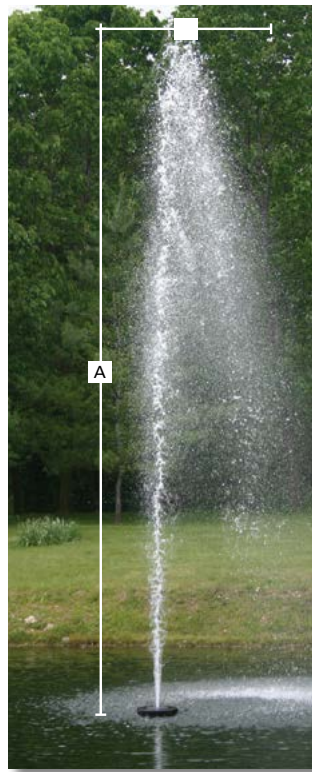

Sky Cannon
A dramatic single plume of water



Water Lily



Water Trumpet



Sky Cannon



LIGHT UP THE NIGHT WITH THE OPTIONAL "NightBright" SYSTEM



Now available for all models

ADDITIONAL PUMP CABLE PACKAGES FOR 230V "FPS" FOUNTAIN SYSTEMS			
CABLE	CABLE LENGTH FT.		
	50'	100'	150'
PART NO.			
14 GA. SOOW	022923	022924	022925
12 GA. SOOW	022920	022921	022922

Cable packages include 022919 heat shrink splice kit

OPTIONAL QUICK DISCONNECT	HEAT SHRINK SPLICE KITS
<p>The optional Quick disconnect for the motor electrical connection enables disconnecting the unit for cleaning and winter storage. Part No. 022918</p> 	<p>For use on 14 and 12 gauge pump cable. Part No. 022919</p>  <p>For use on 18 GA. light cable. Part No. 022933</p> 

OPTIONAL FOUNTAIN "NIGHT BRIGHT" LIGHTING SYSTEM

Flint & Walling floating fountains are even more dramatic at night with the addition of a "Night Bright" lighting system. The three light, 120V, 120 watt equivalent system includes stainless steel housings that can easily be installed onto the float. The fountain control center includes an adjustable 24 hour timer for controlling the "Night Bright" lighting system.

OPTIONAL 120V LIGHT KITS	
PART NO.	STANDARD LIGHT KIT PACKAGE COMPONENTS
023069	<ul style="list-style-type: none"> • Three white LED lamps † • 100 Ft. of 18 GA. AWG SOOW underwater cable ‡ • Stainless steel mounting brackets and hardware • Heat shrink splice kit
023369	Light kit with GFI connector for fountain systems without control box



† Optional colored lamps are available in red, green and blue sets of 3.
‡ Optional cable available in 50 ft. increments up to 150 ft additional.

ADDITIONAL LIGHT CABLE PACKAGES FOR OPTIONAL LIGHTING SYSTEM			
CABLE	CABLE LENGTH FT.		
	50'	100'	150'
PART NO.			
18 GA. SOOW	022930	022931	022932

Cable packages include 022933 heat shrink splice kit

COLORED LED LAMP SETS FOR OPTIONAL "NIGHT BRIGHT" LIGHTING SYSTEM

Part No.	Description			
023059	Red	  		
023058	Green			
023057	Blue			

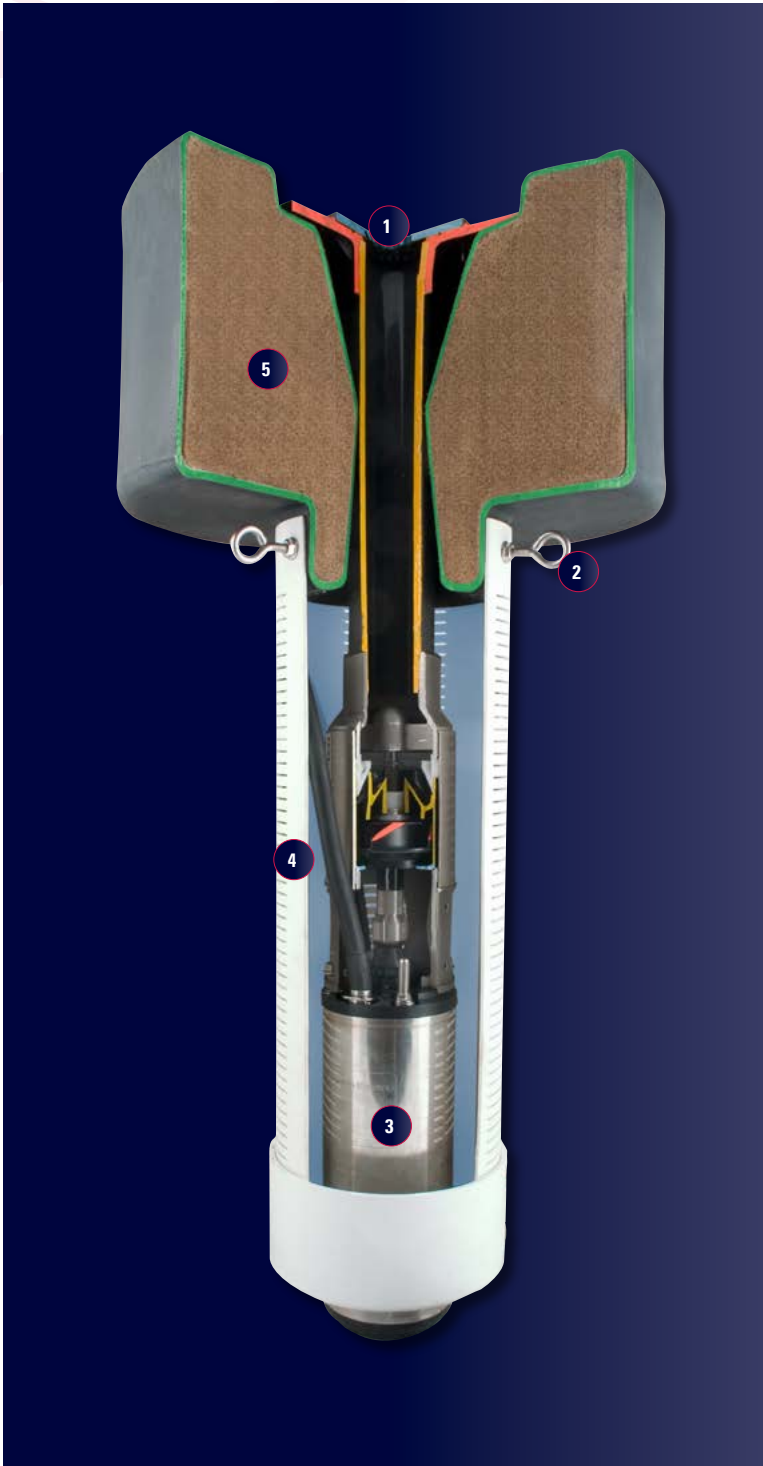

1. Interchangeable nozzle
2. Stainless steel eye bolts anchor system to pond bottom or shore with nylon rope
3. Four inch diameter pump and motor fitted with stainless steel and thermal plastic components for maximum corrosion resistance
4. Six inch diameter, slotted PVC screen provides large surface area to filter debris and draw water from below the pond surface area
5. Polyethylene, foam filled flotation system; UV resistant, will not waterlog

WARNING: Not tested or approved for use in swimming areas

City Water Booster Pump



CITY WATER BOOSTER PUMP

FW1492
1020
Supersedes
0917



More pressure where you want it . . . when you need it!

- All-in-one unit, consisting of pump, motor, stainless steel pressure tank and electronic controller
- Compact design and quiet operation make it suitable for many applications
- System has automatic built-in diagnostics to protect against:
 - Run Dry
 - Dead Head
 - Rapid Cycling
- Impeller constructed of stainless steel with stainless steel bearing and shaft sleeve
- 1 in. stainless steel inlet and outlet flanges



Model VP05
1/2 HP

Model VP10
1 HP

1/2 and 1 HP , 115V

Pressures to 112 PSI

Flow rates to 27 GPM



PERFORMANCE

DO NOT EXCEED 30 PSI incoming pressure

Inlet PSI	VP05 System Pressure (PSI) at Flow Rates (GPM)							HP
	3	6	9	12	15	18	21	
10	43	36	35	31	26	-	-	1/2
20	53	46	45	41	36	-	-	
30	63	56	55	51	46	-	-	

DO NOT EXCEED 50 PSI INCOMING PRESSURE

Inlet PSI	VP10 System Pressure (PSI) at Flow Rates (GPM)							HP
	3	6	9	12	15	18	21	
10	72	67	61	56	50	45	39	1
20	82	77	71	66	60	55	49	
30	92	87	81	76	70	65	59	
40	102	97	91	86	80	75	69	
50	112	107	101	96	90	85	79	

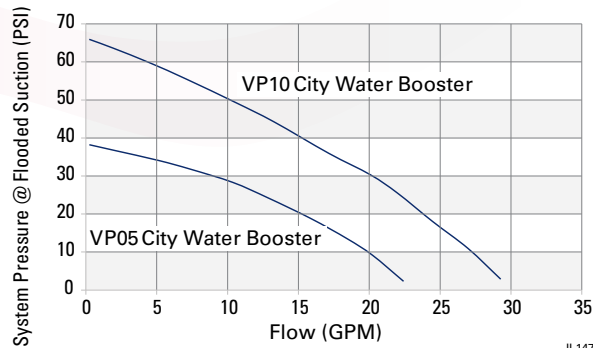

Outline / Dimensional Size

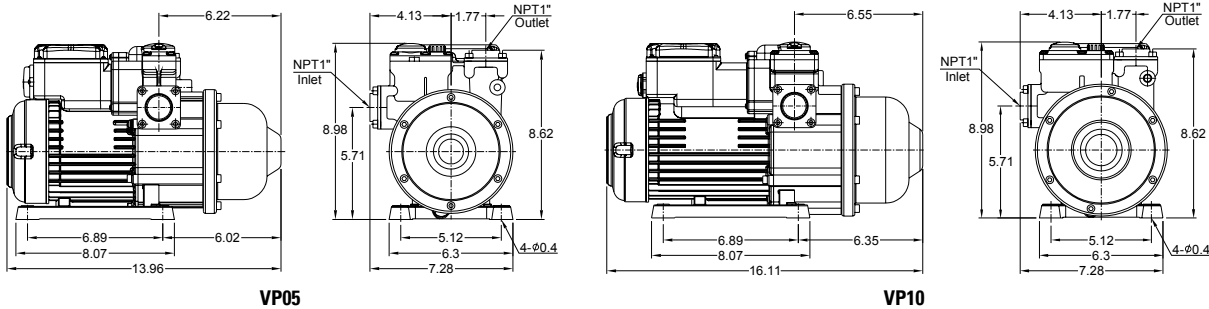

TYPICAL INSTALLATION

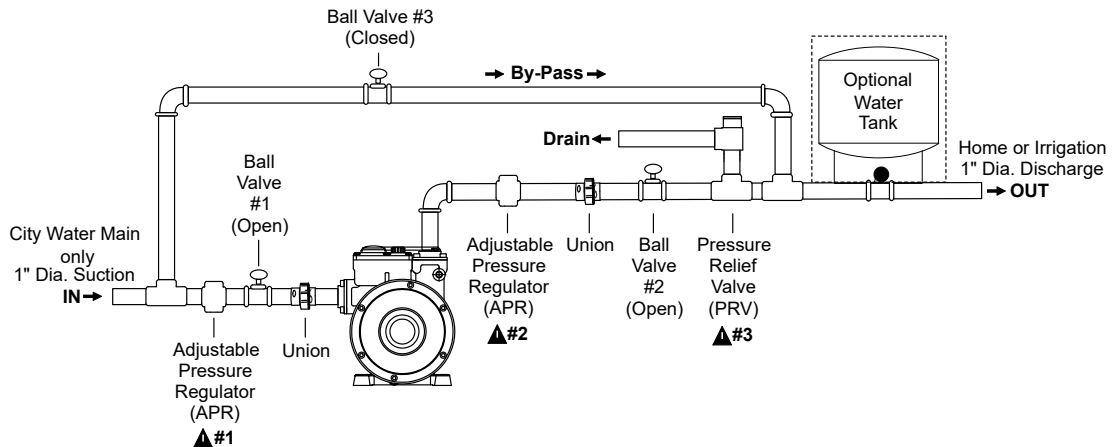

POULTRY MARKET CATALOG

FW0134
1020
Supersedes
0120



- Evaporative Cooling Pumps:
1-1/2 or 2 in. discharge
- Centrifugal Booster Pumps
- Pressure Booster Pumps
- Engineered Poultry Pumping Systems
- One year limited warranty



Capacities to 145 GPM

Pressures to 200 PSI

For Poultry Evaporative Cooling Applications - 2" Discharge



- Rugged oil filled motor
- Thermal overload protects against overheating
- Powder-coated, cast iron design dissipates motor heat to ensure long life
- 2" discharge for 2" solids pumping capacity
- 2" Bottom suction inlet with vortex impeller
- 9 ft. waterproof power cord with grounded plug
- Silicon carbide / carbon seal (designed for continuous runs), for long life
- Temperature rating: 104°F (40°C)
- One year limited warranty

 US
 Tested to UL Standard
 UL778
 and Certified to CSA
 Standard CSA22.2
 No. 108



PERFORMANCE

Model	HP	Amps	Hz	Gallons Per Minute Lift Capacity			
				5 Ft.	10 Ft.	15 Ft.	20 Ft.
50TCPPC	1/2	9.5	60	95	80	45	20
ECP552PC	1/2	4.0	60	95	80	45	20
ECP752PC	3/4	4.0	60	103	89	63	37

ECPPC / 50TCPPC Evaporative Cooling Pumps

PERFORMANCE

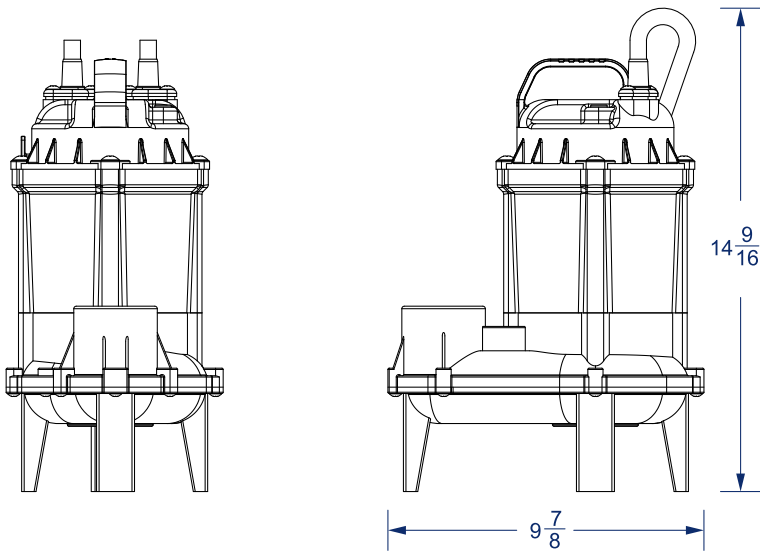
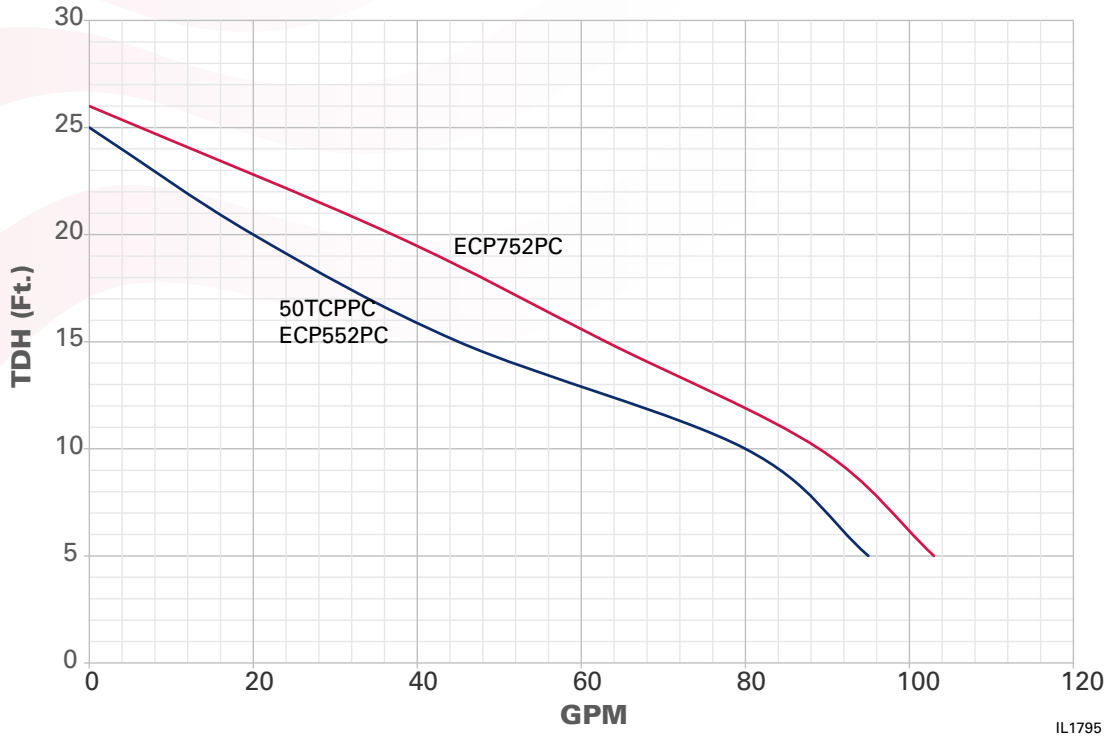

IL1083

50TCPPC, ECP552PC, ECP752PC

Total Ht. (in.)	Total Width (in.)	Wt. (Lbs.)
15.875	9.5	21.0
15.875	9.5	21.0
15.875	9.5	21.0

For Poultry Evaporative Cooling Applications - 1-1/2" Discharge



- Durable, powder-coated epoxy cast iron construction
- Stainless steel lifting handle and bolts
- Non-clogging thermoplastic vortex impeller design
- ECP3 series passes 1/2" spherical solids. ECP4 and ECP5 series pass 3/4" spherical solids.
- Oil-filled, hermetically sealed, automatic reset thermal overload protected motor
- Silicon carbide / carbon seal (designed for continuous runs), for long life
- Upper sleeve bearing and lower ball bearing running in bath of oil
- 20 ft. UL listed power cord with molded 3-wire plug
- 1-1/2" NPT vertical discharge
- Operates at temperatures to 130° F (54 C°)
- Glass-filled polypropylene base



US
Tested to UL Standard
UL778
and Certified to CSA
Standard CSA22.2
No. 108



PERFORMANCE

Model No.	HP	Volt	Amps	Hz	Gallons Per Minute Lift Capacity			Shut Off Ft.	
					5 Ft.	10 Ft.	15 Ft.		
ECP301	.30	115	9.7	60	47	37	25	20.5	
ECP302		230	4.8						
ECP331	.33	115	6.0		55	50	43		32
ECP332		230	3.2						
ECP401	.40	115	8.5		69	64	55		39
ECP402		230	4.3						
ECP501	.50	115	10.5		77	70	61		44
ECP502		230	5.3						

ECP Series Pumps for Poultry Applications



ECP Evaporative Cooling Pumps

Evaporative Pumps

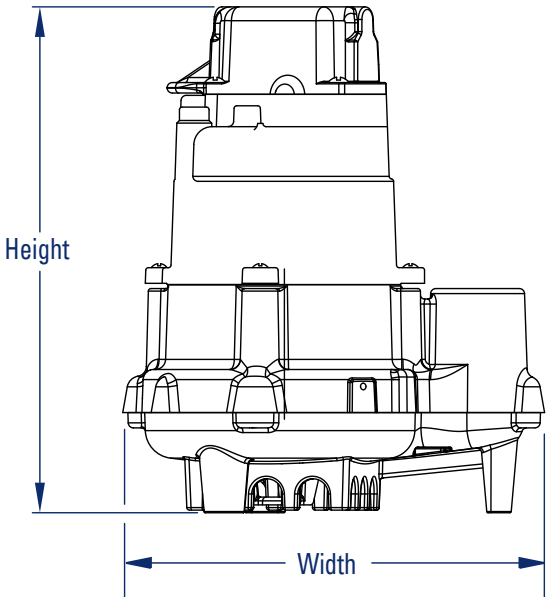
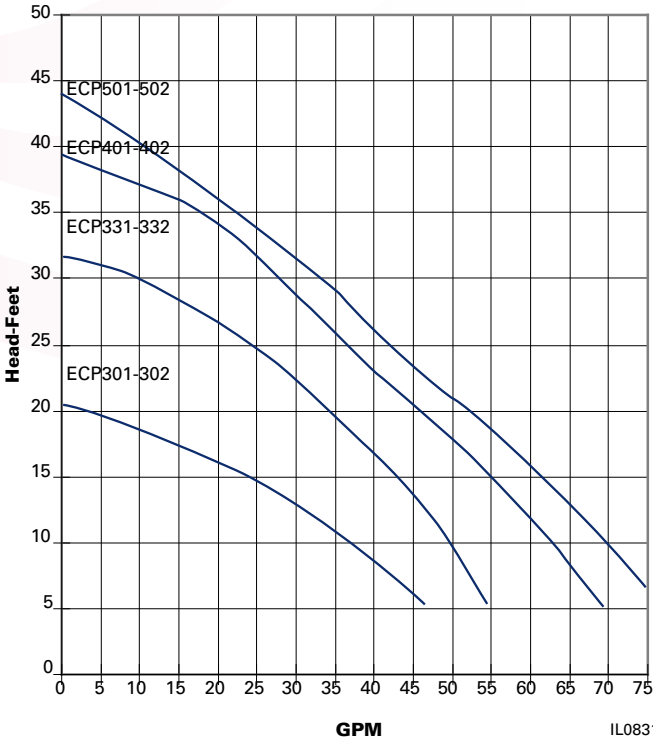

ECP301, 302, 331, 332, 401, 402, 501, 502

Total Height	Total Width	Weight Lbs.	Discharge NPT
10.063"	10.006"	22.4	1-1/2"
11.688"	10.094"	32.0	
12.125"		37.0	
		39.0	

SUMP PUMPS, EFFLUENT PUMPS AND SEWAGE PUMPS

FW0109
1020
Supersedes
0319

FOR WATER, EFFLUENT AND SEWAGE REMOVAL

- Non-clogging vortex impeller on submersible models
- Premium vertical switch
- Thermal overload protected
- Cast iron or thermoplastic models available
- 100% factory tested for reliable operation



3SEL, F1098, F1137, 40ECF



.3 - 1/2 HP

Up to 90 GPM

Lifts to 25 ft.



Cast Iron Contractor Sump/Effluent Pumps



- Non-clogging vortex impeller passes 1/2" solids
- Corrosion-resistant, powder coated epoxy finish
- .3 HP, 115V, 9.7 amps
- Cast iron switch case, motor and pump housing for long life and quiet operation
- Solid, buoyant float material and stainless steel float switch arm ensure long term reliability
- 1-1/2" NPT discharge to meet commercial code requirements
- Thermal overload protection keeps motor from overheating
- 2-pole, float operated switch
- Maximum temperature for effluent or dewatering - 130°F (54°C)
- 1-year limited warranty.



Model	HP	Discharge Pipe Size	Gallons Per Minute Lift Capacity		
			5 ft.	10 ft.	15 ft.
3SEL	.3	1-1/2" *	43	34	19

*Reduces to 1-1/4" with P/N 024784

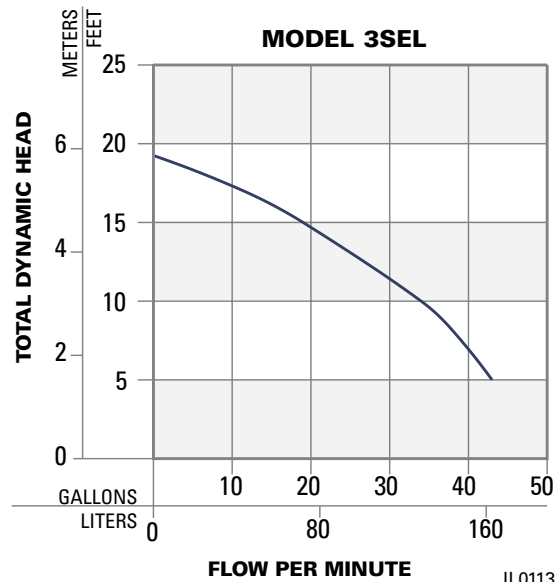

Cast Iron Contractor Sump/Effluent Pumps



5SE

- Premium vertical switch easily fits into pits as small as 10 inches in diameter
- Rugged cast iron motor housing for long life
- Highly efficient, overload protected, oil-filled motor
- Non-clogging vortex impeller effectively removes lint and debris
- All stainless steel hardware
- 1-1/2" NPT discharge - passes 3/8" solids
- 100% tested before shipment for reliable operation
- 1-year limited warranty



Model	HP	Discharge Pipe Size	Gallons Per Minute Lift Capacity		
			5 ft.	10 ft.	15 ft.
5SE	1/2	1-1/2"	50	40	30

*Reduces to 1-1/4" with P/N 024784

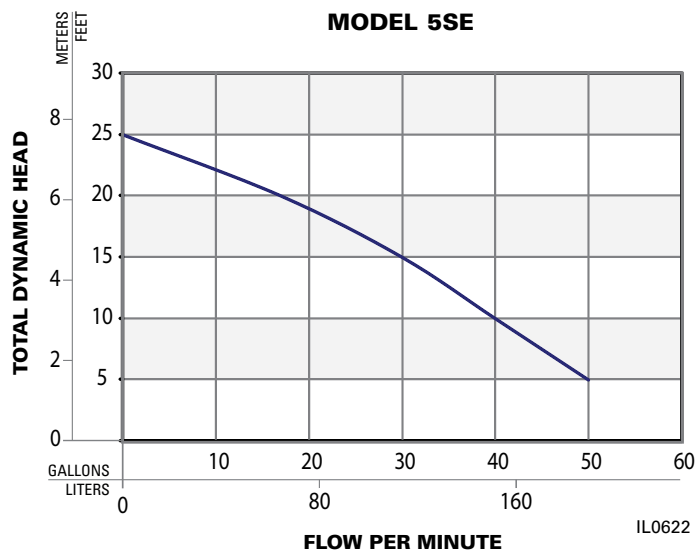

HIGH CAPACITY CONTRACTOR SUMP/EFFLUENT PUMP



- 1/2 HP, 115V, 9.4 amps
- Epoxy coated cast iron construction for long life
- Stainless steel components will not rust or corrode
- Thermal overload protection keeps motor from overheating
- Oil-filled, hermetically sealed high efficiency motor for dependable service
- 1-1/2" NPT discharge - passes 1/2" spherical solids
- 100% water tested before shipment for reliable operation
- Temperature rating: 130°F (54°C)
- 1-year limited warranty



F1098



Model	HP	Discharge Pipe Size	Gallons Per Minute Lift Capacity			
			5 ft.	10 ft.	15 ft.	20 ft.
F1098	1/2	1-1/2"	72	61	45	21

*Reduces to 1-1/4" with P/N 024784

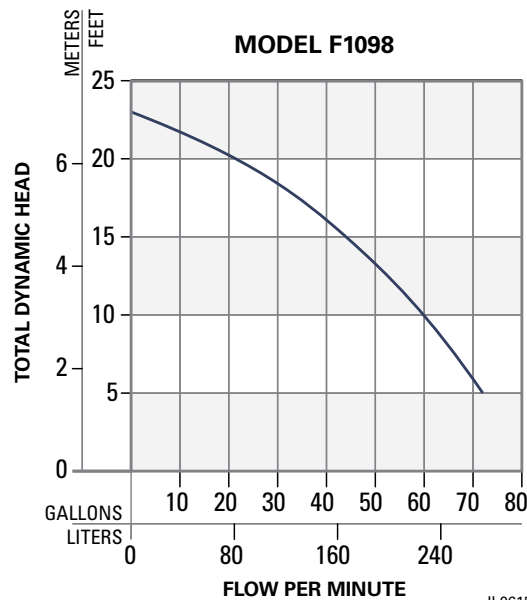

IL0615

Submersible Sump / Dewatering Pump



High Head Contractor Sump/Dewatering Pump



- 1/2 HP, 115V, 10.7 amps
- Epoxy coated cast iron construction for long life
- Stainless steel components will not rust or corrode
- Thermal overload protection keeps motor from overheating
- Oil-filled, hermetically sealed high efficiency motor for dependable service
- Waterproof cord with grounded plug for easy replacement of pedestal pump in a wet environment
- 1-1/2" NPT discharge - passes 5/8" solids
- 100% water tested before shipment for reliable operation
- Temperature rating: 130°F (54°C)
- 1-year limited warranty



F1137

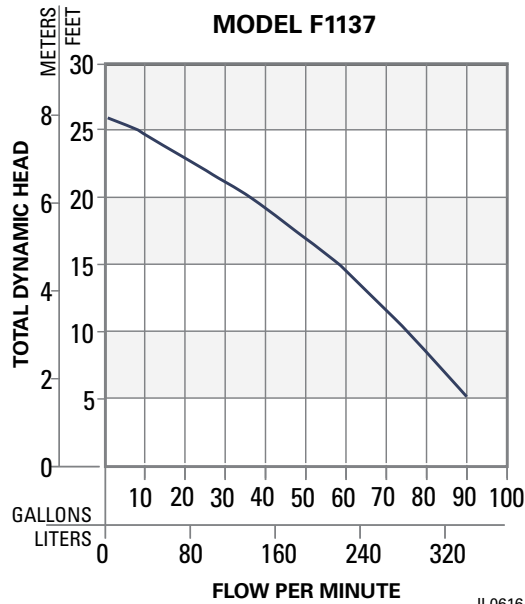

Cast Iron and Thermoplastic Column Sump Pumps



3CE



3CD



- Open type non-clogging multi-vane impeller
- Heavy duty motor - 115V, 60 cycle, single phase, 1725 RPM
- 3CE 1/3 HP, 4.0 Amps; 3CD 1/3 HP, 5.7 Amps
- Thermal overload protection keeps motor from overheating
- Waterproof cord with grounded plug
- Easily adjustable on/off float and rod type switch
- Top suction strainer filters out debris
- Durable shaft securely fits to impeller
- Operates in 130°F water continuously; 150°F intermittently
- Conveniently fits into 12" diameter pit
- 1-year limited warranty

Model	HP	Base	Discharge Pipe Size	Gallons Per Minute Lift Capacity		
				5 ft.	10 ft.	15 ft.
3CE	1/3	Thermoplastic	1-1/4"	50	36	10
3CD	1/3	Cast Iron	1-1/2" *	50	41	22

*Reduces to 1-1/4" with P/N 024784

MODEL 3CE

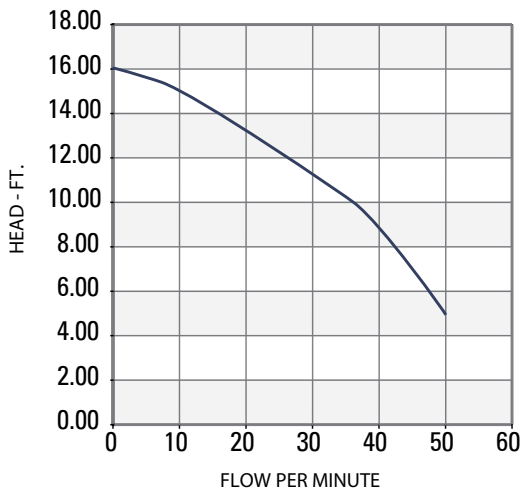

IL0617

MODEL 3CD

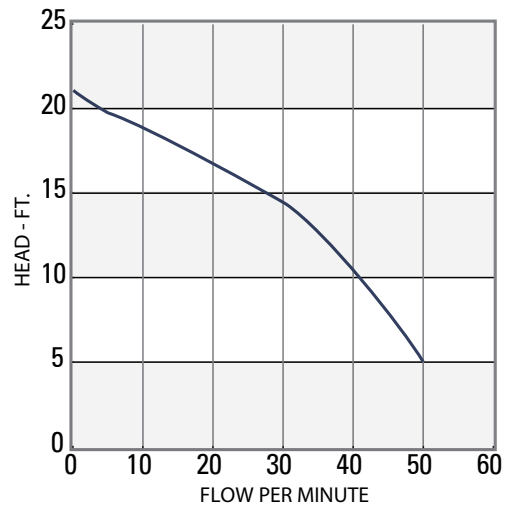

IL0618

.4 HP Submersible Sewage Ejector Pump



4EPF

- Bottom suction inlet with vortex impeller
- 2" NPT discharge with 2" solids pumping capacity
- Double seal for reliable service and extended life
- Premium vertical float switch
- High efficiency, .4 HP, 115V, 60 Hz motor 5.5 amps
- Environmentally friendly oil-free motor runs cooler and lasts longer
- Thermal overload protects against overheating
- Waterproof power cord with grounded plug
- Temperature Rating: 110°F (43°C)
- 1-year limited warranty



Model	HP	Gallons Per Minute Lift Capacity		
		5 ft.	10 ft.	15 ft.
4EPF	.4	82	53	32

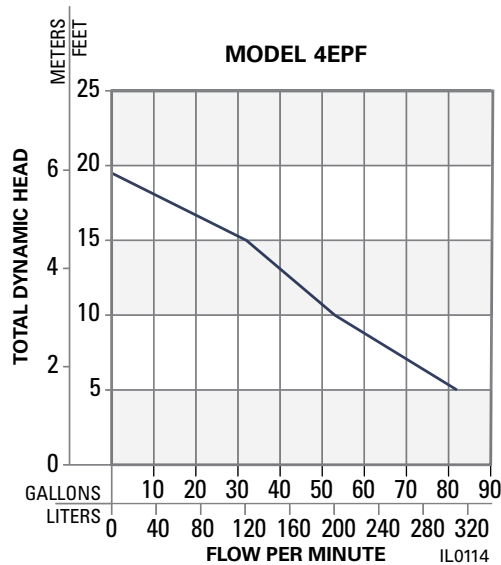

Cast Iron Submersible Sewage Ejector Pump



- Rugged oil filled .4 HP, 115V, 60 Hz. motor 9.4 amps
- Thermal overload protects against overheating
- Epoxy coated, cast iron design dissipates motor heat for long life
- 2" discharge with 2" solids pumping capacity
- Bottom suction inlet with vortex impeller
- 10' waterproof power cord with grounded plug
- Ceramic and carbon seal for reliable service and extended life
- Temperature Rating: 130°F. (54°C.)
- 1-year limited warranty



40ECF

Model	HP	Gallons Per Minute Lift Capacity		
		5 ft.	10 ft.	15 ft.
40ECF	.4	90	60	23

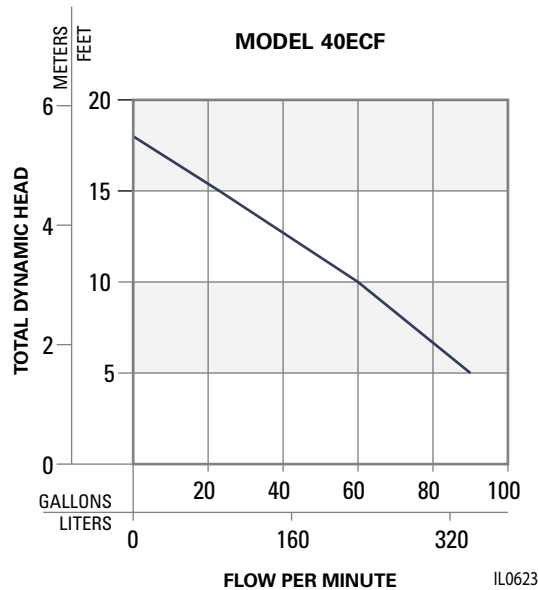

Multi-Stage Effluent 4 Inch Submersible Pumps



Multi-Stage Effluent 4 Inch Submersible Pumps

FW0714
0221
Supersedes
0920

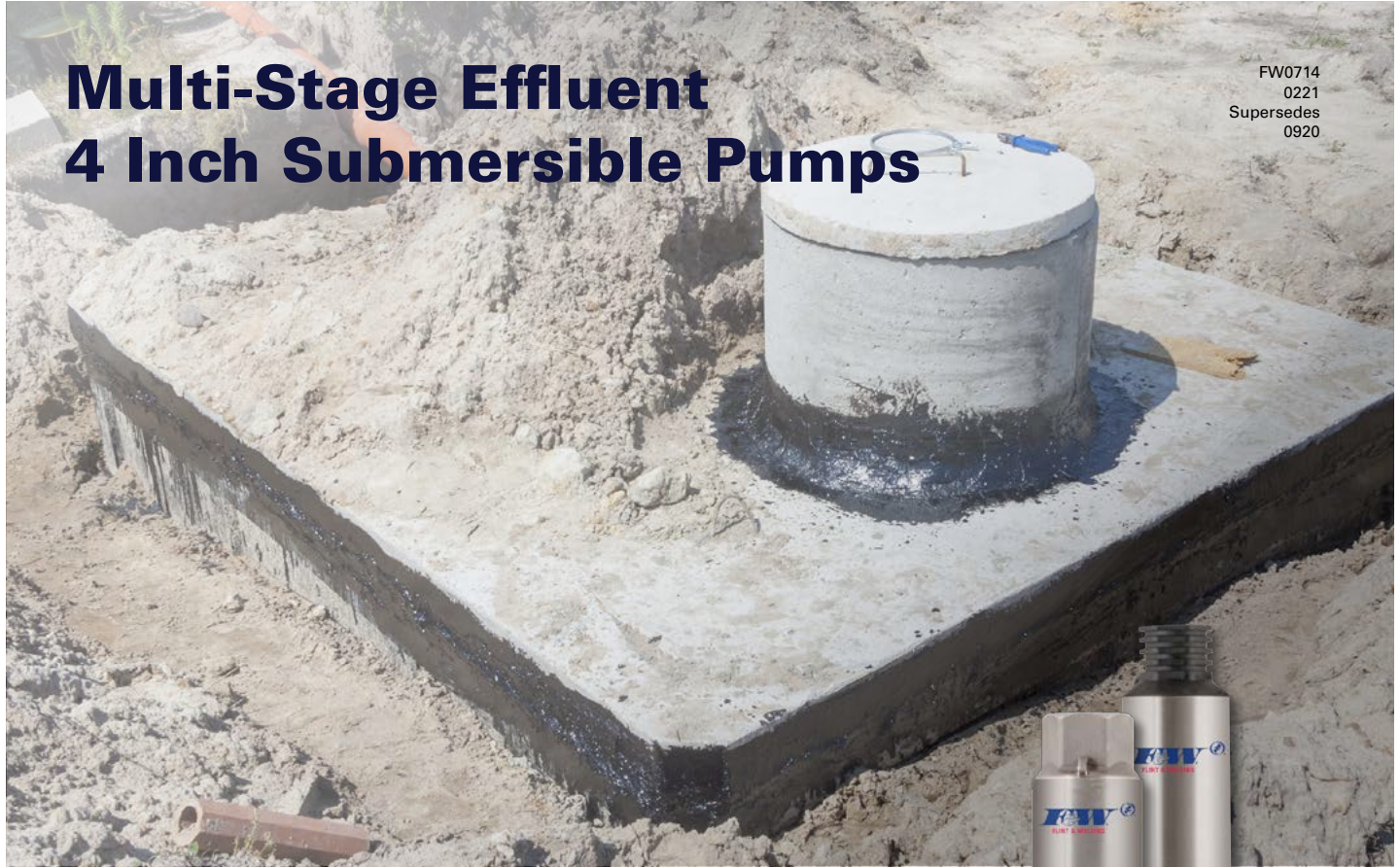

Multi-stage effluent submersible pumps are used in on-site applications that demand more head than a traditional single stage centrifugal pump. This need is met by offering a complete line of submersible effluent turbine pumps. These pumps have been proven in field applications and have many years of development behind them.

Typical applications include mound systems, drip systems, and recirculation media filters. All units include cool running submersible motors that do not require external water flow to prevent overheating. Therefore, an outer pump sleeve is not required for models less than 2 HP. Pumps can be installed directly in a dose tank as long as an effluent filter is used on the septic tank outlet. These pumps can also be used in conjunction with a filtered STEP system.



Features

- Corrosion resistant
- Models available: 11, 19, 27 35 and 55 GPM.
- 1/2 thru 1 HP units
- 115 and 230 volts
- 1-1/4" discharge (11, 19, 27 gpm) or 2" discharge (35 and 55 GPM)
- Heavy wall stainless steel pump shell
- NEMA standard submersible motors
- Stainless steel hex drive pump shaft
- High efficiency floating stack
- Glass-filled Noryl® discharge and mounting ring (1/2 thru 1 HP; 11, 19, and 27 gpm models)
- Stainless steel discharge and mounting ring (35 and 55 GPM models)
- No external capacitors or relays required for starting.
- Check valve not included
- Replaceable motor lead assembly

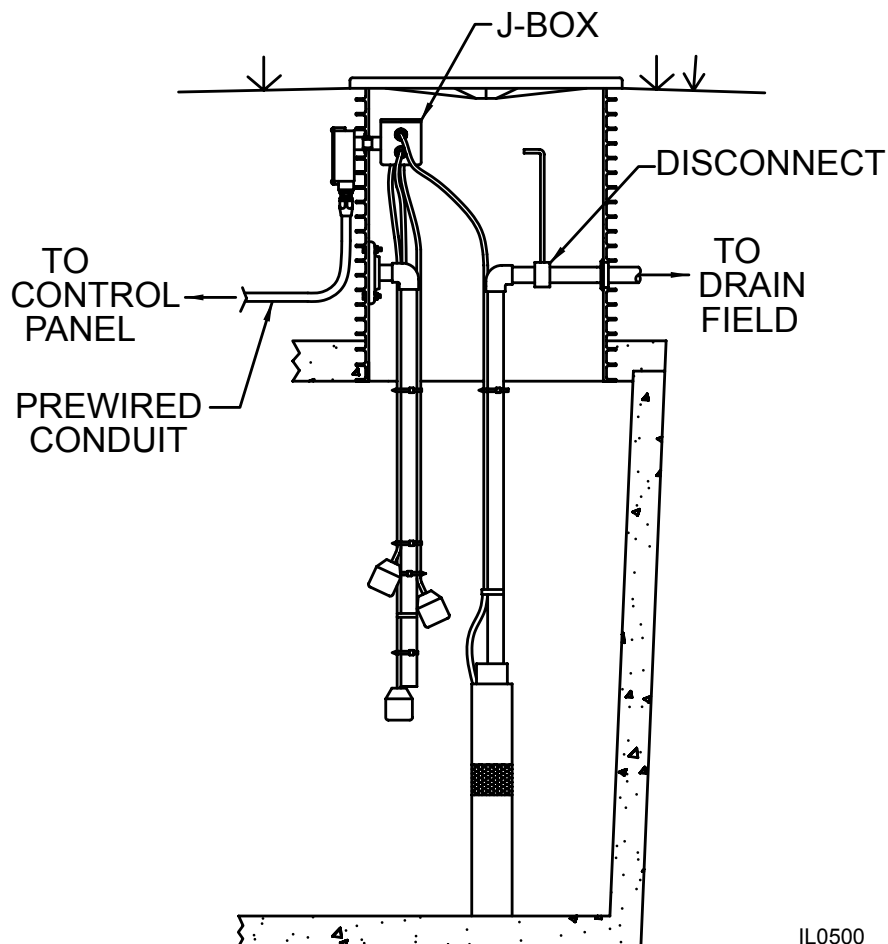

IL0500

Multi-Stage Effluent 4 Inch Submersible Pumps



11 GPM MODELS

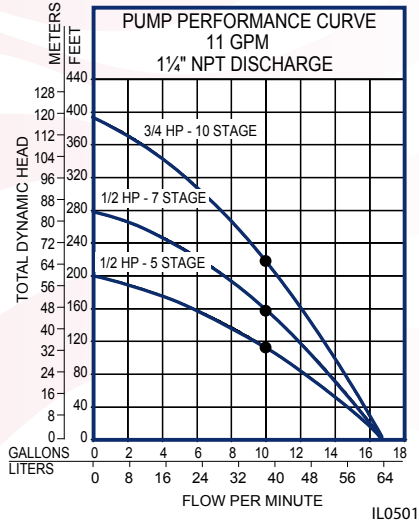

Part Number	HP	Voltage	Phase	Amps	Stages	Height
F5030-0005‡	1/2	115	1	12.0	5	23"
F5030-0006‡	1/2	230	1	6.0	5	23"
F5030-0007‡	1/2	115	1	12.0	7	24-7/8"
F5030-0008‡	1/2	230	1	6.0	7	24-7/8"
F5030-0009‡	3/4	230	1	8.0	10	28-5/8"
F5030-0013 ³	1/2	115	1	12.0	5	23"

‡ Includes 10 ft. of #16-2G S00W-A power cord
³ Includes check valve and weep hole

IL0501

19 GPM MODELS

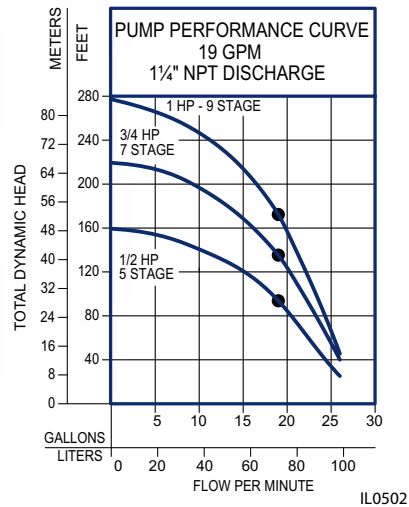

Part Number	HP	Voltage	Phase	Amps	Stages	Height
F5031-0005‡	1/2	115	1	12.0	5	23-1/2"
F5031-0006‡	1/2	230	1	6.0	5	23-1/2"
F5031-0007‡	3/4	230	1	8.0	7	26-5/8"
F5031-0008 ¹	1	230	1	10.4	9	29-1/2"

‡ Includes 10 ft. of #16-2G S00W-A power cord
¹ Includes 10 ft. of #14-2G SJ0W-A power cord

IL0502

27 GPM MODELS

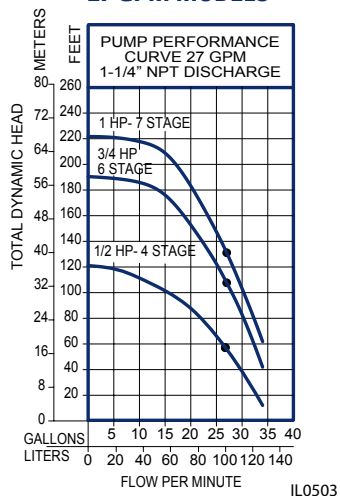

Part Number	HP	Voltage	Phase	Amps	Stages	Height
F5032-0005‡	1/2	115	1	12.0	4	22-3/4"
F5032-0006‡	1/2	230	1	6.0	4	22-3/4"
F5032-0007‡	3/4	230	1	8.0	6	25-7/8"
F5032-0008 ¹	1	230	1	10.4	7	27-3/4"

‡ Includes 10 ft. of #16-2G S00W-A power cord
¹ Includes 10 ft. of #14-2G SJ0W-A power cord

IL0503

35 GPM MODELS

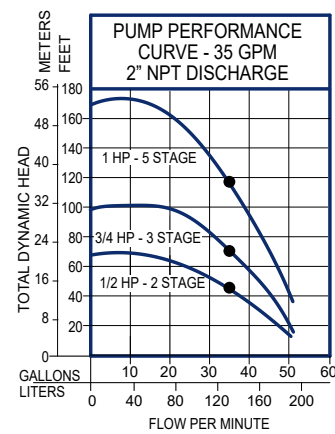

Part Number	HP	Voltage	Phase	Amps	Stages	Height
F5033-0005‡	1/2	115	1	12.0	2	21-1/2"
F5033-0006‡	1/2	230	1	6.0	2	21-1/2"
F5033-0007‡	3/4	230	1	8.0	3	24-1/4"
F5033-0011 ²	1	230	1	10.4	5	31-7/8"

‡ Includes 10 ft. of #16-2G S00W-A power cord
² Includes 50 ft. of #14-2G SJ0W-A power cord

IL0504



FW0019
1120
Supersedes
0618

AIR-E-TAINER® WELL SYSTEM TANKS

Vertical, Horizontal and Inline Well System Tanks

- Inline tanks pre-charged for 30-50 pressure switch - Vertical tanks pre-charged for either 30 – 50 or 40 – 60 Pressure switch
- 100 PSI maximum working pressure
- Powder-coated exterior and interior
- Butyl rubber parabolic diaphragm
- 5 year Limited Warranty



Inline Tanks

Vertical Tanks

Horizontal Tank

AIR-E-TAINER® PRE-PRESSURIZED WELL SYSTEM TANKS

Part No.	Total Tank Vol. Gallons	Drawdown - Gallons by PSI Settings***			Approx. Size In. Dia x Ht	Ship Wt Lbs	NPT Size/ MTL	Factory Precharge PSIG	Max Working Pressure (PSI)	Max Working Temp
		20/40	30/50	40/60						
131009	2	0.7	0.6		8-1/4 x 10-1/5	5	3/4" M	28	100	140
132477	4.6	1.6	1.4		11 x 14-3/4	9	3/4" M	28	100	140
132661	14	5.2	4.3	3.7	15-3/8 x 24-3/4	25.5	1" F	38	100	200
136878A*	14	5.2	4.3	3.8	15-1/3 x 16-7/10	28	3/4" M	28	100	200
132662	20	7.4	6.2	5.4	15-3/8 x 32-1/4	30	1" F	38	100	200
132663	36	13.3	11.1	9.7	20 x 38-5/8	45	1" F	38	100	200
133517	52	19.2	16.1	14	23-3/8 x 38-5/8	77	1-1/4" F	38	100	200
136875	65	23.9	20	17.5	23-3/8 x 46-3/5	87	1-1/4" F	38	100	200
135460	86	31.8	26.7	23.2	23-3/8 x 59	105	1-1/4" F	38	100	200
136876	119.5	44	37	32	26 x 61-1/4	165	1-1/4" F	38	100	200

*With pump stand.

***In keeping with current industry standards, drawdown factors are based on Boyle's law. Actual drawdowns will vary depending upon system variables, including the accuracy and operation of the pressure switch and gauge and operating temperature of the system.

Caution: install a pressure relief valve on any installation where the pump pressure can exceed the tank's maximum working pressure.

NOTE: Precharged tanks cannot ship via air freight.

Air-E-Tainer Features

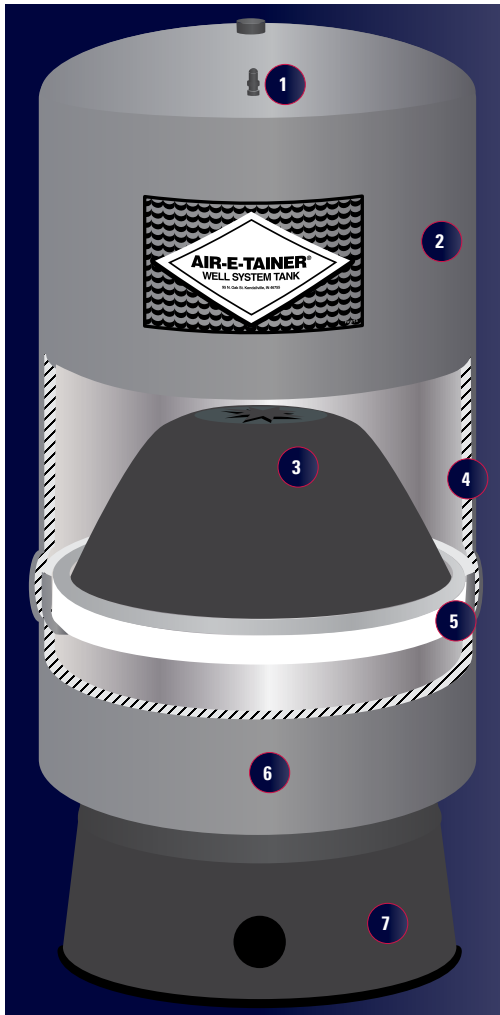

- AIR CHARGE VALVE**
 - Conveniently located for easy pressure adjustment
 - Projection-welded for durability
- DESIGNER FINISH**
 - High gloss exterior powder coat
 - Provides positive protection against corrosion and UV rays
- BUTYL RUBBER PARABOLIC DIAPHRAGM**
 - Eliminates rubbing on the tank wall or rolling over on itself
- STEEL SHELL**
- STEEL RETAINING RING**
- POWDER-COATED WATER CHAMBER**
 - Proven protection against internal corrosion
- CORROSION-RESISTANT BASE**
 - High-impact polymer material
 - Strong and stable for long life
 - Base rotates for easy alignment to pipe connection
 - Slotted and noted for air flow, reduced condensation build-up

Standard 30/50 PSI System

These illustrations show the operation of the Air-E-Tainer® tank in a typical 30/50 pressure range.

A. Tank is pre-pressurized with air at the factory.

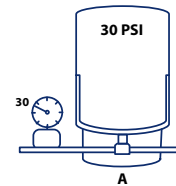

B. When pump starts, water enters the reservoir. At 60 psig, system is filled. Pump shuts off.

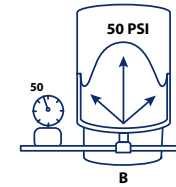

C. When water is demanded, pressure in the air chamber forces water into the system. Pump turns on.

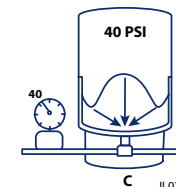

IL0294

STANDARD VERTICAL GALVANIZED WELL SYSTEM TANKS

Order No.	Total Tank Vol. Gals.	Drawdown - Gallons			Approx. Size Inches	Approx. Ship. Wt. Lbs.	Tapping Size - Inches		
		.155 @ 20/40	.101 @ 30/50	.071 @ 40/60			A	B	C
124831	42S	6.5	4.2	3.0	20x34	71	1 1/4	1 1/4	1 1/4
125211	42T	6.5	4.2	3.0	16x51	71	1 1/4	1 1/4	1 1/4
124832	82	12.7	8.3	5.8	20x63	114	1 1/4	1 1/4	1 1/4
124833	120	18.6	12.1	8.5	24x65	154	1 1/4	1 1/2	1 1/2
124834*	220	34.1	22.2	15.6	30x78	303	1 1/4	2	2
124835*	315	48.8	31.8	22.4	36x80	416	1 1/4	2	2

*Non-Stock Item - Consult Factory for Delivery Schedule.

Galvanized Pressure Tanks ... 75 PSI Maximum Working Pressure. 150 PSI Test Pressure.

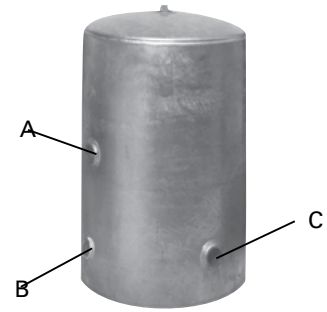

AIR-E-TAINER® PRE-PRESSURIZED WELL SYSTEM TANKS

Part No.	Total Tank Vol. Gallons	Drawdown - Gallons by PSI Settings***			Approx. Size In. Dia x Ht	Ship Wt Lbs	NPT Size/ MTL	Factory Precharge PSIG	Max Working Pressure (PSI)	Max Working Temp
		20/40	30/50	40/60						
131009	2	0.7	0.6		8-1/4 x 10-1/5	5	3/4" M	28	100	140
132477	4.6	1.6	1.4		11 x 14-3/4	9	3/4" M	28	100	140
132661	14	5.2	4.3	3.7	15-3/8 x 24-3/4	25.5	1" F	38	100	200
136878A	14	5.2	4.3	3.8	15-1/3 x 16-7/10	28	3/4" M	28	100	200
132662	20	7.4	6.2	5.4	15-3/8 x 32-1/4	30	1" F	38	100	200
132663	36	13.3	11.1	9.7	20 x 38-5/8	45	1" F	38	100	200
133517	52	19.2	16.1	14	23-3/8 x 38-5/8	77	1-1/4" F	38	100	200
136875	65	23.9	20	17.5	23-3/8 x 46-3/5	87	1-1/4" F	38	100	200
135460	86	31.8	26.7	23.2	23-3/8 x 59	105	1-1/4" F	38	100	200
136876	119.5	44	37	32	26 x 61-1/4	165	1-1/4" F	38	100	200

***In keeping with current industry standards, drawdown factors are based on Boyle's law. Actual drawdowns will vary depending upon system variables, including the accuracy and operation of the pressure switch and gauge and operating temperature of the system.

Caution: install a pressure relief valve on any installation where the pump pressure can exceed the tank's maximum working pressure.

NOTE: Precharged tanks cannot ship via air freight.



In-line tanks
131009
132477



Vertical Tanks
132661 136875
132662 135460
132663 136876
133517

AIR-E-TAINER® PUMP STAND

Order No.	Application
134151	For Mounting Jet Pumps On Top Of 132661, 132662, 132663, 133517, 136875, 135460 and 136876 Air-E-Tainer Tanks



FITTING PKGS. FOR JET PUMP/PRESSURE TANK MOUNTED SYSTEMS

Fittings Pkg Order No.	For Use With		Package Contents
	Pumps	Well System Tanks	
135918	1/3 & 1/2 HP Shallow Well and Convertible Horizontal Jet Pumps	132661 Vertical Air-E-Tainer 132662 Vertical Air-E-Tainer	Nipples, Elbows, Discharge Tee, Hose, Clamps and Pump Stand (134151)
134273		131009 Compact Air-E-Tainer 132477 Compact Air-E-Tainer	Nipples, Elbows and Discharge Tee

PRESSURE TANK ACCESSORIES

AIR VOLUME CONTROL - DIAPHRAGM TYPE

Charges standard pressure tanks with air on each operating cycle. Maintains the correct relationship between the volume of air and quantity of water in the tank.

ORDER NO.	NPT	TYPE	MAX. TANK CAPACITY
023917	3/8"	AV100 Non-Repairable	120 Gallon



Non-Repairable

AIR VOLUME CONTROL - FLOAT TYPE

Maintains the correct relationship between the volume of air and quantity of water in the pressure tank.

ORDER NO.	NPT	TYPE
023916	1 1/4"	Deep Well Less Gauge
023926	1 1/4"	Shallow Well Less Gauge

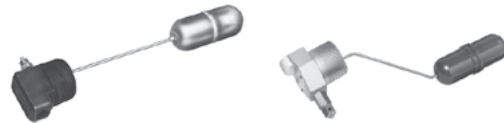

PRESSURE RELIEF VALVE

Order No.	NPT	Release Pressure	Capacity Gallon Per Hour
024777	1/2"	75 PSI	1200 at 70 PSI

NOTE: Install a Pressure Relief Valve with any pump capable of producing more than 75 PSI at the tank.



AIR VALVES

Order No.	NPT	Description
023915	1/4"	Allows admittance of air to any pressure system



JET PUMPS/TANKS SYSTEM FITTINGS

Order No.	Description
134176	1" x 34" Hose



JET PUMP ACCESSORIES

POWER CONVERSION UNIT FOR JET AND CENTRIFUGAL PUMPS

Order No.	Application
122649 NEMA C	Can be used with any jet or centrifugal pump equipped with NEMA C or NEMA J standard electric motors. Gasoline engine or electric motor can be directly coupled with shaft or can be used with belt and pulley. For electric motor used with belt drive, the motor HP should be doubled. The gasoline engine HP should be doubled that of standard motor in either case above.
135458 NEMA J	5/8" Dia. steel shaft, mounted in two heavy duty ball bearings, carry all radial and thrust loads.

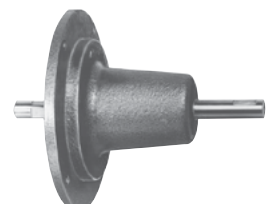

JET PUMP ACCESSORIES

TURNED COUPLING/GALV.

Order No.	Size
129205	1-1/4" NPT



WELL POINT

Order No.	Size	Gauge	Screen Length
120857	1-1/4" x 30"	60	24"
120881	1-1/4" x 36"	60	30"



TOUCH-UP PAINT

Order No.	Description
133367	F&W Blue Spray Can

DRIVE COUPLINGS

Order No.	Description
127486	1-1/4" Coupling for 1-1/4" Drive Pipe

WELL ADAPTERS FOR JET PUMP INSTALLATIONS

Order No.	Description	Well Size	Drop Pipe	Suction Pipe	Pressure Pipe
127025	Right Angle	2"	1"	1-1/4"	1"
129723			1-1/4"	1-1/4"	1"
129719	Straight	2"	1"	1-1/4"	1"
129720			1-1/4"	1-1/4"	1"
022961	Adapter to match Sta-Rite vertical jet pump footprint to F&W "VA," "VS" and "VPH" jet pumps without disturbing existing well plumbing				



Right Angle Adapter



Right Angle Adapter



Straight Adapter

WELL SEALS

Order No.	Description	Well Size	Suction Pipe	Pressure Pipe
120366	Single Pipe Jet Installation	2"	1"	-
126077	Single Pipe Submersible Installation with Cable Seal	4"	1-1/4"	-
129331		4"	2"	-
126369		5"	1-1/4"	-
125760		6"	1-1/4"	-



Single Pipe Submersible

Single Pipe Jet



SUBMERSIBLE ACCESSORIES

SUBMERSIBLE PUMP FITTINGS FOR AIR-E-TAINER AND OTHER CONTAINED AIR TANKS

Brass Tank Cross, Pressure Switch 30/50 PSI, Pressure Gauge, 1/2" Pressure Relief Valve, 1" Check Valve, 1/2" Boiler Drain

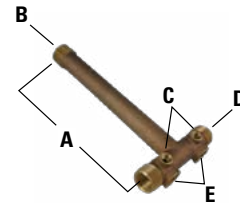

Order No.		Dimensions Inches NPT				
		A	B	C	D	E
023281	Complete Package - Low Lead	10"	1"	1/4"	1" M x 3/4" F	1/2"
024795	Tank Cross Only	10"	1"	1/4"	1" M x 3/4" F	1/2"

SUBMERSIBLE TORQUE ARRESTOR

Eliminates damage to submersibles due to high starting torque.

Order No.	Description
024783	Adjustable to well casings from 4" to 8" I.D.



SUBMERSIBLE CABLE GUARD

Prevents power cable from abrading against side walls of well casing.

Order No.	Description
024770	Fits 6" well-cut tabs for use in 4" and 5" wells



POLYPROPYLENE SUBMERSIBLE SAFETY ROPE

Order No.	Description
134099	500 ft. reels (no cut lengths)



SUBMERSIBLE POWER CABLE WITH GROUND

500 Ft. random reels (no cut lengths)

Wire Size	T-PRENE Jacket†	Plastic Jacket‡	
	3-Wire Order No.	3-Wire Order No.	2-Wire Order No.
No. 12	262-123-53	262-123-54	261-122-54
No. 10	262-103-53	-	-

† TPR Insulation, Copper Conductor

‡ TW Insulation, Standard Copper Conductor



SPLICE KITS

Order No.	Wire Sizes
134100	#14, #12, #10
136755	#8, #6

ELECTRICAL ACCESSORIES

LIGHTNING ARRESTORS

Part No.	Description
127103	Franklin, spark gap 1-Phase 250 Volts (Max.)—1 Req'd.
020165	F&W metal oxide varistor, 1-phase, 240 volt max. - 1 req'd



BW WATER LEVEL CONTROL - Type 1500G

Provides automatic low level cutoff protection for submersible pumps and deep well turbines

Part No.	Description	Qty Req'd
020097	Control, 208-230V, 50/60 Hz, NEMA 1, pump up or pump down	1
125748	Type LH Relay Rated 1 HP, Single Phase, 208-240V, 50/60Hz	
127835	Electrode	2
267-001-40	Suspension Wire-500 Ft. Reels	*

*No cut length.



LEAD WIRES FOR FLINT & WALLING MOTORS

Order No.	Motor Diameter	Description
022797	4"	3 Wire, Plain One End, 48" 14 AWG
022788	4"	2 Wire, Plain One End, 48" 14 AWG

PUMPSAVER PLUS SINGLE PHASE MOTOR PROTECTION

Control Type	HP	Volts	P/N	Wt.
PumpSaver Insider	1/3 - 1	230	023803	1.0
	1/3 - 1-1/2	230	023804	3.5
PumpSaver Plus	1/3 - 3	230	023805	3.5
	5 - 7-1/2	230	023806	4.0



SUBMERSIBLE ACCESSORIES

PRESSURE SWITCHES

Order No.	Switch Setting	Bottom Connection NPT	Maximum Electrical Rating		
			Single Phase		Three Phase
			115V	230V	115V
020345	20-40	1/4M	1 HP	1-1/2 HP	2 HP
020346	30-50	1/4 M	1-1/2 HP	2 HP	3 HP
130723*	20-40	1/4 F	1 HP	1-1/2 HP	2 HP

NOTE: All switches are two pole.
*Indicates low pressure cut off.



OPEN TANK FLOAT SWITCH

Order No.	Description	Max. Switch Ratings	Qty. Req'd
125272	Switch only (heavy duty)	2 HP, 120V, 1 PH 3 HP, 240V, 1 PH 5 HP, 240V, 3 PH	1
125274	Float rod 60" long		1
135266	Stop, rod (rubber)		4

For complete switch, order all parts in quantity as listed above.

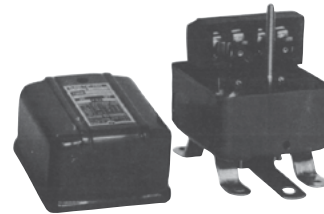

CHECK AND FOOT VALVES

CHECK VALVES

Spring controlled, general service for jet, submersible or centrifugal, for horizontal or vertical application

ORDER NO.	NPT	CAN BE USED IN PIPE SIZE INCHES
024769	1"	2"
023427	1" FPT x 1-1/4" MPT	2"



FOOT VALVES

Spring controlled,
Jet or centrifugal, for vertical application

ORDER NO.	NPT	WELL PIPE SIZE
136294	1"	2"
136295	1-1/4"	2-1/2"
023226	2"	3-1/2"



4" SUBMERSIBLE MOTORS AND CONTROL BOXES

FW1637
0922
Supersedes
0321

Motor Application Guide

Flint & Walling 4" Submersible Motors provide quality in the details:

- Nitrile rubber shaft seal . . . three-part design protects motor from contamination
- Stainless steel shaft . . . features polished bearing journals for extended bearing life
- Copper-wound stator for superior performance
- Stainless steel carbon graphite Kingsbury thrust bearing . . . provides self-aligning axial support up to 700 lbs. for reliable operation
- Stainless steel shell . . . hermetically sealed for maximum corrosion resistance
- Precision-ground radial bearings . . . for high load capability and long life



Motors: 1/2 through 2 HP

2-Wire and 3-Wire Single Phase

Control Boxes: 1/2 through 5 HP



F&W 4" Submersible Motors



STAINLESS STEEL MOTORS

TESTED. TO THE CORE.

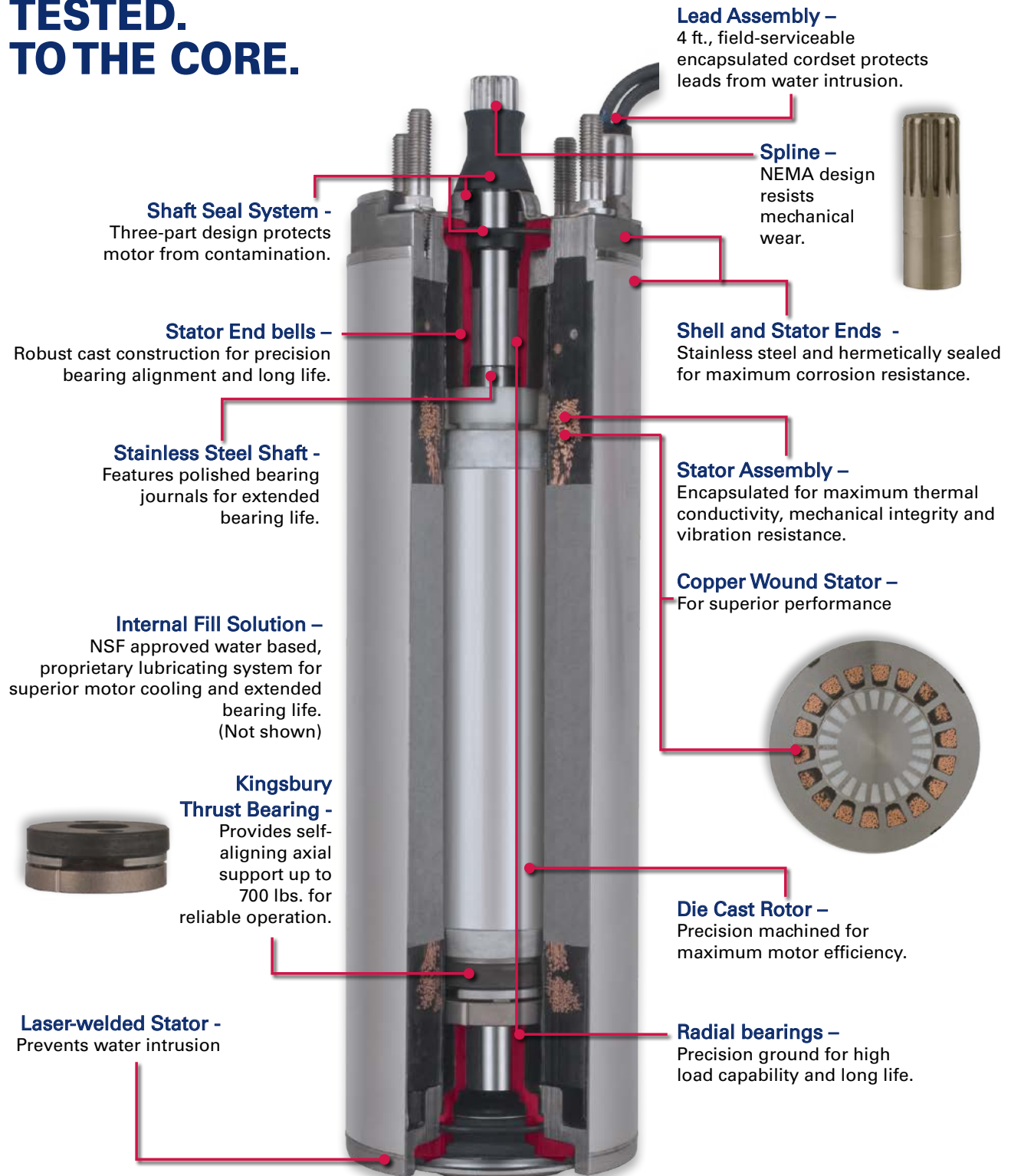

STORAGE AND HANDLING

Long and reliable motor life is supported by Flint & Walling proprietary NSF food safe internal motor fill solution, acting as a lubrication solution for the bearing system and shaft lip seal. The anti-corrosive additives prevent internal corrosion and promote long running life.

Long term storage should be limited to 115° F. During horizontal storage, fill solution may weep through the check valve, creating slight loss of liquid. This is not a concern for the running performance of the motor. Cold storage down to -30° F will not damage the motor due to the anti-freeze protection provided by the fill solution.

INSTALLATION – VERTICAL VS. HORIZONTAL POSITION

The pump is designed to be vertically positioned with the pump end up. The pump applies down thrust onto the motor, which seats the axial bearing firmly into the running position. If the application requires the pump to be placed horizontally, it is important to provide a minimum 10 degree angle (motor in the down position), decrease the starts per day, and avoid open flow pump applications to prevent motor bearing damage. Depending upon the specific application, this will minimize the impact to motor life.

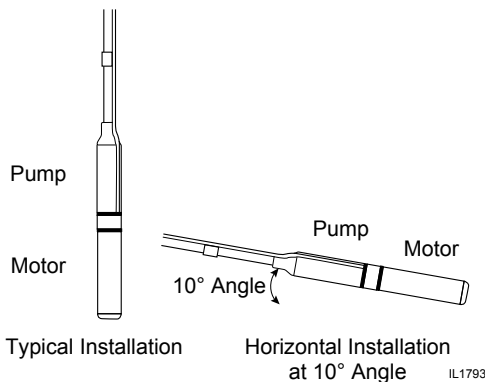

CHECK VALVE INSTALLATION

The F&W pump has a pre-assembled check valve within the discharge. Check valves effectively hold a column of water within the drop pipe which maintains water within the system. This prevents back spinning and water hammer. Additional check valves are required every 100 feet of vertical drop and one additional check valve within the horizontal run from the well site to the point of use.

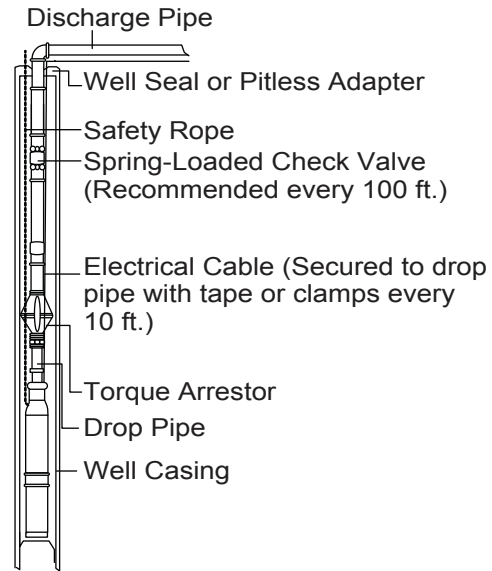

MAX WATER TEMPERATURE LIMITS

Submersible motors are designed to run within 86°F. water temperature without the need for a flow inducer sleeve.

If water temperature exceeds 86°F, installed in a large body of water, storage tank or large well casing, contact F&W Technical Service at 1-800-742-5044 for flow inducer sleeve application.

DROP PIPE INSTALLATION

Drop pipe threads and pump discharge must be tightened to 20 lb-ft to withstand loosening caused by rotational inertia generated from the starting torque of the pump.

To center the pump and protect the wire, a submersible cable guard is recommended. A torque arrestor is also suggested to minimize pump twisting caused by motor start torque. Plastic pipe installations should always use torque arrestors.

GROUNDING CONTROL BOXES AND PANELS

The National Electric Code requires that all control boxes and panel-grounding terminals be connected to the supply ground. A wire at least as large as the line conductor must be used to connect the grounding terminal to the electrical supply ground if the circuit has no grounding conductor and no metal conduit from the box to the supply panel.

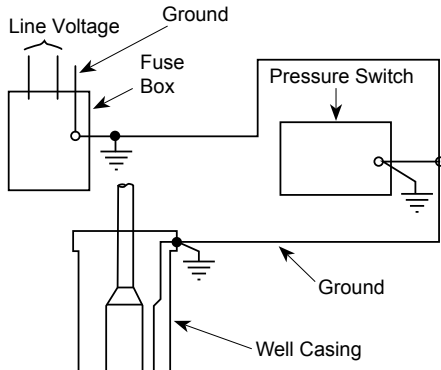

Note: It is recommended that all electrical work is completed by a licensed and trained professional. Follow all local and national codes.

⚠ WARNING: Failure to ground the box frame can result in a fatal electrical shock hazard if a circuit fault occurs.

⚠ WARNING: Serious or fatal electrical shock may result from failure to connect all metal plumbing, and the motor if outside a drilled well, to the power supply grounding terminal with wire no smaller than motor cable wires.

⚠ WARNING: This motor has not been approved for use in swimming areas.

PROPER GROUNDING OF SUBMERSIBLE MOTORS

1. The purpose of grounding any electrical apparatus is to prevent an electrical shock hazard if exposed metal becomes connected to an electrical circuit. This can occur from physical damage, or a breakdown in the insulation. Grounding prevents shock hazard by keeping exposed metal from reaching a voltage level which could endanger anyone coming in contact with the electrical equipment. Fault current is "drained" by the ground conductor, and if the fault is severe enough, the circuit will be opened by the fuse or circuit breaker.

2. Section 250-43 item (K) of the U.S. National Electrical Code (NEC) requires that motor operated water pumps, including the submersible type, regardless of voltage, shall be grounded. Section 26-954 of the Canadian Electrical Code specifically discusses grounding requirements for submersible pumps. Additional codes may vary in different states and localities, but all applicable national, state, and local codes should always be followed. Code questions should be directed to your local electrical inspector.

NOTE: Always disconnect all power when making ohmmeter checks and while pulling or installing a pump.

3. The submersible motor is normally grounded as follows:
 - a. Run an extra wire with the motor power conductors. This wire must be sized to meet Table 250-95 in the U.S. National Electrical Code.
 - b. The ground wire may be insulated or bare. If insulated, it must be green with or without yellow stripe(s). The ground wire may be part of, or separate from, the supply cable. It may be continuous or spliced above the pump along with the supply cable.
 - c. Connect the green or bare ground wire to the green ground wire of the submersible motor lead wire assembly.
 - d. Connect the other end of ground wire to the power supply grounding terminal or to the control panel ground bar if it is connected to the power supply ground.
 - e. All connections should be tight and corrosion resistant. Screws, lugs, or clamps should be made of corrosion resistant material.

In abnormally corrosive water, the ground wire connection could be compromised. In a corrosive water application, F&W advises the use of a GFCI with a 10m A trip point. Route the ground wire through the current sensing device with the motor supply leads to provide additional protection.

2-WIRE (PLUS GROUND) MOTOR OPERATION.

The 2 - wire motor has an internal switch designed to energize the start winding during motor start up. A control box should not be used.

The 2 - wire switch design requires a minimum time of 10 seconds between starts after power is removed from the motor. This is to insure that the internal switch resets, places the start winding into the circuit, and allows proper restart of the motor.

MAXIMUM COPPER CABLE LENGTHS IN FEET (SERVICE ENTRANCE TO MOTOR)

60°C Insulation

VOLTS	HP	WIRE SIZE (AWG)												
		14	12	10	8	6	4	3	2	1	0	00	000	0000
LENGTH IN FEET														
115	1/2	105	160	265	400	625	950	1150	1470	1780	2140	2475	3010	3510
	1/2	420	650	1070	1615	2500	3810	4620	5880	7115	8570			
	3/4	315	485	800	1210	1875	2855	3465	4410	5335	6425	7425		
230	1	245	375	615	930	1440	2200	2665	3390	4105	4945	5710		
	1.5 (3W)	205	320	530	800	1240	1905	2320	2965	3615	4375	5085		
	1.5 (2W)	190	295	490	740	1145	1745	2115	2690	3260	3925	4535		
	2	160	250	415	635	1000	1550	1905	2465	3060	3750	4415		

75°C Insulation

VOLTS	HP	WIRE SIZE (AWG)												
		14	12	10	8	6	4	3	2	1	0	00	000	0000
LENGTH IN FEET														
115	1/2	100	155	255	385	595	910	1105	1410	1710	2060	2384	2905	3400
	1/2	400	620	1020	1540	2390	3645	4420	5635	6836	8245			
	3/4	300	465	765	1155	1790	2735	3315	4230	5130	6185	7155	8720	
230	1	230	355	590	890	1380	2100	2250	3255	3945	4755	5500	6705	7845
	1.5 (3W)	200	305	505	765	1190	1825	2220	2840	3470	4205	4890	6010	7085
	1.5 (2W)	185	280	465	705	1095	1670	2025	2580	3130	3775	4368	5325	6230
	2	155	240	395	605	955	1480	1820	2360	2925	3590	4230	5315	6395

Lengths listed meet the NEC ampacity requirements for either individual conductors or jackets 60°C or 75°C cable and can be in conduit or direct buried.

NEC and local codes should be followed and observed for any other cable being used.

Cable lengths listed are calculated to allow a 5% voltage drop per NEC for alternating current. If a 3% voltage drop is desired, the values listed should be multiplied by 0.6 to obtain the maximum cable length.

MOTOR DIMENSIONS

		"L"	
HP	Wire	SS	E
1/2	2 and 3	10.10	10.47
3/4	2 and 3	11.23	11.60
1	2 and 3	12.10	12.47
1-1/2	2	15.56	N/A
1-1/2	3	14.06	14.35
2	3	15.56	N/A

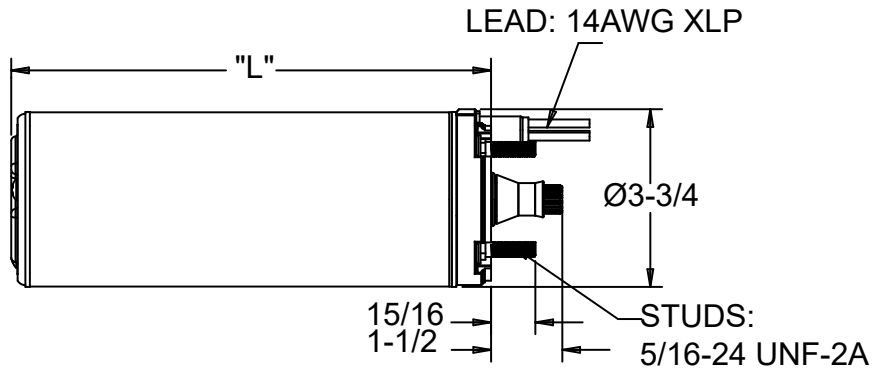

SUBMERSIBLE CONTROL BOXES

Model	HP	Volt	Amp	KW	Phase	Weight		Size (In.)
						Lbs.	KG	
022875	1/2	115	12	0.37	1	3	1.4	9 x 3.5 x 5.5
022876	1/2	230	6	0.37	1	3	1.4	9 x 3.5 x 5.5
022877	3/4	230	8	0.55	1	3	1.4	9 x 3.5 x 5.5
022878	1	230	10.4	0.75	1	3	1.4	9 x 3.5 x 5.5
022879	1-1/2	230	8.0/11.5	1.10	1	6.8	3.1	9.5 x 5.9 x 7.7
025242	2	230	13.2	1.50	1	7.1	3.2	9.5 x 5.9 x 7.7
025243	3	230	17	2.20	1	7.1	3.2	9.5 x 5.9 x 7.7
025244	5	230	27.5	3.70	1	10	4.5	15.7 x 5.9 x 7.8



FEATURES:

- Universal voltage/potential relay
- Side and bottom knockouts for easy wire installation
- Designed for indoor/outdoor installations NEMA 3R
- Interchangeable with industry control boxes
- Heavy-duty terminal block for secure connections

Deluxe 2, 3, & 5 HP Drive Features 025242, 025243, 025244

- **NEMA 3R Powder Coated Enclosure**
Rated for indoor / outdoor applications
- **Wall or Center Mount**
3-screw mounting pattern for wall or post mount applications
- **2-Pole Contactor in the 2HP and 3HP**
3-Pole Contactor in the 5HP
CSA / CE listed with quick-connect coil terminals
- **Premium Terminal Block**
The terminal block is well labeled and accepts #6 cable. Additional "hand space" provided for ease of wiring
- **2 Pump Protection Overloads**
Saves wear on the pump
- **Run & Start Capacitors**
Heavy duty & Made in the USA
- **Multiple Size Knockouts**
- **Overload Reset Buttons**
- **Relay**
Located front & center for easy access & removal. Reliable voltage relay. Made in the USA
- **Mechanical Ground**
Deluxe copper mechanical ground

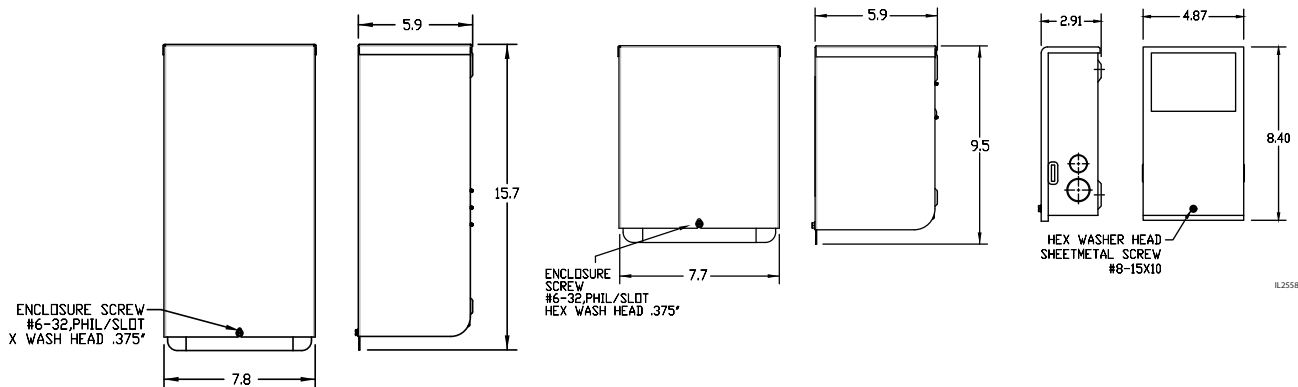

60HZ SINGLE PHASE MOTOR TABLE

	HP	KW	Voltage	Full Load			S.F.	Service Factor Load (Maximum Values)			Winding Res.	LR Amps	KVA Code
				Amps	Watts	%Eff F.L.		S.F. Amps	S.F. Watts	%Eff S.F.	Ohms		
2 Wire	1/2	0.37	115	10	740	50	1.6	12	960	62	1.1-1.4	64	R
	1/2	0.37	230	5	740	50	1.6	6	960	62	4.1-5.3	32	R
	3/4	0.55	230	6.8	1050	52	1.5	8	1350	61	2.9-3.7	40	N
	1	0.75	230	8.2	1350	56	1.4	10.4	1800	58	2.2-2.8	48	N
	1-1/2	1.1	230	10.6	1880	59	1.3	13.1	2390	60	1.6-2.0	65.5	M
3 Wire	1/2	0.37	115	10	740	50	1.6	12	960	62	M 1.1-1.4 A 4.3-5.3	48	M
	1/2	0.37	230	5	740	50	1.6	6	960	62	M 4.1-5.3 A 18.0-21.9	23	M
	3/4	0.55	230	6.8	1050	52	1.5	8	1350	61	M 2.9-3.7 A 11.0-13.5	39	M
	1	0.75	230	8.2	1350	56	1.4	10.4	1800	58	M 2.2-2.8 A 10.2-12.6	42	L
	1-1/2	1.1	230	10	1800	61	1.3	11.5	2280	63	M 1.7-2.2 A 7.8-9.6	52	J
	2	1.5	230	10	2380	63	1.25	13.2	2800	67	M 1.8-2.5 A 5.4-7.0	50	G

M = Main Res. (Yellow to Black)
 A= Aux. Res. (Yellow to Red)

SINGLE PHASE MOTOR FUSE SIZING

			Fuse or Circuit Breakers Amp MAXIMUM PER NEC		
	HP	Voltage	Standard Fuse	Dual Element Time Delay Fuse	Circuit Breaker
2 WIRE	1/2	115	35	20	30
	1/2	230	20	10	15
	3/4	230	25	15	20
	1	230	30	20	30
	1-1/2	230	35	20	30
3 WIRE	1/2	115	35	20	30
	1/2	230	20	10	15
	3/4	230	25	15	20
	1	230	30	20	25
	1-1/2	230	35	20	30
	2	230	40	20	30

F&W 4" Submersible Motors



MOTOR DATE CODES



F&W DATE CODE EXPLANATION

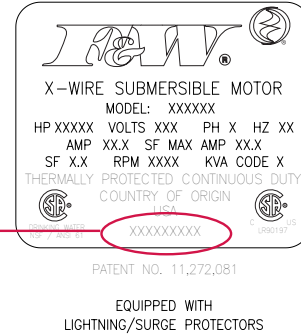
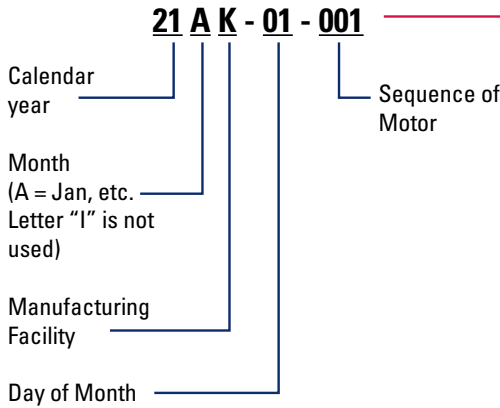

GENERATOR SIZING

Careful consideration needs to be made when sizing an engine driven generator for use with a well pump. Generators need to be sized to supply a minimum of 65% of the rated motor voltage during motor starting to ensure sufficient starting torque.

The type of the generator makes a difference when selecting a generator to power a well pump. Two types of generators are available: Internally regulated and externally regulated. Internally regulated generators have an additional winding within the generator. The additional winding automatically adjusts the output voltage by monitoring the output current. The majority of generators on the market today are externally regulated. These generators use an external voltage regulator that monitors the output voltage. When a motor starts up and the voltage drops, the regulator boosts the output voltage of the generator.

When operating a pump with a generator, the generator needs to be started in advance of starting the pump motor. In addition, to help prevent motor bearing damage, stop the pump before turning off the generator.

The table below only represents typical minimum generator requirements for starting and running a submersible motor. Contact the generator manufacturer for detailed sizing considerations.

⚠ WARNING: Transfer switches are required when a generator is used as a back-up on power lines. Consult your power provider for proper use and approval.

ENGINE DRIVEN GENERATORS

Motor HP Rating	Externally Regulated		Internally Regulated	
	KW	KVA	KW	KVA
1/2	2	2.5	1.5	1.9
3/4	3	3.8	2	2.5
1	4	5	2.5	3.2
1.5	5	6.3	3	3.8
2	7.5	9.4	4	5

Note: The table provided applies to 3-Wire motors.
 If sizing for 2-Wire motors, multiply the value shown by 1.5.

BUCK-BOOST TRANSFORMERS

A buck-boost transformer is the ideal solution for changing line voltage by small amounts when the power available for a motor is not within the correct range. These transformers can be connected for a wide range of voltage combinations. The most common use is to buck (lower) or boost (raise) the supply voltage a small amount, usually 5 to 27%. When a buck-boost transformer has the primary and secondary windings connected as an autotransformer, only the secondary windings are transforming voltage and current. This is the reason buck-boost transformers can supply a load with a much larger KVA rating than the nameplate indicates. Tables published by transformer manufactures can provide a wide range of voltage change. The table provided is based on boosting voltage by 10% as recommended by F&W. It shows the minimum rating of KVA that the transformer needs as well as the common standard transformer KVA generally available.

Note: Contact transformer manufacturer for details and correct sizing when planning to raise or lower the voltage for a range other than the 10% boost listed.

Buck-Boost transformer Sizing (10% Boost)

Motor HP	1/2	3/4	1	1.5	1.5 (2-wire)	2
Load KVA	1.38	1.84	2.40	2.65	3.01	3.04
Minimum Transformer KVA	0.14	0.19	0.24	0.27	0.31	0.31
Standard Transformer KVA	0.25	0.25	0.25	0.50	0.50	0.50

CYCLING ON / OFF

Motor life can be reduced with excessive cycling of the pump due to the current in-rush at start up. Frequent starts increase motor temperature, create bearing and seal wear, and shaft spline fatigue. While typical residential cycling is estimated at 25 to 50 starts per 24 hour period, recommended maximum starts for longer life should not exceed 1 start per 5 minutes.

SHAFT HEIGHT

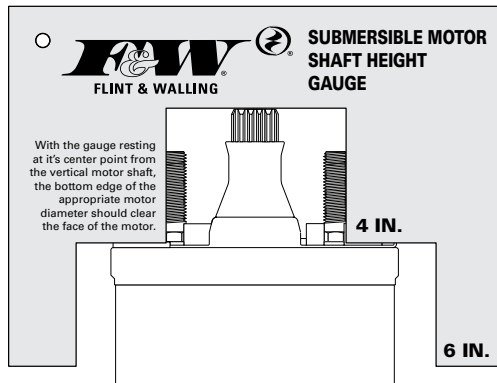

With the 024456 gauge resting at it's center point from the vertical motor shaft, the bottom edge of the appropriate motor diameter should clear the face of the motor.

IDENTIFICATION OF CABLE COLOR

(Single Phase Only)

If the colors on the individual drop cables cannot be determined and the leads cannot be positively identified, proceed as follows:

1. Disconnect all three drop cables from the control box. For temporary identification, tie a numbered tag to each cable (1, 2, 3).
2. Using an ohmmeter, check the resistance between cables as follows:

Unknown Value	Known Value
Cable 1 to Cable 2	Lowest - Black to Yellow
Cable 1 to Cable 3	Intermed. - Red to Yellow
Cable 2 to Cable 3	Highest - Black to Red

NOTE: The "yellow" cable is giving the lowest and intermediate readings and the "red" cable gives highest and intermediate readings.

Example:

- 1 to 2 gives 7 ohms (highest reading)
- 1 to 3 gives 5 ohms (intermediate reading)
- 2 to 3 gives 2 ohms (lowest reading)
- Cable 3 gave both intermediate and lowest reading
- Cable 3 is the yellow cable
- Cable 1 gave both highest and intermediate readings
- Cable 1 is the red cable
- Cable 2 is the black cable

The actual ohm values are not important. The method works regardless of the actual ohm readings; what matters is which reading is highest, which intermediate, and which lowest.

F&W

4" Submersible Motors



SINGLE PHASE CONTROL BOX CHECKING AND REPAIRING PROCEDURES

CAUTION: Turn power off and discharge capacitors before using ohmmeter.

TEST PROCEDURE

General Procedures	Disconnect line. Inspect for damaged or burned parts, loose connections, etc. Check for mis-connections using diagram in control box. If problem has not been found, check motor per Motor Data Chart and control box as indicated below.
Use of Ohmmeter	Use a calibrated or certified digital multimeter.
Ground (Insulation Resistance) Test	Multimeter selected to highest OHM meter scale. Terminal connections: Multimeter lead to "ground" terminal on control box and touch other lead to each of the other terminals on terminal board. Multimeter reading should indicate (∞) or max open circuit limits.
Overload Protector	Multimeter selected to lowest OHM meter scale. Terminal connections: Connect one multimeter lead to Terminal Black and other lead to L1. Multimeter reading: Should be 0 to 0.5 ohms maximum.
Capacitor Tests	Start Capacitor Multimeter selected to 10k – 20k Ohm meter scale. Terminal Connections: One multimeter lead to relay terminal #1 and the other to black terminal on the terminal board. Ohm reading: The multimeter will briefly read a low resistance and climb back to infinity/max open circuit reading. If reading is not as above, the capacitor is likely shorted or open and needs to be replaced. Run Capacitor Multimeter selected to 10k – 20k Ohm meter scale. Disconnect the Red lead from the run capacitor terminal. Terminal Connections: One multimeter lead to the terminal on the capacitor that the red lead was connected to and the other to black terminal on the terminal board. Ohm reading: The multimeter will briefly read a low resistance and climb back to the infinity/max open circuit reading. If reading is not as above the capacitor is likely shorted or open and needs to be replaced. Caution: The tests in this guide for capacitors and relays should be considered indicative, but not irrefutable. A capacitor for example may not show as open or shorted, but may have lost some of its capacitance and may no longer be capable of performing its purpose.
Relay Coil Test (potential relays only)	Multimeter selected to 10k – 20k Ohm meter scale. Terminal Connections: Connect one multimeter lead to #2 and the other to #5 on the relay. For 230 Volt boxes, the meter should read 4.5-7.0 K Ohms. For 115 Volt boxes, the meter should read 2.9 4.9 K Ohms.
Relay Contact Test	Multimeter selected to lowest Ohm meter scale. Terminal Connections: Connect one multimeter lead to #1 and the other to #2 on the relay. The meter should read Zero ohms.

MULTIMETER TESTS

Insulation and Continuity Test

1. This test is recommended when the splicing is complete and pump is being test run in a tank of water. This test can be repeated after installation in well, but before the final electrical hook-up is made to the control box or pressure switch.
2. Confirm multimeter ohmmeter function by clipping the leads together and verifying resistance readings $<0.2\Omega$
3. Clip one multimeter lead to bare cable end.
4. Clip the other lead to motor ground wire with pump and cable submerged.
5. A reading of less than 1,000,000 ohms indicates that cable or splice is grounded. Slowly raise cable from the water at the multimeter end. When trouble spot moves clear of the water, OHM reading will increase towards (∞) or max open reading of multimeter. In an old installation with the pump in the well, a reading of 20,000 ohms or less indicates a breakdown in the insulation; in this case pull the pump.

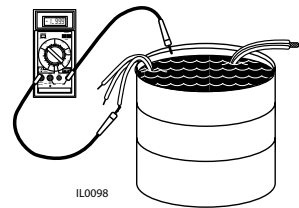

IL0098

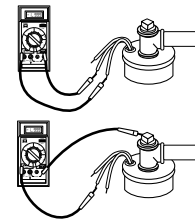

IL0099

TROUBLESHOOTING CHART

Symptom	Possible Cause(s)	Corrective Action
Circuit breaker trips or fuses blow when motor starts.	1. Incorrect voltage	1. Contact power company if voltage is incorrect after first checking for correct wire size. See Wire Size Chart.
	2. Incorrect fuses or circuit breaker.	2. Replace with correctly sized components.
	3. Defective pressure switch	3. Replace pressure switch or clean contacts.
	4. Control box malfunction	4. Correct faulty wiring or tighten loose contacts.
	5. Bound pump	5. Sand bound pump can sometimes be corrected by temporarily reversing black and red leads in control box then returning to normal. If pump does not rotate freely, it must be pulled and cleaned or realigned and the well condition corrected.
	6. Defective cable or motor winding	6. The pump must be pulled and the cable disconnected and inspected. Damaged cable should be correctly spliced or replaced. If cable is good, the motor winding is grounded
	7. Shorted or open motor winding	7. The pump must be pulled and motor or drop cable repaired or replaced.
Motor runs but circuit breaker, fuses or motor overload trips.	1. Incorrect voltage	1. Contact power company.
	2. Overheated protectors	2. Shade box, provide ventilation or move box away from heat source.
	3. Improperly wired control box	3. Confirm motor and line connections.
	4. Defective motor or cable	4. If ground, short or open circuit is indicated pump must be pulled for repair.
	5. Defective pump	5. Pull pump, clean and repair to ensure pump staging is free of excess sand or debris.
Motor does not start and circuit breaker or fuses not tripped.	1. No power	1. Replace fuses or reset circuit breaker. Contact power company if no power is reaching box.
	2. Defective pressure switch	2. Clean contact points or replace switch.
	3. Defective wiring	3. Correct faulty wiring or connections/splices.
Pump runs, but delivers little or no water.	1. Air locked pump	1. Not enough water over pump. Raise and lower the pump at a fast rate to purge air from pump body.
	2. Low water level in well	2. Throttle pump delivery through restricting valve. Lower pump setting if depth of well is adequate.
	3. Check valve stuck or installed improperly	3. Replace or reinstall properly, ensure water check valve arrow oriented with flow.
	4. Leak in drop pipe	4. Raise pipe, check for leak and replace damaged section.
	5. Pump screen blocked	5. Clean screen and reset at less depth. It may be necessary to clean well.
	6. Worn pump	6. Pull pump and replace staging or pump end.
Pump keeps running	1. Pressure switch	1. Clean points or replace switch. Verify pressure switch setting and function.
	2. Low level well	2. Throttle pump output or reset pump to lower level. Do not lower if sand may clog pump.
	3. Leak in system	3. Replace damaged section. Replace all piping and joints to eliminate leaks.
	4. Misapplied pump	4. Verify pump depth/static water level vs. pump performance curve. For guidance, contact Tech Support at 1-800-742-5044.
Pump starts too often	1. Pressure switch	1. Reset limits or replace switch.
	2. Leak in system	2. Repair or replace tank or pipes.
	3. Check valve	3. Replace if column of water leaking by check valve.
	4. Water-logged tank	4. Replace tank.
	5. Pressure tank too small	5. Install larger tank.

F&W Motor Data

Single & Three Phase Jet/Centrifugals



SINGLE PHASE MOTOR DATA 60 HZ 3450 RPM (1) CHART A

Motor Model No.	HP	Motor Voltage	Service Factor	Service Factor Motor AMPS		Locked Rotor Motor AMPS		KVA Code Letter
				115V	230V	115V	230V	
98J103	1/3	115/230	1.75	8.6	4.3	26.0	13.0	K
98J105, 98S105	1/2	115/230	1.60	13.0	6.5	36.0	18.0	K
98J107, 98S107	3/4	115/230	1.50	14.0	7.0	52.0	26.0	K
98H107	3/4	115/230	1.86	18.0	9.0	78.0	39.0	P
98J110, 98S110	1	115/230	1.40	18.0	9.0	78.0	39.0	L
98H110	1	115/230	1.95	21.0	10.5	98.0	49.0	N
98J115, 98S115	1-1/2	115/230	1.30	21.0	10.5	98.0	49.0	J
98H115	1-1/2	115/230	1.66	25.0	12.5	116.0	58.0	K
98J120, 98S120	2	115/230	1.25	25.0	12.5	116.0	58.0	H
98J610	1	230	1.70	-	8.1	-	39.0	L
98J615	1-1/2	230	1.30	-	10.2	-	49.0	J
98J630, 98S630	3	230	1.00	-	13.5	-	53.0	D

(1) Thermal Overload Protected - Automatic Reset

SINGLE PHASE MOTOR DATA 50 HZ 2875 RPM(1) CHART B

Motor Model No.	HP	Motor Voltage	Service Factor	Service Factor Motor AMPS		Locked Rotor Motor AMPS		KVA Code Letter
				110V	220V	110V	220V	
98J003	1/3	110/220	1.75	7.6	3.8	44.0	22.0	R
98J005, 98S005	1/2	110/220	1.60	10.0	5.0	48.0	24.0	M
98J007, 98S007	3/4	110/220	1.50	14.4	7.2	64.0	32.0	L
98J010, 98S010	1	110/220	1.40	16.4	8.2	72.0	36.0	K
98J015, 98S015	1-1/2	110/220	1.30	23.6	11.8	104.0	52.0	K
98J820, 98S820	2	220	1.00	-	13.2	-	55.0	H

(1) Thermal Overload Protected - Automatic Reset

THREE PHASE MOTOR DATA 60/50(1 2) HZ 3450/2875 RPM CHART C

Motor Model No.	HP	Motor Voltage	Service Factor	Service Factor Motor AMPS		Locked Rotor Motor AMPS		KVA Code Letter
				230V	460V	230V	460V	
98J305, 98S305	1/2	208-230/460	1.60	3.5	1.75	19.0	9.5	K
98J307, 98S307	3/4	208-230/460	1.50	3.5	1.75	19.0	9.5	K
98J310, 98S310	1	208-230/460	1.40	4.5	2.25	26.9	13.5	K
98J315, 98S315	1-1/2	208-230/460	1.30	5.7	2.85	33.5	16.8	K
98J320, 98S320	2	208-230/460	1.25	7.4	3.70	44.0	22.0	K
98J330, 98S330	3	208-230/460	1.00	9.8	4.90	48.0	24.0	D

(1) 3 HP, 3 phase motors are operable on 60Hz only - 3450 RPM

(2) Thermal Overload Protector - Not Supplied

Three phase motors must be installed with a properly sized magnetic or manual starter, both with properly sized heaters. Install starter following the instruction of the starter manufacturer.

MINIMUM WIRE SIZE CHART (GAUGE) - COPPER WIRE CHART D

Motor HP	Volts	Phase	Distance in Feet from Motor to Service Panel					Breaker Size (Amps)
			0-50	50-100	100-150	150-200	200-300	
0.33	115/230	1	14/14	14/14	12/14	10/14	8/14	15/15
0.5	115/230	1	14/14	12/14	10/14	8/14	6/12	15/15
0.75	115/230	1	14/14	10/14	8/14	8/14	6/12	15/15
1	115/230	1	12/14	10/14	8/14	6/12	4/10	20/15
1	230	1	14	14	14	12	10	15
1.5	115/230	1	10/14	8/14	6/14	6/12	4/10	30/15
1.5	230	1	14	14	14	12	10	15
2	115/230	1	10/14	8/14	6/12	4/10	4/10	30/15
3	230	1	12	12	10	10	8	20
0.75	230/460	3	14/14	14/14	14/14	14/14	14/14	15/15
1	230/460	3	14/14	14/14	14/14	14/14	14/14	15/15
1.5	230/460	3	14/14	14/14	14/14	14/14	12/14	15/15
2	230/460	3	14/14	14/14	14/14	12/14	12/14	15/15
3	230/460	3	14/14	14/14	12/14	12/14	10/14	15/15

Maximum 5% voltage drop calculated by conductor resistance in NEC Table 8 and minimum ampacity rating as defined by NEC 430.22

WIRING DIAGRAMS JET / CENTRIFUGAL MOTORS

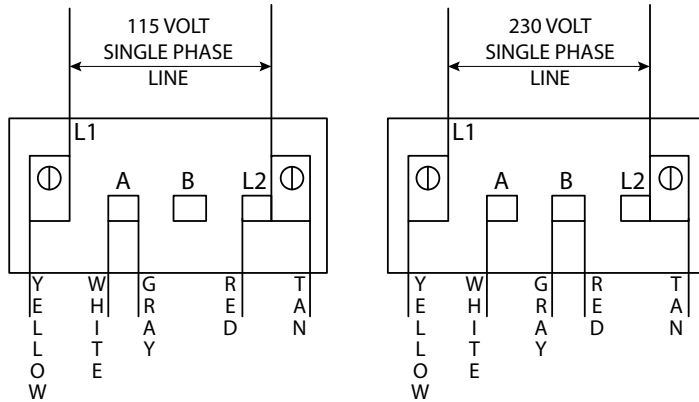

NOTE: Dual voltage motor, change the red and gray wire to voltage required.

Figure 2 - Wiring Diagram for Single Phase 1/3 - 2 HP Motors

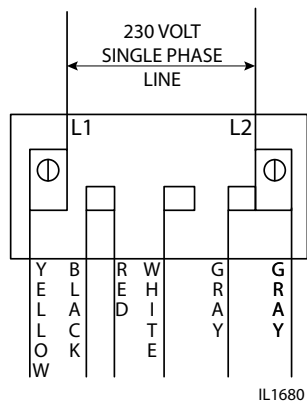

NOTE: Single voltage (230V) motor, and cannot be connected to 115V.

Figure 3 - Wiring Diagram for Single Phase 230V only 1, 1-1/2 & 3 HP Motors

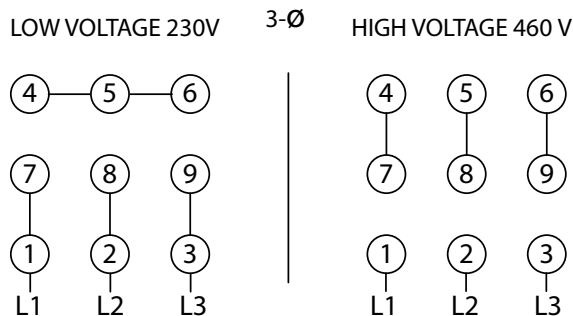

IL0770

1 - Tan	4 - Yellow	7 - Purple
2 - Red	5 - Black	8 - Gray
3 - Orange	6 - Blue	9 - White

CONNECTION FOR 3 PHASE, 9 LEADS. IF YOUR 3 PHASE LEADS ARE COLOR CODED, MATCH NUMBER ABOVE TO THE CORRESPONDING COLOR.

NOTE: To reverse rotation, interchange any two incoming lines (Power) leads.

Figure 4 - Wiring Diagram for Three Phase Motors

Cable Selection



SINGLE PHASE TWO OR THREE WIRE CABLE, 60 HZ (SERVICE ENTRANCE TO MOTOR)

Motor Rating		AWG Copper Wire Size												
Volts	HP	14	12	10	8	6	4	3	2	1	0	00	000	0000
115	1/3	130	210	340	540	840	1300	1610	1960	2390	2910	3540	4210	5060
	1/2	100	160	250	390	620	960	1190	1460	1780	2160	2630	3140	3770
230	1/3	550	880	1390	2190	3400	5250	6520	7960	9690	11770			
	1/2	400	650	1020	1610	2510	3880	4810	5880	7170	8720			
	3/4	300	480	760	1200	1870	2890	3580	4370	5330	6470	7870		
	1	250	400	630	990	1540	2380	2960	3610	4410	5360	6520		
	1-1/2	190	310	480	770	1200	1870	2320	2850	3500	4280	5240		
	2	150	250	390	620	970	1530	1910	2360	2930	3620	4480		
	3	120*	190	300	470	750	1190	1490	1850	2320	2890	3610		
	5	0	0	180*	280	450	710	890	1110	1390	1740	2170	2680	
	7-1/2	0	0	0	200*	310	490	610	750	930	1140	1410	1720	
	10	0	0	0	0	250*	390	490	600	750	930	1160	1430	1760
	15	0	0	0	0	170*	270*	340	430	530	660	820	1020	1260

1 Foot = .3048 Meter

THREE PHASE THREE WIRE CABLE, 60 HZ 200 AND 230 VOLTS (SERVICE ENTRANCE TO MOTOR)

Motor Rating		AWG Copper Wire Size												MCM Copper Wire Size					
Volts	HP	14	12	10	8	6	4	3	2	1	0	00	000	0000	250	300	350	400	500
200V 60HZ Three Phase Three Wire	1/2	710	1140	1800	2840	4420													
	3/4	510	810	1280	2030	3160													
	1	430	690	1080	1710	2670	4140	5140											
	1-1/2	310	500	790	1260	1960	3050	3780											
	2	240	390	610	970	1520	2360	2940	3610	4430	5420								
	3	180	290	470	740	1160	1810	2250	2760	3390	4130								
	5	110*	170	280	440	690	1080	1350	1660	2040	2490	3050	3670	4440	5030				
	7-1/2	0	0	200	310	490	770	960	1180	1450	1770	2170	2900	3150	3560				
	10	0	0	0	230*	370	570	720	880	1090	1330	1640	1970	2390	2720	3100	3480	3800	4420
	15	0	0	0	160*	250*	390	490	600	740	910	1110	1340	1630	1850	2100	2350	2570	2980
	20	0	0	0	0	190*	300*	380	460	570	700	860	1050	1270	1440	1650	1850	2020	2360
25	0	0	0	0	0	240*	300*	370*	460	570	700	840	1030	1170	1330	1500	1640	1900	
30	0	0	0	0	0	0	250*	310*	380*	470	580	700	850	970	1110	1250	1360	1590	
230V 60HZ Three Phase Three Wire	1/2	930	1490	2350	3700	5760	8910												
	3/4	670	1080	1700	2580	4190	6490	8060	9860										
	1	560	910	1430	2260	3520	5460	6780	8290										
	1-1/2	420	670	1060	1670	2610	4050	5030	6160	7530	9170								
	2	320	510	810	1280	2010	3130	3890	4770	5860	7170	8780							
	3	240	390	620	990	1540	2400	2980	3660	4480	5470	6690	8020	9680					
	5	140*	230	370	590	920	1430	1790	2190	2690	3290	4030	4850	5870	6650	7560	8460	9220	
	7-1/2	0	160*	260	420	650	1020	1270	1560	1920	2340	2870	3440	4160	4710	5340	5970	6500	7510
	10	0	0	190*	310	490	760	950	1170	1440	1760	2160	2610	3150	3590	4100	4600	5020	5840
	15	0	0	0	210*	330	520	650	800	980	1200	1470	1780	2160	2440	2780	3100	3400	3940
	20	0	0	0	0	250*	400	500	610	760	930	1140	1380	1680	1910	2180	2450	2680	3120
25	0	0	0	0	0	320*	400	500	610	750	920	1120	1360	1540	1760	1980	2160	2520	
30	0	0	0	0	0	0	260*	330*	410*	510	620	760	930	1130	1280	1470	1650	1800	2110
460V 60HZ Three Phase Three Wire	1/2	3770	6020	9460															
	3/4	2730	4350	6850															
	1	2300	3670	5770	9070														
	1-1/2	1700	2710	4270	6730														
	2	1300	2070	3270	5150	8050													
	3	1000	1600	2520	3970	6200													
	5	590	950	1500	2360	3700	5750												
	7-1/2	420	680	1070	1690	2640	4100	5100	6260	7680									
	10	310	500	790	1250	1960	3050	3800	4680	5750	7050								
	15	0	340*	540	850	1340	2090	2600	3200	3930	4810	5900	7110						
	20	0	0	410*	650	1030	1610	2000	2470	3040	3730	4580	5530						
	25	0	0	0	530*	830	1300	1620	1990	2450	3010	3700	4470	5430					
	30	0	0	0	430*	680	1070	1330	1640	2030	2490	3060	3700	4500	5130	5860			
	40	0	0	0	0	500*	790	980	1210	1490	1830	2250	2710	3290	3730	4250			
	50	0	0	0	0	0	640*	800	980	1210	1480	1810	2190	2650	3010	3420	3830	4180	4850
	60	0	0	0	0	0	540*	670*	830*	1020	1250	1540	1850	2240	2540	2890	3240	3540	4100
	75	0	0	0	0	0	0	0	680*	840*	1030	1260	1520	1850	2100	2400	2700	2950	3440
100	0	0	0	0	0	0	0	0	620*	760*	940*	1130	1380	1560	1790	2010	2190	2550	
125	0	0	0	0	0	0	0	0	0	740*	890*	1000*	1220	1390	1560	1700	1960		
150	0	0	0	0	0	0	0	0	0	0	760*	920	1050*	1190*	1340	1460	1690		
175	0	0	0	0	0	0	0	0	0	0	0	810	930*	1060*	1190*	1300	1510		
200	0	0	0	0	0	0	0	0	0	0	0	0	810*	920*	1030*	1130*	1310		

⚠ CAUTION Use of wire size smaller than listed will void warranty.

FOOTNOTES:

- (1) Lengths marked * meet the U.S. National Electrical Code ampacity only for individual conductor 60°C cable. Only the lengths without * meet the code for jacketed 60°C cable. Local code requirements may vary.
- (2) Maximum lengths shown maintain motor voltage at 95% of service entrance voltage, running at maximum nameplate amperes. If service entrance voltage will be at least motor nameplate voltage under normal load conditions, 50% additional length is permissible for all sizes.

- (3) This table is based on copper wire. If aluminum wire is used, it must be two sizes larger. Example: When the table calls for #12 copper wire, you would use #10 aluminum wire.
- (4) Single phase control boxes may be connected at any point of the total cable length.
- (5) Cable #14 to #0000 are AWG sizes.

OVERLOAD PROTECTION REQUIRED FOR 4", 6" & 8" SUBMERSIBLE MOTORS – 60 CYCLE – 3 PHASE

MOTOR			
HP	VOLTS	F&W PART NO.	SERVICE FACTOR AMPS
4" FRANKLIN SUBMERSIBLE MOTORS – 60 HZ – 3 PHASE			
1 1/2	200	137457	6.8
	230	137458	5.9
	460	137460	3.1
2	200	137461	9.3
	230	137462	8.1
	460	137464	4.1
3	200	M137465	12.5
	230	M137466	10.9
	460	M137468	5.5
5	200	M137469	20.5
	230	M137470	17.8
	460	M137472	8.9
7 1/2	200	M137473	30.5
	230	M137474	26.4
	460	M137476	13.2
6" & 8" FRANKLIN SUBMERSIBLE MOTORS – 60 HZ – 3 PHASE			
5	200	133492	20.0
	230	133493	15.0
	460	133494	8.8
7 1/2	200	130646	28.3
	230	126552	24.6
	460	128876	12.3
10	200	130647	37.0
	230	126554	32.2
	460	128875	16.1
15	200	130648	54.4
	230	126555	47.4
	460	128884	23.7
20	200	130649	69.7
	230	128754	60.6
	460	128888	30.3
25	200	130650	86.3
	230	128755	75.0
	460	128890	37.5
30	230	128964	90.4
	460	128965	45.2
40	460	021003	61.6
50	460	021004	77.0

CAUTION: WARRANTY ON THREE PHASE SUBMERSIBLE MOTORS IS VOID UNLESS PROPER QUICK TRIP PROTECTORS ARE USED ON ALL 3 LEAD WIRES.

The characteristics of submersible motors are different from standard motors and special overload protection is required. If the motor is stalled, the overload protector must trip within approximately 10 seconds to protect the motor windings. In the three phase submersible motors, the installer must provide the SPECIAL EXTRA QUICK TRIP PROTECTORS. Per heater manufacturer's recommendations, heaters are for ambient compensated starter boxes; if they are not used, nuisance tripping (over protection) may be experienced at high temperatures and no protection will exist at low temperatures.

Overload protectors (heaters) for motors of "200-230 volt" ratings should be selected for each installation based on the line voltage measured at the control panel.

CENTRIFUGAL AND JET PUMP MOTORS

MOTOR				
MFGR.	HP	VOLTS	SERVICE FACTOR AMPS	
SINGLE PHASE, 60 HZ MOTORS				
BALDOR	3	230	16.8	
	5	230	21.5	
THREE PHASE, 60 HZ MOTORS				
F&W	1/2, 3/4	208/230	3.5	
		460	1.75	
	1	208/230	4.5	
		460	2.25	
	1-1/2	208/230	5.7	
		460	2.9	
	2	208/230	7.4	
		460	3.7	
	3	208/230	9.8	
		460	4.9	
	BALDOR	3	208/230	9.0
			460	4.5
5		208/230	14.0	
		460	7.0	
7-1/2		208/230	21.0	
		460	10.5	

CAUTION: WARRANTY ON THREE PHASE MOTORS IS VOID UNLESS PROPER QUICK TRIP PROTECTORS ARE USED ON ALL 3 LEAD WIRES.

4" SUBMERSIBLE PUMP REPAIR PARTS (Nov. '06 & Later)

(For Pricing Refer To Repair Parts Price List)

5 - 7 - 10 - 19 & 27 GPM SERIES

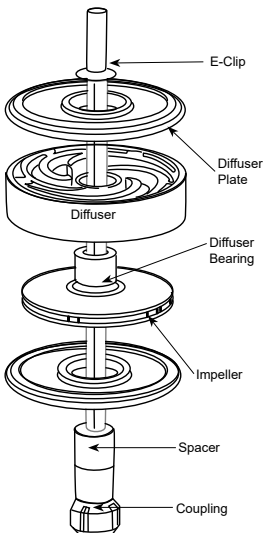
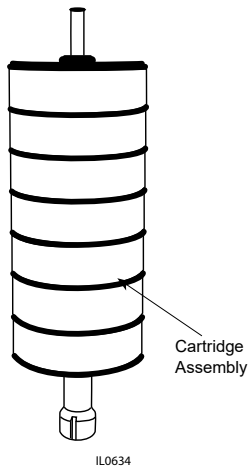
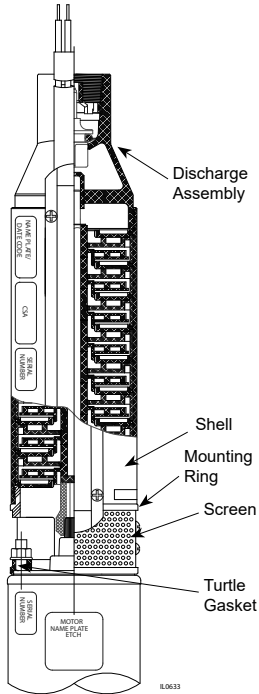

DESCRIPTION	QTY.	STAINLESS STEEL	CAST IRON
		PART NUMBER	
Discharge Assembly	1	020517	020510
Seat	1	Not Required	020515
Bearing	1	020053	
Poppet w/Buna O-ring	1	024528	
Poppet Retainer	1	024414	
Mounting Ring	1	020519	020523
Screen	1	020526A	
Fastener Kit (Motor mounting nuts and screen screws)	1	022017	
Turtle Gasket	1	025481	

GPM		5	7	10	19	27
NUMBER OF STAGES	1/2 HP	15	10	8	5	-
	3/4 HP	21	14	12	7	6
	1 HP	26	18	15	9	7
	1-1/2 HP	35	24	20	12	10
	2 HP	-	30	26	16	12
	3 HP	-	-	34	22	17
5 HP	-	-	-	-	32	29

DESCRIPTION	HP	QTY.	PART NUMBER				
Cartridge Assembly *	1/2	1	022227	022231	022236	022242	-
	3/4		022228	022232	022237	022243	022249
	1		022229	022233	022238	022244	022250
	1-1/2		022230	022234	022239	022245	022251
	2		-	022235	022240	022246	022252
	3		-	-	022241	022247	022253
5	-	-	-	022248	022254	-	
Cable Guard Stainless Steel**	1/2	1	020894	139015	020868	020865	-
	3/4		020880	022285	020873	020867	020866
	1		020885	020877	020876	020871	020868
	1-1/2		020889	020883	020882	020893	020872
	2		-	020888	020887	020879	020874
	3		-	-	020891	020886	020881
5	-	-	-	020892	020890	-	
Cable Guard Thermoplastic***	1/2	1	020853	136386	020841	020837	-
	3/4		020860	022212	020850	020840	020839
	1		SS	020857	020856	020845	020841
	1-1/2		SS	SS	020862	020852	020849
	2		-	SS	SS	020858	137527
	3		-	-	SS	SS	020861
5	-	-	-	SS	SS	SS	
Shell - Stainless Steel	1/2	1	020721	020710	020705	020698	-
	3/4		020733	022284	020718	020704	020701
	1		020738	020727	020726	020713	020705
	1-1/2		020744	020736	020735	020720	020717
	2		-	022210	020742	020730	020723
	3		-	-	020746	020739	020734
5	-	-	-	020747	020745	-	
Shell - Carbon Steel "G" Series Only	1/2	1	022203	022120	021538	-	-
	3/4		022204	022123	022122	-	021538
	1		-	-	022125	021540	022121

(*) Cartridge assembly includes: Impellers, diffusers, hex shaft w/coupling, bearing and slinger

(**) Part numbers for units fitted with SS cable guard

(***) Part numbers for units fitted with thermoplastic cable guard

FORM NO. FW0021
0821
SUPERSEDES 0811
Page 2 of 2

CARTRIDGE ASSEMBLY COMPONENTS (Nov '06 & Later)							
(For Pricing Refer To Repair Parts Price List)							
5 - 7 - 10 - 19 & 27 GPM SERIES							
GPM		5	7	10	19	27	
NUMBER OF STAGES	1/2 HP	15	10	8	5	-	
	3/4 HP	21	14	12	7	6	
	1 HP	26	18	15	9	7	
	1-1/2HP	35	24	20	12	10	
	2 HP	-	30	26	16	12	
	3 HP	-	-	34	22	17	
	5 HP	-	-	-	32	29	
DESCRIPTION	HP	QTY	PART NUMBER				
Spacer		1	138724	138724	138724	138724	138764
Impeller		*	130861	133728	130855	131330	133423
Diffuser		*	130865	130865	130859	131333	133424
Diffuser Bearing		*	130854	130854	130854	130854	130854
Diffuser Plate		**	130858	130858	130858	131342	131342
E-Clip		1	139439	139439	139439	139439	139439
Shaft & Coupling Assembly	1/2	1	022207	020764	020762	020570	-
	3/4		022211	022208	020770	020761	020757
	1		020789	020778	020777	020767	020762
	1-1/2		020797	020787	020786	020803	022048
	2		-	020794	020793	020781	020775
	3		-	-	-	020799	020790
5	-	-	-	-	020800	020798	

(*) For quantity required - See number of stages

(**) Qty. - One plus number of stages

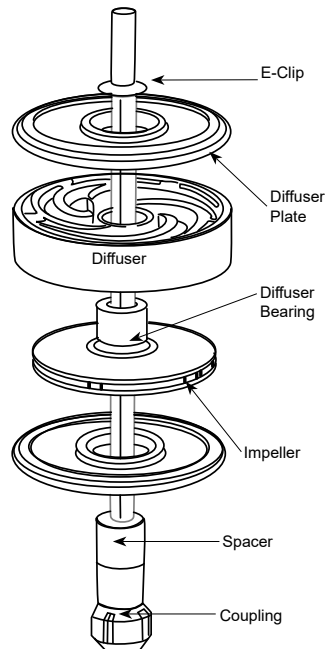

SUBMERSIBLE PUMP REPAIR PARTS (For Pricing Refer to Repair Parts Price List) 35 - 55 & 85 GPM Series

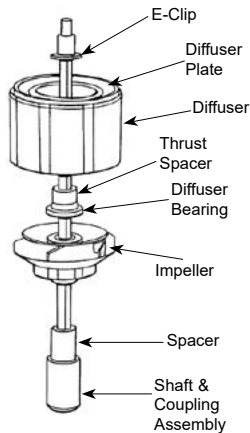
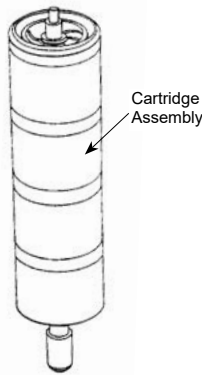
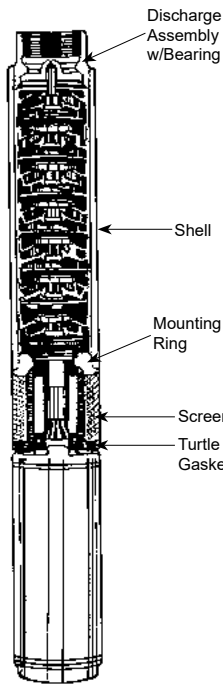

DESCRIPTION	QTY	CAST IRON	SS Nov '05 & later
Discharge Assembly	1	020525	020528
Bearing	1	130867	130867
Mounting Ring	1	139417	020521
Screen	1	137733	137733
Fastener Kit *	1	138781	137746
Turtle Gasket	1	025481	025481

GPM		35	55	85
NUMBER OF STAGES	1 HP	4	N/A	N/A
	1-1/2 HP	5	4	N/A
	2 HP	7	5	4
	3 HP	10	7	6
	5 HP	16	11	10
	7-1/2 HP	23	18	15

DESCRIPTION	HP	QTY	PART NO.		
			All CI and SS Nov '05 and later		
Cartridge Assembly (Includes impellers, diffuser, hex shaft w/coupling, bearing and e-clip)	1	1	133134	N/A	N/A
	1-1/2		133135	133141	N/A
	2		133136	133142	133619
	3		133137	133143	133626
	5		133587	133145	133630
7-1/2	133140	133146	133637		
Cable Guard	1	1	136385	N/A	N/A
	1-1/2		136386	138767	N/A
	2		020548	020550	136408
	3		020549	136388	136390
	5		137093	137090	137094
7-1/2	137098	137099	137100		
Shell	1	1	133035	N/A	N/A
	1-1/2		133036	020353	N/A
	2		020545	130909	133616
	3		139004	138055	133038
	5		139008	130913	131530
7-1/2	139012	139027	139040		

CARTRIDGE ASSEMBLY COMPONENTS only available for Nov. 17 and later					
Spacer	1	024887	024888	024891	
>Diffuser Plate, Mtg. Ring	1	135735	135735	135736	
Impeller	•	024884	024885	024886	
Impeller Short Hub	•	N/A	N/A	N/A	
Diffuser	•	132991	132992	133556	
Diffuser Bearing	•	130854	130854	130854	
Diffuser Plate	•	132995	132995	133557	
Thrust Spacer	†	†	†	†	
E-Clip	1	139439	139439	139439	
Shaft & Coupling Assembly	1	1	133047	N/A	N/A
	1-1/2		133049	133747	N/A
	2		020772	020804	020771
	3		024892	020779	020784
	5		020795	020807	020796
7-1/2	020806	020802	020836		

(•) For quantity required, see number of stages
(>) Not shown
(†) For quantity required, see below

GPM	THRUST SPACER	1 HP	1-1/2 HP	2 HP	3 HP	5 HP	7-1/2 HP
35	024883	4	5	7	10	15	22
	134867	N/A	N/A	N/A	N/A	1	1
55	024883	N/A	4	5	7	11	18
	024883	N/A	N/A	4	6	10	15

COMMANDER PRO® SUBMERSIBLE PUMP REPAIR PARTS (For Pricing Refer To Repair Parts Price List)

Commander Pro® 75 Systems						
Description	Qty	CP7507	CP7510	CP7519	CP7527	CP7535
Pump End	1	CP7507RP	CP7510RP	CP7519RP	CP7527RP	CP7535RP
Motor	1	137458	137458	137458	137458	137458
Controller	1	020143	020143	020143	020143	020143
Tank	1	020629	020629	020629	020629	020629
Pressure Sensor Kit*	1	020627	020627	020627	020627	020627
100 Ft. Sensor Lead**	1	020628	020628	020628	020628	020628

* Kit includes pressure sensor, 10 Ft. sensor lead & screwdriver/allen wrench
**Not shown

Commander Pro® 150 Systems							
Description	Qty	CP15010	CP15019	CP15027	CP15035	CP15055	CP15085
Pump End	1	CP15010RP	CP15019RP	CP15027RP	CP15035RP	CP15055RP	CP15085RP
Motor	1	139424	139424	139424	139424	139424	139424
Controller	1	020475	020475	020475	020475	020475	020475
Tank	1	132661	132661	132661	132661	132661	132661
Pressure Sensor Kit*	1	020627	020627	020627	020627	020627	020627
100 Ft. Sensor Lead**	1	020628	020628	020628	020628	020628	020628

* Kit includes pressure sensor, 10 Ft. sensor lead & screwdriver/allen wrench
**Not shown

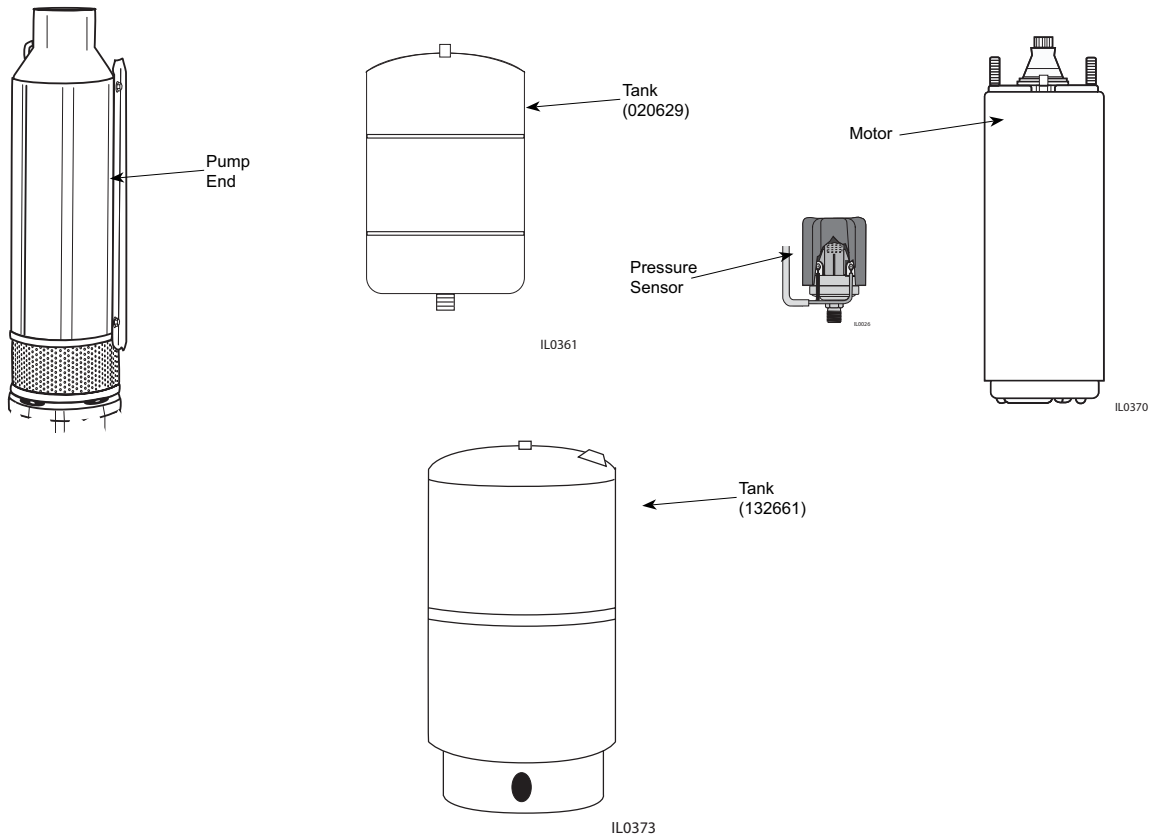

FRANKLIN 1 PHASE CONTROL BOX COMPONENTS (For Pricing Refer To Repair Parts Price List)

CONTROL BOX EQUIPPED WITH BLUE QD RELAY, CAPACITOR — NO OVERLOAD (DATE CODED AFTER JANUARY A94)

		1/3 HP		1/2 HP		3/4 HP	1 HP
		115V	230V	115V	230V	230V	230V
Control Box Numbers	F&W Order No. F.E. No. w/Blue QD Relay	127177 2801024915	127181 2801034915	127185 2801044915	127189 2801054915	127197 2801074915	126319 2801084915
Replacement Voltage Relay Kit	F&W Order No. F.E. No.	137683 305102901	137684 305102902	137683 305102901	137684 305102902	137684 305102902	137684 305102902
Replacement QD Relay Kit	F&W Order No. F.E. No.	137448 305101905	137449 305101901	137450 305101906	137451 305101902	137452 305101903	137453 305901904
Replaces	Relay No.	223415905	223415901	223415906	223415902	223415903	223415904
Replacement Capacitor	F&W Order No. F.E. No.	135553 305207925	135554 305207926	135555 305207951	135556 305207905	135557 305207918	133668 305207913
Replacement Overload Kit	F&W Order No. † F.E. No.	N/A 305100901	137678 305100902	137679 305100903	137680 305100904	137681 305100905	137682 305100906

† Add to control box for pre 1985 motors.

CRC CONTROL BOX EQUIPPED WITH BLUE QD RELAY, RUN CAPACITOR (DATE CODED AFTER JANUARY A94)

		1/2 HP	3/4 HP	1 HP
		230V	230V	230V
Control Box Numbers	F&W Oder No. F.E. No. w/Blue QD Relay	136932 2824055015	136933 2824075015	136934 2824085015
Replacement QD Relay Kit	F&W Order No. F.E. No.	137785 305105901	137786 305105902	137787 305105903
Replaces	F.E. Relay No.	223415912	223415913	223415914
Replacement Start Capacitor	F&W Order No. F.E. No.	135556 305207905	135557 305207918	133668 305207913
Replacement Run Capacitor	F&W Order No. F.E. No.	137687 305203907	137688 305203908	137688 305203908

CRC boxes must be used with motors containing built-in overloads manufactured 1985 or later.

FRANKLIN 1 PHASE CONTROL BOX COMPONENTS (For Pricing Refer To Repair Parts Price List)

1-1/2 — 15HP SINGLE PHASE CONTROL BOX										
MOTOR RATING		CONTROL BOX		CAPACITOR			OVERLOAD		RELAY PART NO. **	CONTACTOR PART NO.
HP	DIA	TYPE	PART NO. *	PART NO. *	TYPE	QTY.	PART NO. *	TYPE		
1-1/2	4"	STD	133589 2823008110	024568	S	1	132390 305215907		137684 305213902	N/R
				127098 305204902	R	1				
2	4"	STD	126321 2823018110	024568	S	1	132390 305215907	S	137684 305213902	N/R
				133669 305204903	R	1	136366 305215913	M		
		DLX	137224 2823018310	024568	S	1	132390 305215907	S	137684 305213902	135270 305226901
				133669 305204903	R	1	136366 305215913	M		
3	4"	STD	126322 2823028110	134310 305206923	S	1	132392 305215908	S	137684 305213902	N/R
				136595 305203909	R	1	136596 305215915	M		
		DLX	136800 2823028310	134310 305206923	S	1	132392 305215908	S	137684 305213902	135270 305226901
				136595 305203909	R	1	136596 305215915	M		
5	4 & 6"	STD	137225 2821138110	136367 305208919	S	1	132391 305215902	S	137684 305213902	N/R
				135268 305203914	R	2	137689 305214902	M		
		DLX	135269 2821139310	136367 305208919	S	1	132391 305215902	S	137684 305213902	135272 305347903
				135268 305203914	R	2	137689 305214902	M		
7-1/2	6"	DLX	135271 2822019310	136367 305208919	S	1	132391 305215902	S	024572 305213961	135272 305347903
				133594 305208918	S	1	136597 305214921	M		
				136595 305203909	R	1				
10	6"	DLX	135273 2822029310	136367 305208919	S	2	137689 305214902	S	024572 305213961	135274 305347902
				133670 305203902	R	2	136364 155409101	M		
15	6"	DLX	136362 2822039310	136367 305208919	S	2	137689 305214902	S	024572 305213961	135274 305347902
				136595 305203909	R	3	136365 155409102	M		
15	6"	DLX	136362 2822039330	020835 305206912	S	3	137689 305214902	S	024572 305213961	136363 305347901
				136365 155409102	R	3	136365 155409102	M		

(*) F&W part number and corresponding Franklin Electric number — Please order by F&W part number.

S = Start; M = Main; R = Run; DLX = Deluxe Control Box w/Contactor

(**) For 208V systems or where line voltage is between 200V and 210V a low voltage relay is required. Use relay part 134141 (305213961) in place of 127102 (315213902) or 136368 (605207913) in place of 134141 (305213961). Use the next larger cable size than specified in 230V table. Order lightning arrester 127103 (150814902) if above ground protection is desired.

CONVERTIBLE and SHALLOW WELL JET PUMP REPAIR PARTS "CPJ" and "CPJS" SERIES (For Pricing Refer To Repair Parts Price List)

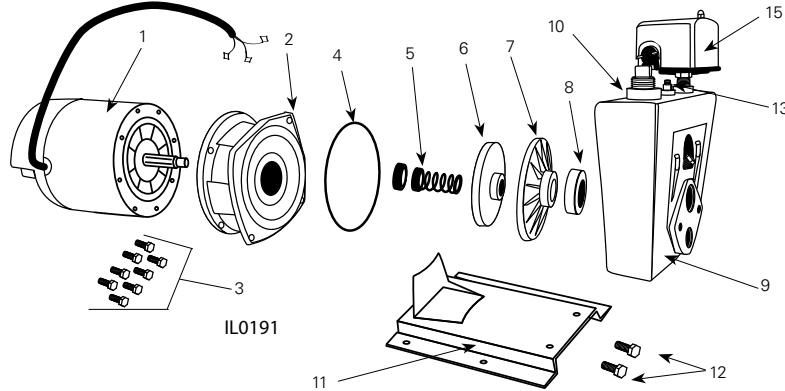

SERVICE KIT FOR JET PUMPS	
MODEL NO	SERVICE KIT FOR:
148143	1/3HP, CPJ Jet Pumps
148141	1/2HP, CPJ & CPH Jet Pumps
148140	3/4HP, CPJ & CPH Jet Pumps
023705	1HP, CPJ & CPH Jet Pumps and VPH10
KIT CONTAINS Impeller, Diffuser, Rotary Seal, Square Cut Ring, Diffuser Rubber	

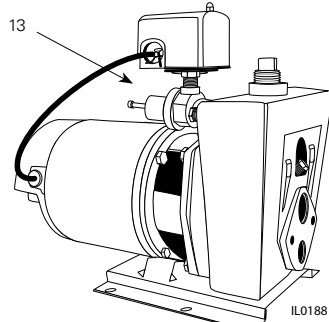

"CPJ" Convertible
3/4 to 1-1/2 HP

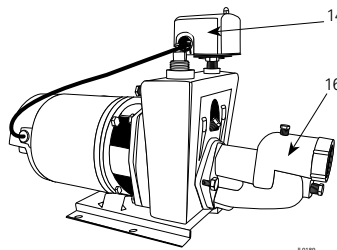

"CPJS" Shallow Well
1/3 to 1/2 HP

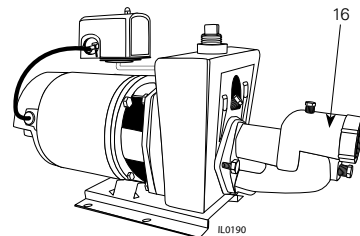

"CPJS" Shallow Well
3/4 to 1-1/2 HP

ITEM	HORSEPOWER	PART NO.	1/3	1/2	3/4	1	1-1/2
	MODEL NO.:"CPJ" Convertible "CPJS" Shallow Well		CPJ03	CPJ05 CPJ05B	CPJ07 CPJ07B	CPJ10 CPJ10B	CPJ15
	DESCRIPTION		CPJ03S CPJ03SB	CPJ05S CPJ05SB	CPJ07S CPJ07SB	CPJ10S CPJ10SB	CPJ15S
QTY							
1	Motor, Nema J (Thd) Motor Cover w/Screws Screws, Cover	021301R 021302	98J103 1	98J105 1	98J107 1	98J110 1	98J115 1
†	Motor Lead Wire		136135A	136135A	136135A	136135A	136136A
2	Mounting Ring	*	135314	135314	136137	136137	136137
3	Hex Hd. Cap Screws 3/8 x 3/4"		8	8	8	8	8
4	Ring, Square Cut	131100	132583	132583	132429	132429	132429
5	Seal, Rotary w/Spring		1	1	1	1	1
6	Impeller		139348††	139349††	134137	134138	132417
7	Diffuser		132424	132424	132425‡	132425‡	132464
8	Rubber, Diffuser	132428	1	1	1	1	1
9	Pump Body		132582	132582	132418	132418	132418
10	Plug, Priming	*	3/4" NPT	3/4" NPT	1" NPT	1" NPT	1" NPT
11	Base	132430A	1	1	1	1	1
12	Hex Hd. Cap Screws 3/8 x 1/2"	*	2	2	2	2	2
13	Control Valve "CPJ"		124330	124330	132446	132446	133383
14	Plug w/Gasket "CPJS"		128794	128794	-	-	-
15	Pressure Switch		132527	132527	132527	132527	132527
16	Shallow Well Ejector Package		SW03E-1626	SW05E-1630	SW07E-1432	SW10E-1334	SW15E-1238
†	Ejector Gasket Pkg. w/Bolts	132404	1	1	1	1	1
†	Ejector Gasket	130969	1	1	1	1	1

- (*) Standard Hardware Item
- (†) Not Shown
- (††) Impeller w/ 138138 Seal Ring
- (‡) Diffuser w/ 134240 Insert

CONVERTIBLE and SHALLOW WELL JET PUMP REPAIR PARTS "CPH" SERIES (For Pricing Refer To Repair Parts Price List)

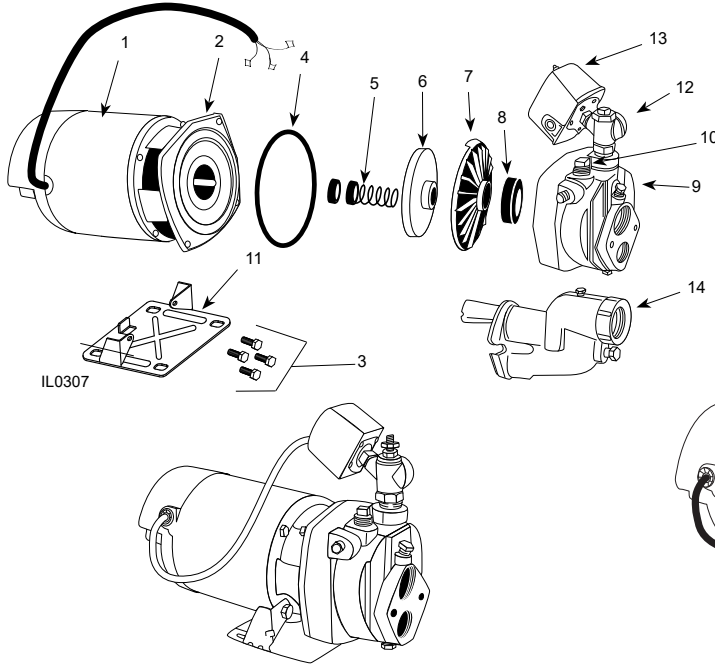

IL0307

IL0345

"CPH" Convertible

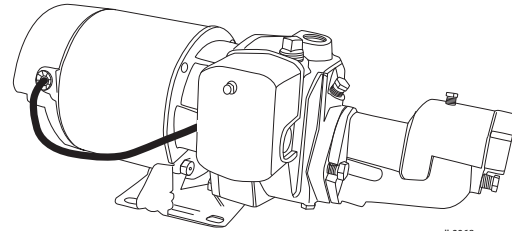

IL0068

"CPHS" Shallow Well

SERVICE KIT FOR JET PUMPS	
MODEL NO	SERVICE KIT FOR:
148143	1/3HP, CPJ & CPH Jet Pumps
148141	1/2HP, CPJ & CPH Jet Pumps
148140	3/4HP, CPJ & CPH Jet Pumps
023705	1HP, CPJ & CPH Jet Pumps and VPH10
KIT CONTAINS Impeller, Diffuser, Rotary Seal, Square Cut Ring, Diffuser Rubber	

ITEM	HORSEPOWER		1/3	1/2	3/4	1
	MODEL NO.: "CPH" Convertible "CPHS" Shallow Well	PART NO.	CPH03	CPH05	CPH07	CPH10
DESCRIPTION		QTY.				
1	Motor, Nema J (Thd) Motor Cover w/screws Screws, Cover † Motor Lead Wire	021301R 021302 136135A	98J103 1 2 1	98J105 1 2 1	98J107 1 2 1	98J110 1 2 1
2	Mounting Ring		135314	135314	136137	136137
3	Hex Hd. Cap Screws 3/8 x 3/4"	*	4	4	4	4
4	Ring, Square Cut		132583	132583	132429	132429
5	Seal, Rotary w/Spring	131100	1	1	1	1
6	Impeller		139348††	139349††	134137	134138
7	Diffuser		132424	132424	132425□	132425□
8	Rubber, Diffuser	132428	1	1	1	1
9	Pump Body		134311	134311	134312	134312
10	Plug, Priming	*	1/2" NPT	1/2" NPT	1/2" NPT	1/2" NPT
11	Base	128034	1	1	1	1
12	Control Assembly "CPH" Convertible Control Body Flow Control Screw	134349 135019 124330	1 1 1	1 1 1	1 1 1	1 1 1
13	Pressure Switch "CPH" Convertible Pressure Switch "CPHS" Shallow Well	132527	1 1	132527 1	132527 1	132527 1
14	Shallow Well Ejector Package-"CPHS" † Ejector Gasket Pkg w/Bolts † Ejector Gasket	132404 130969	SW03E-1626 1 1	SW05E-1630 1 1	SW07E-1432 1 1	SW10E-1334 1 1

(*) Standard hardware item
 (†) Not shown
 (††) Impeller w/ 138138 Seal Ring
 (□) Diffuser w/ 134240 Insert

SHALLOW WELL JET PUMP REPAIR PARTS "E" SERIES (For Pricing Refer To Repair Parts Price List)

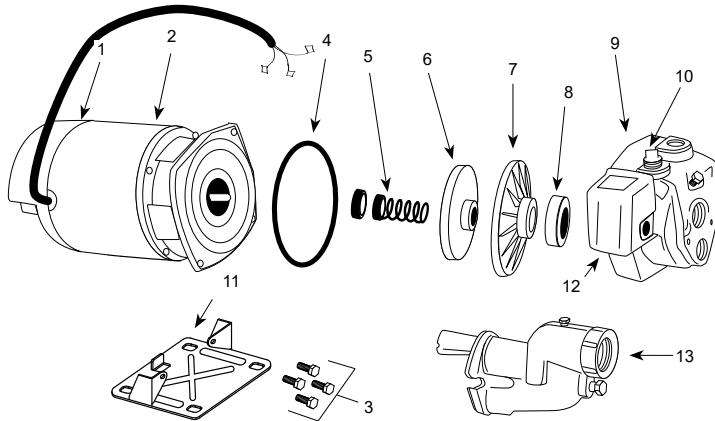

SERVICE KIT FOR JET PUMPS	
MODEL NO	SERVICE KIT FOR:
148143	1/2HP, "E" Series Jet Pumps*
148141	3/4HP, "E" Series Jet Pumps*
148140	1HP, "E" Series Jet Pumps*
KIT CONTAINS Impeller, Diffuser, Rotary Seal, Square Cut Ring, Diffuser Rubber	

ITEM	HORSEPOWER		1/2	3/4	1	1
	MODEL NO.:	PART NO.	EK05	EK07	EK10	EK10S
	DESCRIPTION		QTY.			
1	Motor, Nema J (Thd)		98J105	98J107	98J1071	98J110
	Motor Cover w/Screws	021301R	1	1	1	1
	Screws, Cover	021302	2	2	2	2
	Motor Lead Wire	136135A	1	1	1	1
2	Mounting Ring		135314	135314	136137	135314
3	Hex Hd. Cap Screws 3/8 x 3/4"	*	4	4	4	4
4	Ring, Square Cut		132583	132583	132429	132583
5	Seal, Rotary w/Spring	131100	1	1	1	1
6	Impeller		139348††	139349††	134137	134137
7	Diffuser		132424	132424	132425□	132425□
8	Rubber, Diffuser	132428	1	1	1	1
9	Pump Body		134311	134311	134312	134123
10	Plug, Priming	*	1/2" NPT	1/2" NPT	1/2" NPT	1/2" NPT
11	Base	128034A	1	1	1	1
12	Pressure Switch		020345	020346	020346	020346
13	Ejector Body	135021	1	1	1	1
†	Ejector Gasket Pkg w/Bolts	132404	1	1	1	1
†	Nozzle		4C39-16	4C39-16	4C39-14	4C3914
†	Venturi		4C55-26	4C55-30	4C55-32	4C5532

(*) Standard hardware item
(†) Not shown
(††) Impeller w/ 138138 Seal Ring
(□) Diffuser w/ 134240 Insert

SHALLOW WELL JET PUMP w/INTEGRAL JET REPAIR PARTS "E" SERIES (For Pricing Refer To Repair Parts Price List)

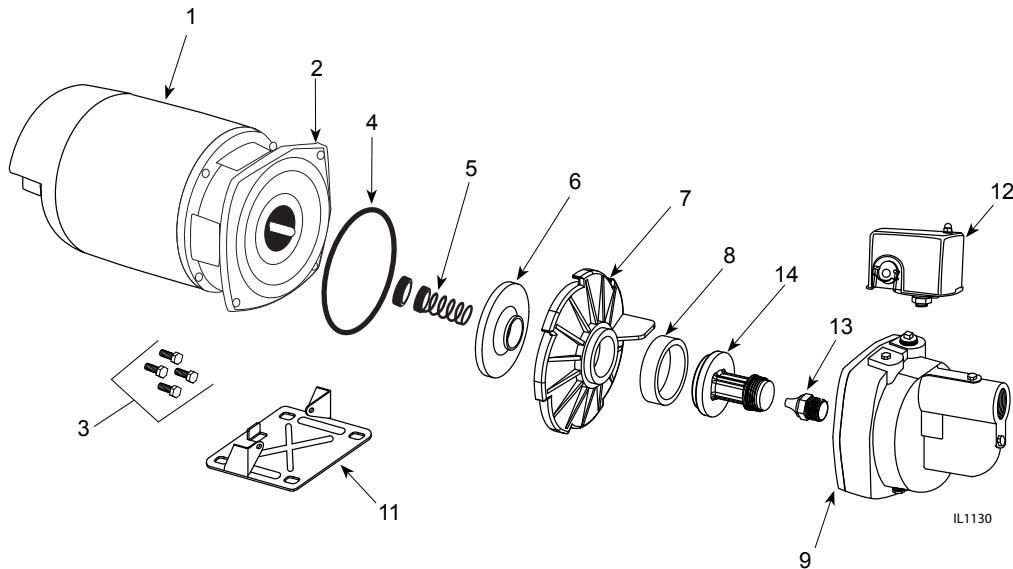

SERVICE KIT FOR JET PUMPS	
MODEL NO	KIT CONTAINS
KH04 ^A	Rotary Seal, Quadraseal (2), Diffuser Rubber

A. Applies to all Horizontal Cast Iron Jet Pumps

ITEM	HORSEPOWER		1/2	3/4
	MODEL NO.:	PART NO.	ES05S/EK05S REV C	ES07S/EK07S REV C
	DESCRIPTION		QTY.	
1	Motor, Nema J (Thd)		98J105	98J107
	Motor Cover w/Screws	021301R	1	1
	Screws, Cover	021302	2	2
	Motor Lead Wire	136135A	1	1
2	Mounting Ring		135314	135314
3	Hex Hd. Cap Screws 3/8 x 3/4"	*	4	4
4	Ring, Square Cut		132583	132583
5	Seal, Rotary w/Spring	131100	1	1
6	Impeller		023502††	139349††
7	Diffuser		132424	132424
8	Rubber, Diffuser	132428	1	1
9	Pump Body	023381	1	1
11	Base	128034A	1	1
12	Pressure Switch - ES Pressure Switch - EK		020345	020345
			020345	020346
13	Nozzle		4C3916	4C3916
14	Venturi		4C6026	4C6032

(*) Standard hardware item
 (†) Not shown
 (††) Impeller w/ 138138 Seal Ring

DEEP WELL JET PUMP REPAIR PARTS “VA”, “VS” & “VPH” SERIES (For Pricing Refer To Repair Parts Price List)

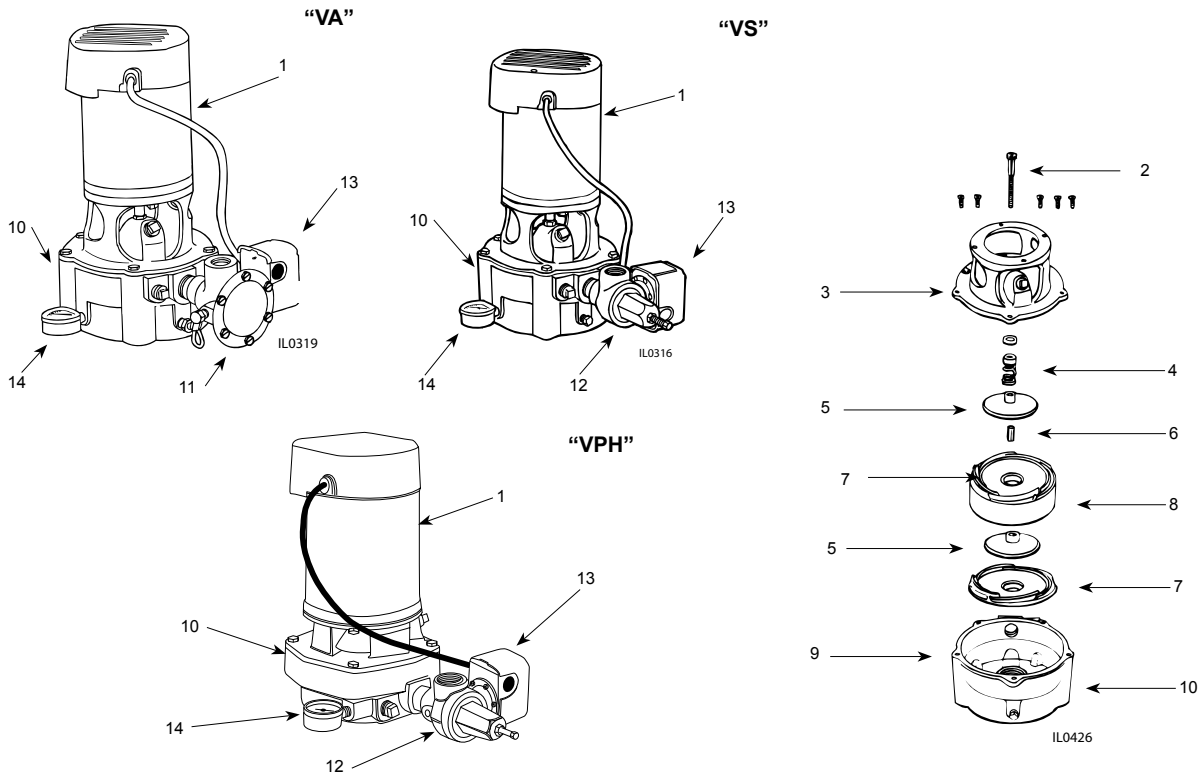

ITEM	DESCRIPTION	HORSEPOWER	1/2	3/4	1	1-1/2	1
		STAGE	1	2	2	2	1
		MODEL NO.	VA105P VS105P	VA207P VS207P	VA210P VS210P	VA215P VS215P	VPH10
		PART NO.	QTY.				
1	Motor, Nema J (Thd)		98H105	98H107	98H110	98H115	98J110
	Motor Cover w/screws	023212	1	1	1	1	1
‡	Screws Cover	021302	2	2	2	2	2
	Motor Lead Wire		136135A	136135A	136135A	136136A	136135A
2	Shaft		135238	135239	135239	135239	N/R
3	Mounting Ring	135235	1	1	1	1	136873
	Hex Hd. Cap Screws 3/8 x 3/4"	*	9	9	9	9	8
4	Seal, Rotary w/Spring	131100	1	1	1	1	1
5	Impeller †		135248	127960	132613	135248	134138
6	Spacer, Shaft	135245	—	1	1	1	—
‡	Spacer, Suction	135243	1	—	—	—	—
7	Diffuser †		135242	135241	135241	135242	132425
8	Intermediate Stage	135246	—	1	1	1	—
‡	Bearing, Intermediate Stage	135247	—	1	1	1	—
9	Ring, Square Cut	135240	1	1	1	1	132429
‡	Rubber, Diffuser	132428	—	—	—	—	1
10	Pump Body	135237	1	1	1	1	134312
11	Control Valve “VA”		C981D	C981G	C981G	C981G	—
12	Control Valve “VS” & “VPH”		132446	133383	133383	133383	132446
13	Pressure Switch	020346	1	1	1	1	1
14	Pressure Gauge	023294	1	1	1	1	1
‡	Plug, Priming 1/2" NPT	*	2	2	2	2	2
‡	Plug, Drain 1/4" NPT	*	1	1	1	1	1

(*) Standard hardware item

(†) For quantity required — See number of stages

(‡) Not shown

NOTE: For horizontal installations, use optional pump base 135276A

AUTOMATIC CONTROL VALVES FOR JET PUMP REPAIR PARTS (For Pricing Refer To Repair Parts Price List)

FORM NO. FW0037
1105
SUPERSEDES 0201
PAGE 3-3A REPAIR PARTS

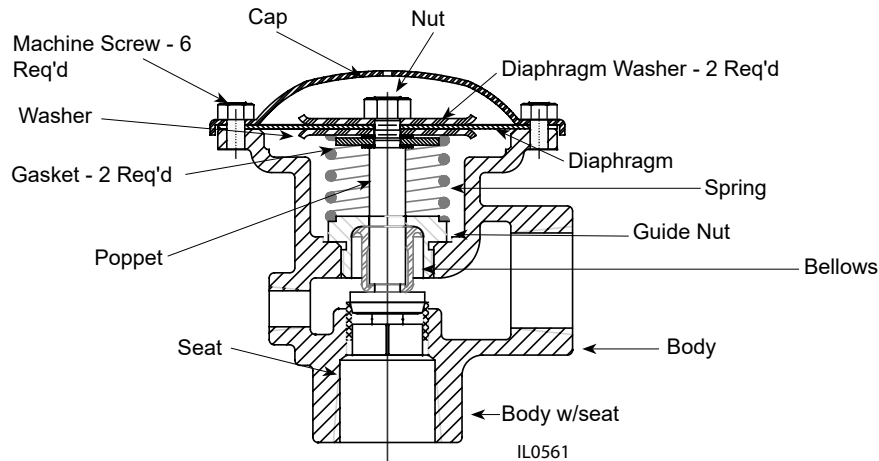

C971, C981 AND C982 SERIES					
MODEL NUMBER	C971A+	C971D+	C971E+	C971F+	C971G+
	C981A	C981D	C981E	C981F	C981G
	C982A+	C982D+	C982E+	C982F+	C982G+
DESCRIPTION	PART NUMBER				
Body with Seat	N/A	N/A	N/A	N/A	N/A
Seat	131324	131324	131324	131324	125207
Spring	126457	131737	131740	131744	131740
Bellows	124581	124581	124581	124581	124581
Gasket 5/16 x 5/8"	131746	131746	131746	131746	131746
Diaphragm	131743	131743	131743	131743	131743
Diaphragm Washer	133680	133680	133680	133680	133680
Repair Kit*	126458	125183	126824	126825	126826
Cap	131741	131741	131741	131741	131741

* Each repair kit contains: Guide nut, Bellows, Poppet, Rubber Seal, Spring, Gasket, Diaphragm, Diaphragm Washer, 1/4" Machine Screws and 5/16" Hex Nut
+ Discontinued

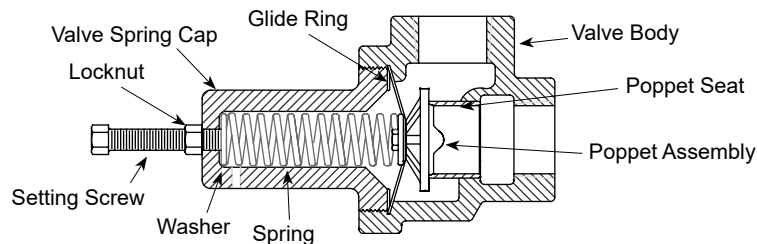

SEMI-AUTOMATIC CONTROL VALVE REPAIR PARTS		
MODEL NUMBER	132446	133383
DESCRIPTION	PART NUMBER	
Valve Body with Seat	N/A	N/A
Poppet Assembly	138175*	138175*
Glide Ring Washer	132442	132442
Spring	132445	133381
Washer for Spring	132444	132444
Setting Screw	132443	132443
Valve Cap	132439	132439

* For valves manufactured after December 1995. Poppet assembly not available for valves manufactured prior to December 1995

FW0038
0914
SUPERSEDES
0910

EJECTOR, WELL ADAPTER & POWER HEAD REPAIR PARTS SHALLOW WELL, CONVERTIBLE & DOUBLE PIPE EJECTORS						
EJECTOR TYPE		SHALLOW WELL	CONVERTIBLE	DOUBLE PIPE DEEP WELL		
MODEL NUMBER		SW-E	DW-E	DP30B	DP35B†	DP40B†
DESCRIPTION	QTY	PART NUMBER				
Body (Only)	1	135021	132433	124771	N/A	N/A
Nozzle *		4C39	4C39	4C39	4C39	4C39
Venturi *		4C55	4C55	4C55	4C55	4C55
Ejector Gasket Package **		132404	132404	132404	132404	132404
Gasket (Only)		130969	130969	130969	130969	130969
Adapter Flange **		N/R	N/R	N/R	N/R	N/A

(*) For correct orifice size -- See jet pump selection charts in general catalog

(**) Includes gasket and cap screws

(N/R) Not Required

(N/A) Not Available

(†) Discontinued

SINGLE PIPE "PACKER" EJECTORS							
EJECTOR TYPE		RUBBER PACKER	LEATHER PACKER				
MODEL NUMBER		SP20BR	SP20BL	SP20CL	SP22CL	SP25BL†	SP30BL†
DESCRIPTION	QTY	PART NUMBER					
Ejector Assembly *	1	N/A	132680	N/A	133374	N/A	N/A
Body with Screen	1	N/A	127408	N/A	133375	N/A	N/A
Nozzle **	1	4C39	4C39	4C39	4C39	4C39	4C39
Venturi **	1	4C55	4C55	4C55	4C55	4C55	4C55
Dog Spring Coupling	1	N/A	N/R	N/R	N/R	N/R	N/R
Spacer	1	N/R	124036	124036	124036	N/A	N/A
Packer (Rubber)	1	N/A	N/R	N/R	N/R	N/R	N/R
Packer (Leather)	2	N/R	124038	124038	124038	N/A	N/A
Washer (Brass Ring)	1	N/A	127944	127944	127944	N/A	N/A

(*) Less nozzle and venturi

(**) For correct orifice size -- See Jet Pump Selection charts in general catalog

(N/R) Not Required

(†) Discontinued models

WELL ADAPTERS - STRAIGHT AND RIGHT ANGLE							
WELL SIZE I.D.		2"	2"	2-1/2"	3"	3"	
DRIVE PIPE		1"	1"	1"	1"	1"	
SUCTION PIPE		1-1/4"	1-1/4"	1-1/4"	1-1/4"	1-1/4"	
DROP PIPE		1"	1-1/4"	1-1/4"	1-1/2"	1-1/4"	
STRAIGHT ADAPTER		129719*	129720*	129725†	129727†	129728†	
RIGHT ANGLE ADAPTER		127025*	129723*	N/A	127949†	N/A	
DESCRIPTION	QTY	PART NUMBER					
Body	1	N/A	N/A	N/A	N/A	N/A	
Lower Packer Rubber	1	131975	131975	N/A	N/A	N/A	
Lower Gland Flange	1	131219	131219	N/A	N/A	N/A	
Ejector Gasket Package	1	132404	132404	132404	132404	132404	
Gasket (Only)	1	130969	130969	130969	130969	130969	
Machine Bolt w/Nut‡	3	3/8 x 2-1/2"	3/8 x 2-1/2"	7/16 x 3-1/2"	7/16 x 3-1/2"	7/16 x 3-1/2"	

(*) Includes all parts listed

(†) Discontinued Models

(‡) Standard hardware item

(N/A) Not available

POWER HEAD CONVERSION UNIT REPAIR PARTS			
DESCRIPTION	122649		135458
	PART NUMBER		
Ball Bearing (1.57 O.D.)	022962		022962
Ball Bearing (1.85 O.D.)	121777		121777
Shaft	122530		135457
Bearing Retainer	121758		121758
Retaining Ring	122478		122478 (2)

CENTRIFUGAL PUMP REPAIR PARTS CJ103 SERIES (For Pricing Refer To Repair Parts Price List)

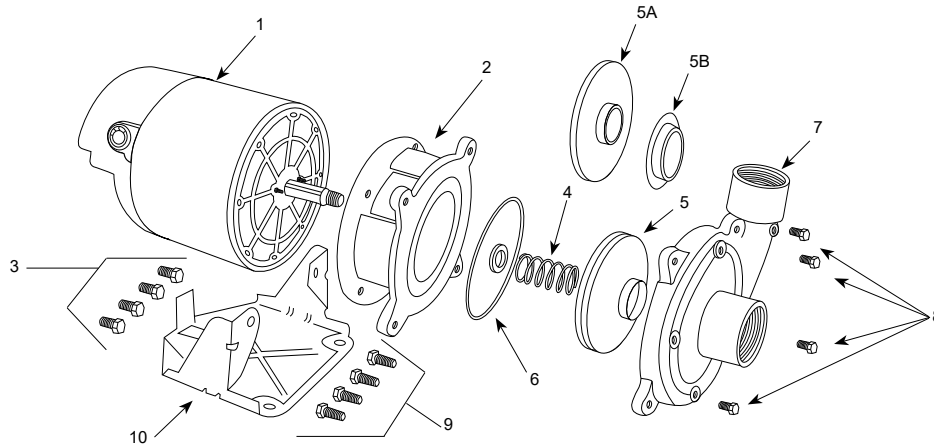

		HP	1/3	1/2	3/4	1	1-1/2	3**
		STAGE	1	1	1	1	1	1
ITEM	SINGLE PHASE BRASS IMPELLER	MODEL NO.	CJ103031	CJ103051	CJ103071	CJ103101	CJ103151	CJ103201
	THREE PHASE BRASS IMPELLER			CJ103053	CJ103073			
	SINGLE PHASE PLASTIC IMPELLER		CJ103P031	CJ103P051	CJ103P071	CJ103P101	CJ103P151	CJ103P201
	THREE PHASE PLASTIC IMPELLER			CJ103P053	CJ103P073			
	DESCRIPTION	PART NO.	QTY.					
1	Motor, Nema J - 1PH Feb 1, 2020 and later		98J103	98J105	98J107	98J610***	98J615***	98J630***
1	Motor, Nema J - 1PH Jan 30, 2020 and earlier		98J103	98J105	98J107	98J110	98J115	98J120
1	Motor, Nema J - 3PH		—	98J305	98J307	98J310	98J315	98J320
	Motor Access Cover	021301R	1	1	1	1	1	1
	Screws, Access Cover	021302	2	2	2	2	2	2
‡	Slinger Washer	126905	1	1	1	1	1	1
2	Mounting Ring	134107	1	1	1	1	1	1
3	Hex Hd. Cap Screws 3/8 x 3/4"	*	4	4	4	4	4	4
4	Seal, Rotary w/Spring	131100	1	1	1	1	1	1
5	Impeller - Brass	130403	126900	127805	127804	127806	127848	
5A	Impeller - Plastic	133426	139222	021280	135248	021279	N/A	
5B	Clearance Ring	N/A	138138	134240	134240	134240	N/A	
6	Ring, Square Cut †	132583	1	1	1	1	1	1
7	Body Assembly - Brass Impeller		127870	127870	127780	127780	127780	127780
	Body Assembly - Plastic Impeller	021439	1	1	1	1	1	N/A
‡	Suction Clearance Ring-Brass		127869A	127869A	N/A	N/A	N/A	N/A
8	Pipe Plugs, 1/8" NPT	*	4	4	4	4	4	4
9	Hex Hd. Cap Screws 3/8 x 1"	*	4	4	4	4	4	4
10	Base	125855	1	1	1	1	1	1

(*) Standard hardware item

(‡) Not shown

(†) For pumps with paper gasket, replace with part number 127782

(Δ) Kit Includes: Access Cover, Screws & Wiring Diagrams

(**) 2HP Jan 30, 2020 and earlier

(***) 230V only

CENTRIFUGAL PUMP REPAIR PARTS CJ101 SERIES (For Pricing Refer To Repair Parts Price List)

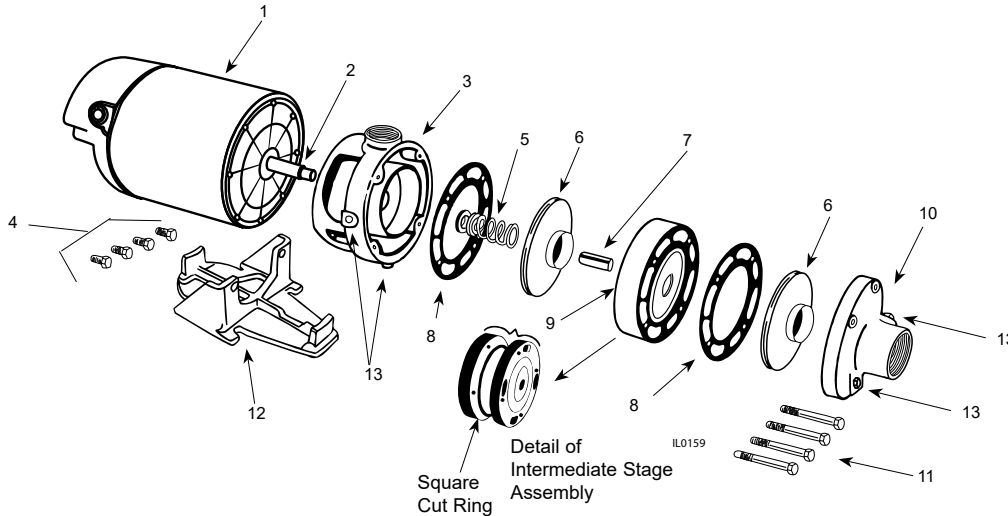

		HP	3/4	1	1-1/2	2	2	3
		STAGE	2	2	2	2	3	3
ITEM	SINGLE PHASE - BRASS IMPELLER	MODEL NO.	CJ101B071	CJ101B101	CJ101B151	CJ101B201	CJ101C201	CJ101C301
	THREE PHASE - BRASS IMPELLER		CJ101B073	CJ101B103	CJ101B153	CJ101B203	CJ101C203	CJ101C303
	SINGLE PHASE - PLASTIC IMPELLER		CJ101P071	CJ101P101	CJ101P151	CJ101P201	CJ101D201	CJ101D301
	THREE PHASE - PLASTIC IMPELLER		CJ101P073	CJ101P103	CJ101P153	CJ101P203	CJ101D203	CJ101D303
DESCRIPTION		PART NO.	QTY					
1	Motor, Nema J - 1 PH		98J107	98J110	98J115	98J120	98J120	98J630
1	Motor, Nema J - 3 PH		98J307	98J310	98J315	98J320	98J320	023251
	Motor Cover w/Screws	021301R	1	1	1	1	1	1
	Screws, Cover	021302	2	2	2	2	2	2
‡	Slinger Washer	126905	1	1	1	1	1	1
2	Shaft	135279A	135279A	135279A	135279A	135279A	136612A	136612A
3	Mounting Ring	125204	1	1	1	1	1	1
4	Hex Hd. Cap Screws 3/8 x 3/4"	*	2	2	2	2	2	2
5	Seal, Rotary w/Spring	131100	1	1	1	1	1	1
6	Impeller, Brass		†135280	†135281	†126900	†126901	†139126	†136951
6	Impeller, Thermoplastic		†133425	†133427	†139180	†128472	†139348***	†139104
7	Spacer, Shaft	133380	1	1	1	1	2	2
8	Gasket	130968	2	2	2	2	3	3
9	Intermediate Stage Assy-Brass**	131239B	1	1	1	1	2	2
9	Intermediate Stage Assy-Plastic**	023405	1	1	1	1	2	2
‡	Suction Clearance Ring	130957	1	1	1	1	2	2
‡	Hub Clearance Ring	131282	1	1	1	1	2	2
‡	Square Cut Ring Interm. Stg.	020240	1	1	1	1	2	2
10	Suction Flange Assembly-Brass	125227A	1	1	1	1	1	1
10	Suction Flange Assembly-Plastic	023404	1	1	1	1	1	1
‡	Suction Clearance Ring	130957	1	1	1	1	1	1
‡	Suction Bearing	020053	1	1	1	1	1	1
11	Pump thru Bolts (Grade 5) 3/8" x 3-1/4"	*	4	4	4	4	--	--
11	Pump thru Bolts (Grade 5) 3/8" x 5"		--	--	--	--	4	4
12	Base w/ Bolts 3/8" x 1-1/4"	020054	1	1	1	1	1	1
13	1/4" NPT Plug	*	4	4	4	4	4	4

(*) Standard hardware item

(†) For quantity required — See number of stages

(‡) Not shown

(**) Includes two castings, square cut ring, suction and hub clearance ring - See Detail Drawing

(***) Includes 138138 seal ring and 139221 impeller

(Δ) Kit Includes: Access Cover, Screws & Wiring Diagrams

SELF-PRIMER PUMP REPAIR PARTS “SPJ/ELJ” SERIES (For Pricing Refer To Repair Parts Price List)

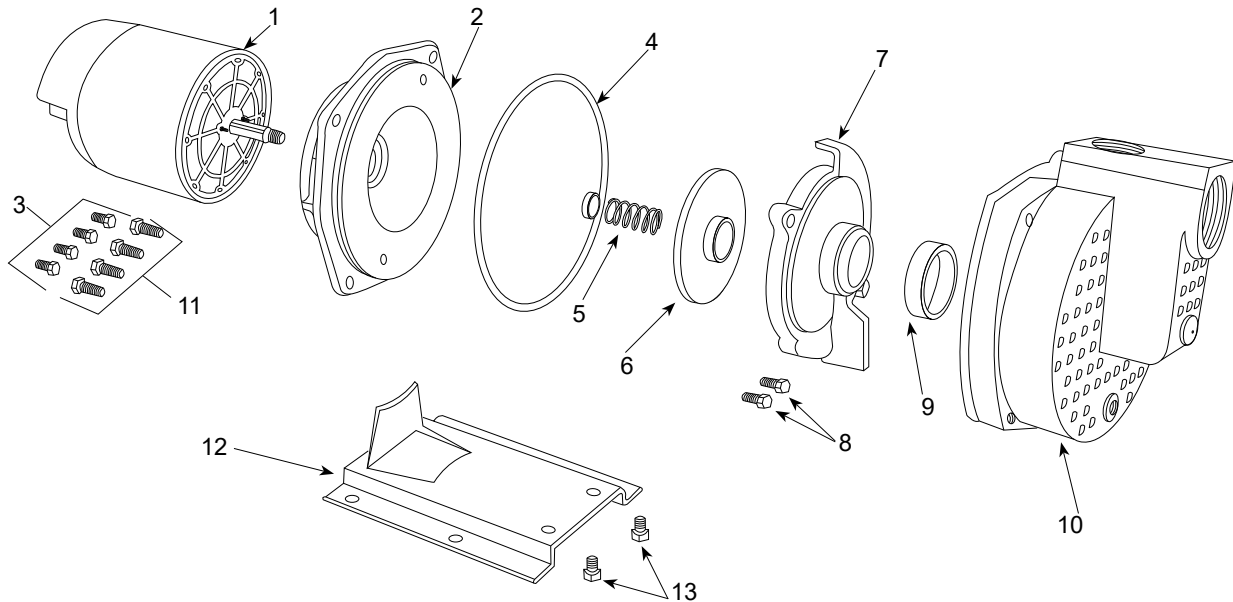

		HORSEPOWER	3/4	1	1-1/2	2	3
ITEM	SINGLE PHASE	MODEL NO.			SPJ15P1		
			SPJ07P1	SPJ10P1	SPJ15B1 ELJ15B1	SPJ20B1 ELJ20B1	SPJ30B1 ELJ30B1
	THREE PHASE		SPJ07P3	SPJ10P3	SPJ15B3	SPJ20B3	SPJ30B3
	DESCRIPTION	PART NO.	QTY				
1	Motor, Nema J - 1 PH		98J107	98J110	98J115	98J120	98J630
1	Motor, Nema J - 3 PH		98J307	98J310	98J315	98J320	023251
‡	Motor Cover w/Screws Screws, Cover	021301R 021302	1	1	1	1	1
‡	Slinger, Washer	126905	1	1	1	1	1
2	Mounting Ring	133904	1	1	1	1	1
3	Hex Hd. Cap Screws 3/8 x 3/4"	*	4	4	4	4	4
4	Ring, Square Cut	133261	1	1	1	1	1
5	Seal, Rotary w/Spring	131100	1	1	1	1	1
6	Impeller, Plastic "P" Models		133646	135620	134138	—	—
6	Impeller, Brass "B" Models		—	—	133253	133255	138056
7	Diffuser w/ Insert	136469†	1	1	1	1	1
8	Hex Hd. Cap Screws 1/4 x 1"	*	2	2	2	2	2
9	Rubber Diffuser	133260	1	1	1	1	1
10	Pump Body	133362	1	1	1	1	1
11	Hex Hd. Cap Screws 7/16 x 1"	*	4	4	4	4	4
12	Base	134217A	1	1	1	1	1
13	Hex Hd. Cap Screws 3/8 x 1/2"	*	2	2	2	2	1

(*) Standard hardware item
 (‡) Not shown
 (†) Diffuser w/ 134240 Insert

SELF-PRIMER PUMP REPAIR PARTS "SP/EL" SERIES (For Pricing Refer To Repair Parts Price List)

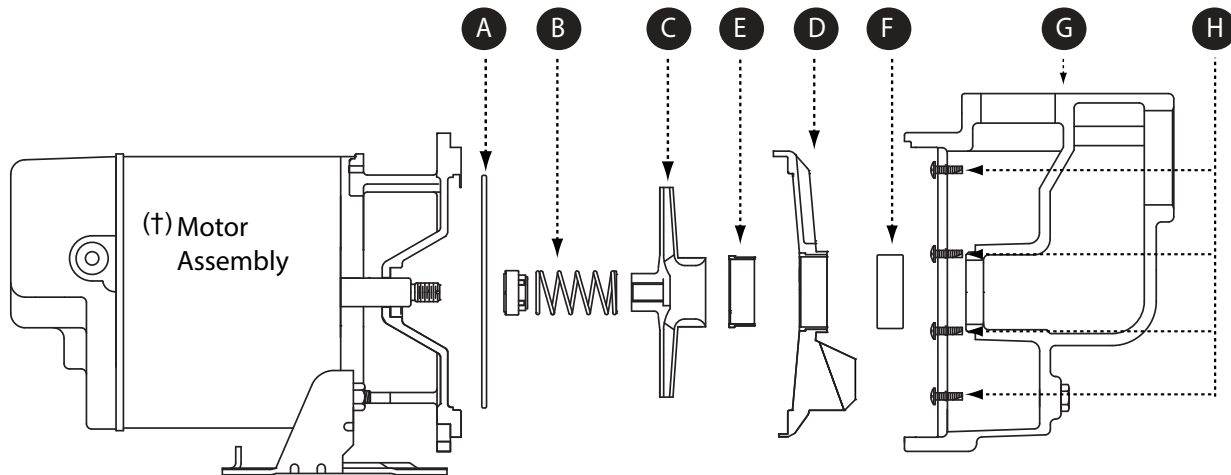

		HP	1	1-1/2	2
ITEM	SINGLE PHASE	MODEL NO.	SP10P1 EL10P1	SP15P1 EL15P1	SP20P1 EL20P1
	DESCRIPTION	PART NO.			
A	Ring, Square Cut	132429	1	1	1
B	Seal, Rotary and Ceramic (with Spring)	131100	1	1	1
C	Impeller		021280	134138	134138
D	Diffuser	132425	1	1	1
E	Diffuser Insert	134240	1	1	1
F	Rubber Diffuser	132428	1	1	1
G	Pump Body	023115	1	1	1
H*	Hex Hd. Cap Screws 3/8 in. x 3/4 in.	*	4	4	4

(*) Standard hardware item
(†) Motor assembly not available as a replacement part.

SPM SERIES HIGH POWER CENTRIFUGALS (For Pricing Refer To Repair Parts Price List)

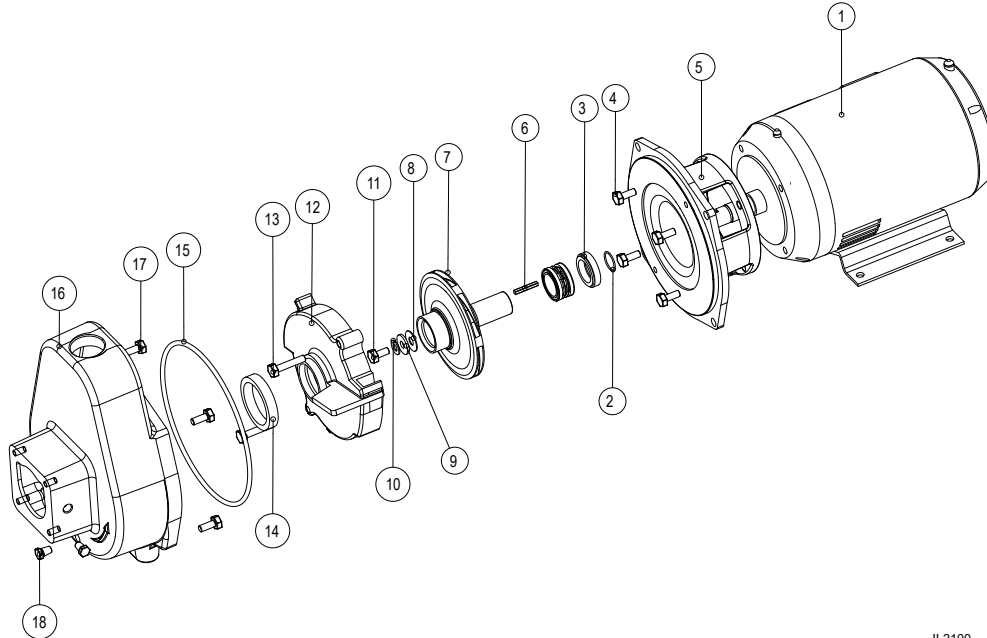

IL2100

ITEM	DESCRIPTION	QTY	3 HP 1 PH	3 HP 3 PH	5 HP 1 PH	5 HP 3 PH
			PART #	PART #	PART #	PART #
1	BALDOR MOTOR	1	134962	134965	134963	134966
2	O-RING, 1.00 x .07" THICKNESS	1	024893	024893	024893	024893
3	MECHANICAL SEAL, JOHN CRANE TYPE 2100, 1.25"	1	024901	024901	024901	024901
4	CAP SCREW, 3/8-16 x .875" LONG	4	*	*	*	*
5	MOUNTING RING	1	024898	024898	024898	024898
6	KEY BALDOR	1	025247	025247	025247	025247
7	IMPELLER	1	025245	025245	025246	025246
8	GASKET, OD 1.15", ID.45" x .03" THICKNESS	1	025501	025501	025501	025501
9	WASHER, OD1.125", ID.415" x .125" THICKNESS	1	024905	024905	024905	024905
10	GASKET, OD.66", ID.35" x .05" THICKNESS	1	025502	025502	025502	025502
11	CAP SCREW, 3/8-16 x .75" LONG	1	*	*	*	*
12	DIFFUSER w/WEAR RING	1	024908	024908	024908	024908
13	CAP SCREW, 3-16 x 1.75" LONG	2	*	*	*	*
14	DIFFUSER RING GASKET, OD 3.0", ID2.4" x .53" THICKNESS	1	024909	024909	024909	024909
15	GASKET, 8.84" X 0.23" THICKNESS	1	024899	024899	024899	024899
16	PUMP BODY	1	024910	024910	024911	024911
17	CAP SCREW, 3/8-16 x .875" LONG	4	*	*	*	*
18	PIPE PLUG, 1/4" NPT	2	024593	024593	024593	024593
order from catalog	SUCTION FLANGE KIT	1	024912	024912	024913	024913

CENTRIFUGAL PUMP REPAIR PARTS "C22000" SERIES (For Pricing Refer To Repair Parts Price List)

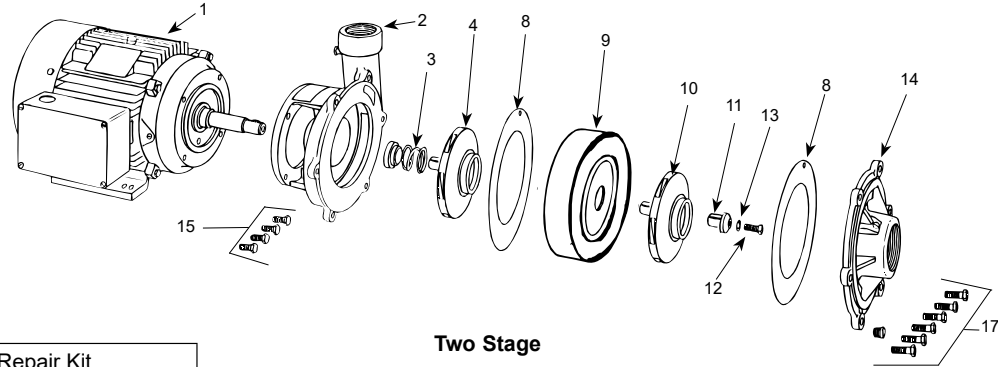

Two Stage

Product may not be exactly as shown.

021434 Repair Kit Kit Includes:		
Qty.	Item No.	Part No. & Description
1	3	136559 Seal Assembly
1	•	136576 O-Ring, Cap Screw
1	•	136572 O-Ring, Impeller
1	•	136569 O-Ring, Impeller
2	8	124638 Gasket

ITEM	HORSEPOWER	3	5	7-1/2
		STAGE	2	2
	SINGLE PHASE	C22231	C22251	—
	THREE PHASE	C22233	C22253	C22273
DESCRIPTION		PART NUMBER		
1	Motor — 1 Phase	134962	134963	—
1	Motor — 3 Phase	134965	134966	134967
2	Mounting Ring	136556	136556	136556
3	Seal Assembly	136559	136559	136559
	• Key 3/16 x 27/32"	—	—	—
	• Key 3/16 x 2-1/32"	134977	134977	134977
4	Impeller	136563	136565	136567
	• O-Ring, Impeller	136569	136569	136569
5	Retainer, Impeller	—	—	—
6	Cap Screw 1" Long	—	—	—
	• O-Ring, Cap Screw	—	—	—
7	Lock Washer 3/8" S.S.	—	—	—
8	Gasket	124638 (2)	124638 (2)	124638 (2)
9	Intermediate Stage w/Clearance Ring	136578	136578	136578
	• Clearance Ring - Large	125176	125176	125176
	• Clearance Ring - Small	136577	136577	136577
10	Impeller (Front)	136564	136566	136568
11	Retainer, Impeller	136571	136571	136571
	• O-Ring, Impeller	136572	136572	136572
12	Cap Screws 2-1/4" Long	136575	136575	136575
	• O-Ring, Cap Screw	136576	136576	136576
13	Lock Washer 3/8" S.S.	120649	120649	120649
14	Suction Flange Assembly w/Clearance Ring	023089	023089	023089
	• Clearance Ring	125176	125176	125176
	• Pipe Plug 1/4" NPT	* (5)	* (5)	* (5)
15	Hex Hd. Cap Screws 3/8 x 1"	* (4)	* (4)	* (4)
16	Hex Hd. Cap Screws 3/8 x 1-1/4"	—	—	—
17	Hex Hd. Cap Screws 3/8 x 3-1/4"	* (6)	* (6)	* (6)

(*) Standard hardware item

(*) Not shown

PRESSURE BOOSTER PUMP REPAIR PARTS (For Pricing Refer To Repair Parts Price List) Replacement Motors

FORM NO. FW0045
1021
SUPERSEDES
1020

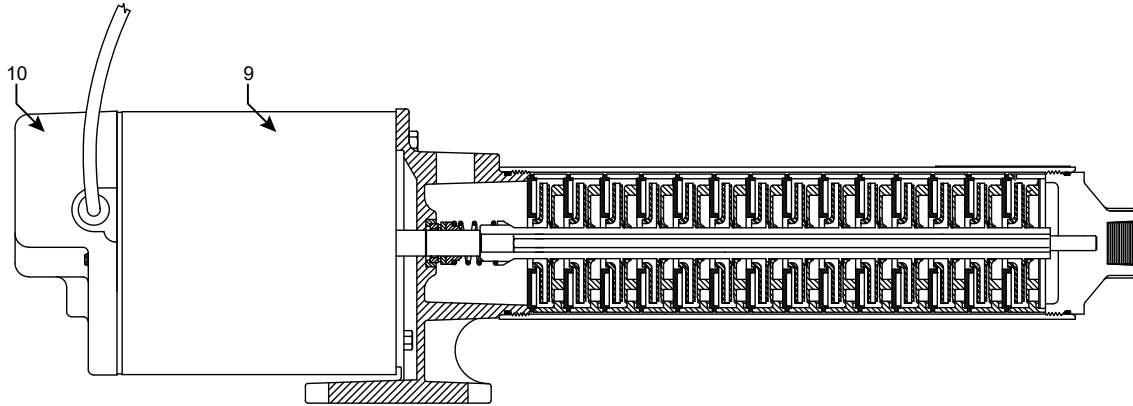

ITEM	REPLACEMENT MOTORS	QTY	CAST IRON	POWDER COATED	STAINLESS STEEL	CAST IRON	POWDER COATED	STAINLESS STEEL
			SINGLE PHASE 60 HZ			THREE PHASE 60 HZ		
9	ODP NEMA J 1/3 HP	1	98J103	98J103	98S103			
	ODP NEMA J 1/2 HP		98J105	98J105	98S105	98J305	98J305	98S305
	ODP NEMA J 3/4 HP		98J107	98J107	98S107	98J307	98J307	98S307
	ODP NEMA J 1 HP		98J110	98J110	98S110	98J310	98J310	98S310
	ODP NEMA J 1-1/2 HP		98J115	98J115	98S115	98J315	98J315	98S315
	ODP NEMA J 2 HP		98J120	98J120	98S120	98J320	98J320	98S320
	ODP NEMA J 3 HP		98J630	98J630	98S630	N/A	N/A	N/A
10	Motor Cover w/Screws	1	023212	023212	023212	023212	023212	023212
*	Screws, Motor Cover	2	021302	021302	021302	021302	021302	021302
			SINGLE PHASE 50 HZ			THREE PHASE 60/50 HZ		
9	ODP NEMA J 1/3 HP	1	98J003	98J003	98S003			
	ODP NEMA J 1/2 HP		98J005	98J005	98S005	98J305	98J305	98S305
	ODP NEMA J 3/4 HP		98J007	98J007	98S007	98J307	98J307	98S307
	ODP NEMA J 1 HP		98J010	98J010	98S010	98J310	98J310	98S310
	ODP NEMA J 1-1/2 HP		98J015	98J015	98S015	98J315	98J315	98S315
	ODP NEMA J 2 HP		98J820	98J820	98S820	98J320	98J320	98S320
10	Motor Cover w/Screws	1	023212	023212	023212	023212	023212	023212
*	Screws, Motor Cover	2	021302	021302	021302	021302	021302	021302
			SINGLE PHASE 60/50 HZ			THREE PHASE 60/50 HZ		
9	TEFC NEMA J 1/2 HP	1		020691	020691		021011	021011
	TEFC NEMA J 3/4 HP			021008	021008		021012	021012
	TEFC NEMA J 1 HP			021009	021009		020688	020688
	TEFC NEMA J 1-1/2 HP			020692	020692		020647	020647
	TEFC NEMA J 2 HP			020693	020693		020689	020689
	TEFC NEMA J 3 HP			021010	021010		025585	025585

* Not Shown

N/A - Not available

FORM NO. FW0046
1021
SUPERSEDES
1020

PRESSURE BOOSTER PUMP REPAIR PARTS (For Pricing Refer To Repair Parts Price List)

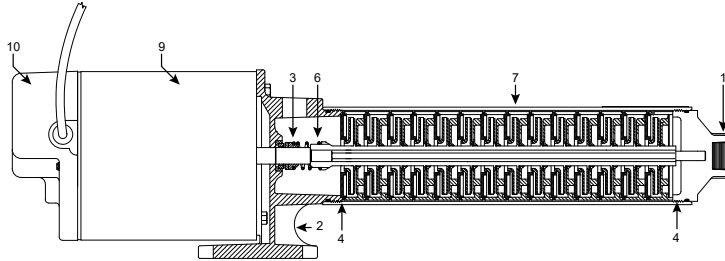

	ITEM	DESCRIPTION	QTY	CAST IRON	POWDER COATED	STAINLESS STEEL	
5 - 7 - 10 - 19 GPM, 60 HZ & 50 HZ	1	Discharge Head 3/4" NPT	1	132000	136905	136640	See replacement motors. ITEMS 9 & 10
	2	Mounting Ring 3/4" NPT	1	132002	136904	136639	
27 - 35 GPM, 60 HZ & 50 HZ	1	Discharge Head 1" NPT	1	136635	137796	139166	
	2	Mounting Ring 1" NPT	1	136634	137794	139100	
55 - 85 GPM, 60 HZ & 50 HZ	1	Discharge Head 2" NPT	1	021585	-	-	
	2	Mounting Ring 2" NPT	1	021584	-	-	
ALL SERIES 60 HZ & 50 HZ	3	Seal, Rotary w/Spring	1	131100 †	131100 †	136682 ‡	
	4	O-Ring	2	131925 ■	131925 ■	136607 ▲	
	*	Hex Head Cap Screws 3/8" x 3/4"	4	121106	121106	121106	

(†) Buna N - Carbon/Silicon Carbide (‡) Viton - Carbon/Silicon Carbide (■) Buna N (▲) Viton (*) Not Shown

60 HZ MODELS	MATERIAL	CAST IRON	PB0508AXXX	PB0512AXXX	PB0516AXXX	PB0712AXXX	PB1014AXXX	PB1016AXXX
		POWDER COATED	PB0508CXXX	PB0512CXXX	PB0516CXXX	PB0712AXXX	PB1014CXXX	PB1016CXXX
		STAINLESS STEEL	PB0508SXXX	PB0512SXXX	PB0516SXXX	PB0712SXXX	PB1014SXXX	PB1016SXXX
ITEM	DESCRIPTION	PART NUMBER						
5	Cartridge Assembly ‡	135163	132939	138447	134097	134998	135814	
6	Shaft & Coupling Assembly	135161	133336	138446	133336	134996	135813	
7	Barrel/Shell	135162	132003	138448	132003	134997	135815	
MATERIAL	CAST IRON	PB1914AXXX	PB2711AXXX	PB2714AXXX		PB3506AXXX	PB3508AXXX	
	POWDER COATED	PB1914CXXX	PB2711CXXX	PB2714CXXX		PB3506CXXX	PB3508CXXX	
	STAINLESS STEEL	PB1914SXXX	PB2711SXXX	PB2714SXXX	PB2717SXXX	PB3506SXXX	PB3508SXXX	
ITEM	DESCRIPTION	PART NUMBER						
5	Cartridge Assembly ‡	137222	135627	136629	020980	136626	136632	
6	Shaft & Coupling Assembly	137221	136624	136628	020916	136625	136631	
7	Barrel/Shell	137223	135628	136630	138947	136627	136633	
MATERIAL	CAST IRON	PB5504XX	PB5506XX	PB8504XX	PB8505XX			
ITEM	DESCRIPTION	PART NUMBER						
5	Cartridge Assembly ‡	022293	022294	022295	022296			
6	Shaft & Coupling Assembly	022289	022287	022288	022287			
7	Barrel/Shell	022291	022292	138151	022290			

50 HZ MODELS	MATERIAL	CAST IRON	PB0508XXX	PB0514XXX	PB0714XXX	PB1020XXX	PB1022XXX	PB1023XXX
		POWDER COATED	PB0508ZXXX	PB0514ZXXX	PB0714ZXXX	PB1020ZXXX	PB1022ZXXX	PB1023ZXXX
		STAINLESS STEEL	PB0508YXXX	PB0514YXXX	PB0714YXXX	PB1020YXXX	PB1022YXXX	PB1023YXXX
ITEM	DESCRIPTION	PART NUMBER						
5	Cartridge Assembly ‡	135163	138150	021032	135907	020280	135911	
6	Shaft & Coupling Assembly	135161	138149	138149	135906	020278	135910	
7	Barrel	135162	138151	138151	135098	020094	135912	
MATERIAL	CAST IRON	PB1920XXX		PB2717XXX	PB3508XXX	PB3514XXX		
	POWDER COATED	PB1920ZXXX	PB1922ZXXX	PB2717ZXXX	PB3508ZXXX	PB3514ZXXX		
	STAINLESS STEEL	PB1920YXXX		PB2717YXXX	PB3508YXXX	PB3514YXXX		
ITEM	DESCRIPTION	PART NUMBER						
5	Cartridge Assembly ‡	020982	139435	020980	136632	021017		
6	Shaft & Coupling Assembly	020093	021425	020916	136631	021015		
7	Barrel	020094	139436	138947	136633	021016		

(‡) Cartridge assembly includes: impellers, diffusers, o-rings and shaft & coupling assembly. Components not available individually. Sold as assembly only.

COLUMN SUMP PUMP REPAIR PARTS (For Pricing Refer To Repair Parts Price List)

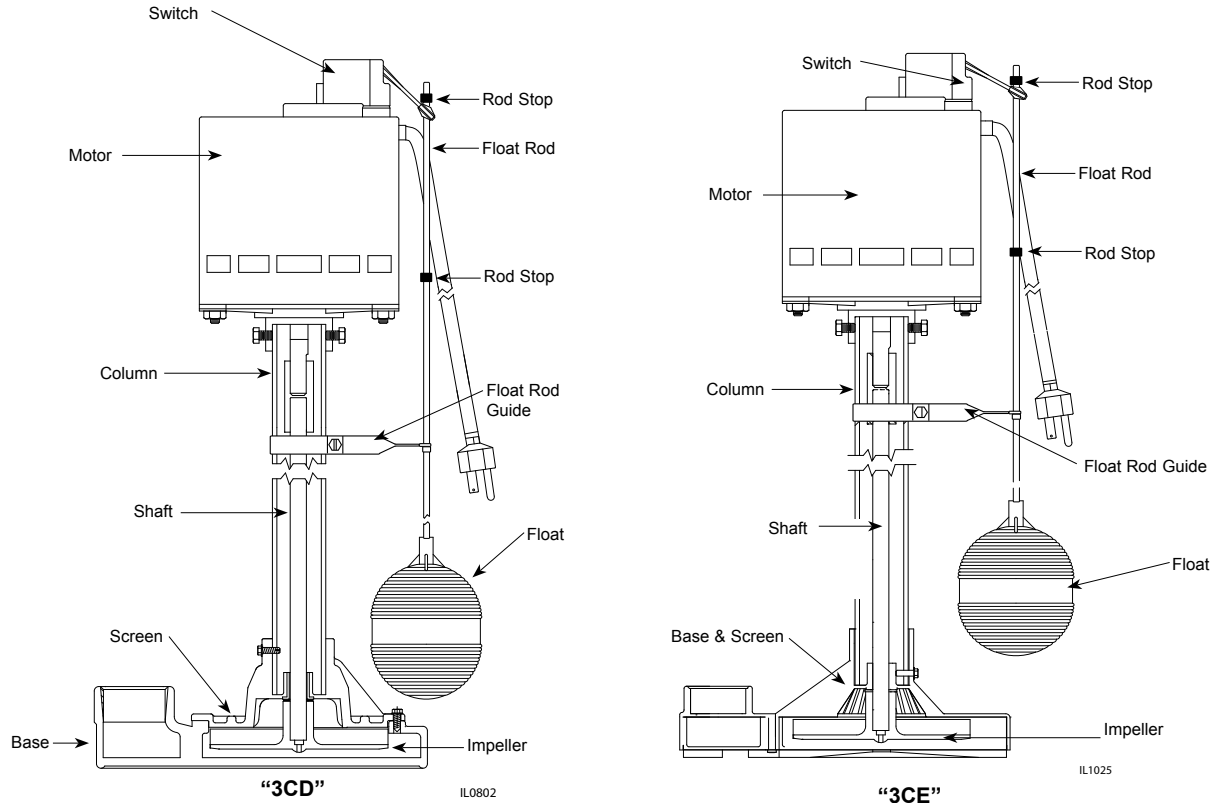

MODEL NO.	DATE CODE					
	BEFORE 95-03 (3/95)		95-03 THRU 01-10		AFTER 01-11	
	3CD	3CE	3CD	3CE	3CD	3CE
DESCRIPTION	PART NUMBER					
Base	132139	132139 †	132139	N/R	132139	N/R
Screen	N/A	N/A	130503	N/R	130503	N/R
Base & Screen	N/R	N/R	N/R	N/A	N/R	N/A
Column	N/A	N/A	128319	128319	128319	128319
Machine Screw 1/4" - 20 x 1/2"	* (2)	* (2)	* (2)	* (2)	* (2)	* (2)
Washer/Thrust	N/A	N/A	N/R	N/R	139496	139496
Shaft	N/A	N/A	N/A	N/A	138970	138970
Impeller	132073	132073	N/A	N/A	132073	132073
Float Rod Guide w/Screw	132012	132012	132012	132012	132012	132012
Float Rod w/Stops	135267	135267	135267	135267	135267	135267
Rod Stops (2)	135266	135266	135266	135266	135266	135266
Float	001134	001134	001134	001134	001134	001134
Switch	133817	133817	133817	133817	133817	133817
Motor w/Switch & Cord	128758	128758	128758	128758	128758	139359

(*) Standard hardware item
 (†) Cast Iron — Plastic base not available
 (N/A) Not available
 (N/R) Not required

“98” SERIES JET PUMP MOTOR SERVICE PARTS (For Pricing Refer To Repair Parts Price List)

FORM NO. FW1164
0122
SUPERSEDES
1020

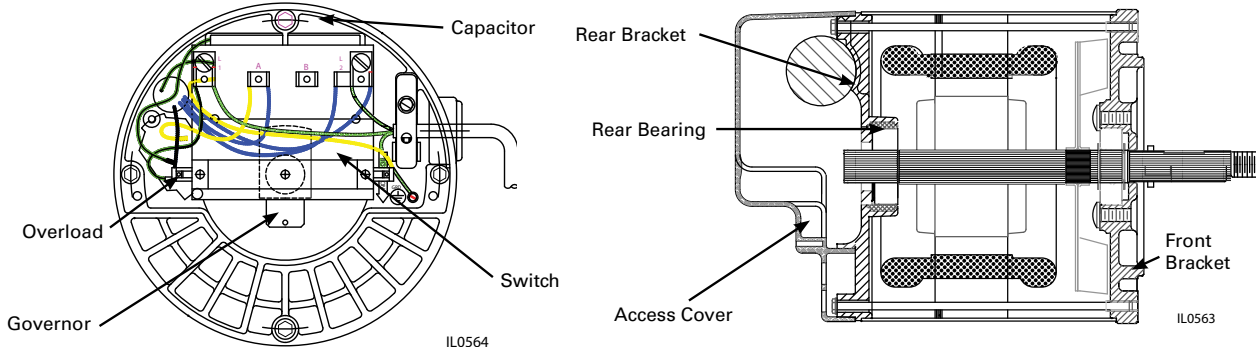

Parts List for 98 Series Motors		Part No.	SINGLE PHASE UNIFRAME						SINGLE PHASE										THREE PHASE							
			HP	1/3	1/2	3/4	1	1/2	3/4	1/3	1/3	1/2	3/4	1	1-1/2	2	1	1-1/2	3	1/2	3/4	1	1-1/2	2	3	
			SHAFT FLATTED																							
Description	Part No.																									
Switch & Governor † .567	022546
Switch & Terminal Board	137122A
Governor Kit ††	022545
Governor Only .567	022543
Capacitor	25 MFD	136656																								
	200 MFD	135884				
	282 MFD	135885	
	324 MFD	135886				
Overload Protector	136123						
	136124																									
	023519	
	022988	
	136127				
	136128											
	136129											
	136126					
Bearing & Housing	135309	
Bearing, Front	023076												
Bearing, Front	022962								
Bearing, Rear	022962	
Combination Bracket, Front	135314
	136115	
Bracket, Front	134390							
Bracket, Front	023078												
Bracket, Rear	136115	
Thru Bolts (4)	5-3/4"	136116
	6"	136117	
	6-1/2"	134512		
	7"	134513			
	7-5/8"	136118				
	8-1/8"	134515										
Access Cover, Rear*	021301R*	*	*	*	*	*	*	*	*	*	*	*	*	*	*	*	*	*	*	*	*	*	*	*	*	
Access Cover, Rear**	023212								**	**	**	**	**	**	**	**	**	**	**	**	**	**	**	**	**	
Access Cover, Screws (2)	021302																									

NOTE: Capacitor Cover 132539 is utilized on 98J610, 98J615 and 98J630 single phase motors.
 (†) To replace both the switch and governor, use switch & governor kit 022546. This kit applies to all 98 series motors regardless of date code. Kit 022546 contains governor, switch & terminal board, snap ring and spring washer
 (††) Governor Kit 022545 contains governor, snap-ring and spring washer
 (*) Access cover 021301R Includes cover, screws & wiring diagram
 (***) Access cover 023212 used on all 98H motors and all pressure booster pump motors. Includes cover, screws, wiring diagram and vertical motor cover kit.

General Offices	(260) 347-1600
Toll-Free	(800) 345-9422
Toll-Free Service	(800) 742-5044
Toll Free Water Conditioning	(800) 545-2206
Toll-Free Sales Department	(800) 927-0360
Toll-Free Sales Fax	(800) 848-2535
International Phone	+ 1 (260) 347-1600
International Sales Fax	+ 1 (260) 347-0909
International Correspondence Fax	+ 1 (260) 347-6664

Submersible Pumps

Variable Frequency Drives

Jet Pumps

Centrifugal Pumps

Booster Pumps

Specialty Pumps

Sump/Sewage Pumps



Flint & Walling is a family-owned American proud manufacturer of premium pumps, motors, and controls. Built on proven, comprehensive testing and generations of personal relationships with loyal customers and employees. With a legacy of high-quality products, trust flows through everything we do.

95 North Oak Street
Kendallville, IN 46755
260-347-1600 • Fax: 260-347-6664
www.FlintandWalling.com

