

# VERTICAL JET PUMPS

FW0636

0413

Supersedes

0909

## INSTALLATION INSTRUCTIONS & PARTS MANUAL

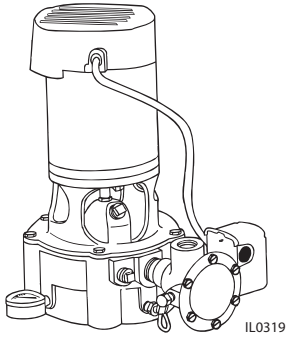

“VA” SERIES 1/2 - 1-1/2 HP  
FULLY AUTOMATIC  
CONTROL VALVE  
3/4 - 1-1/2 HP TWO STAGE

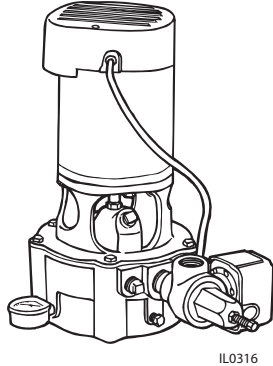

“VS” SERIES 1/2 - 1-1/2 HP  
SEMI AUTOMATIC  
CONTROL VALVE  
3/4 - 1-1/2 HP TWO STAGE

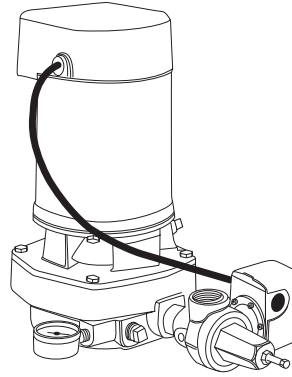

“VPH” SERIES - 1 HP  
SEMI AUTOMATIC  
CONTROL VALVE  
1 HP SINGLE STAGE

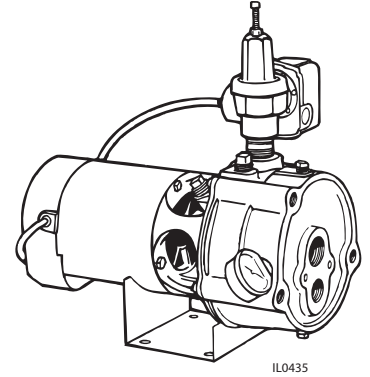

“VS” SERIES 1/2 - 1-1/2 HP  
HORIZONTAL POSITION  
USING OPTIONAL 135276  
PUMP BASE

## EJECTORS AND ADAPTERS



Single pipe ejector,  
leather packers  
for 2” wells

### STRAIGHT WELL ADAPTER

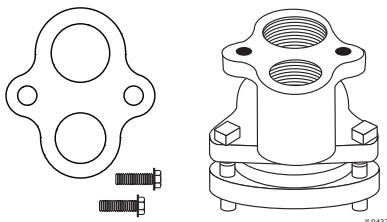

### RIGHT ANGLE WELL ADAPTER

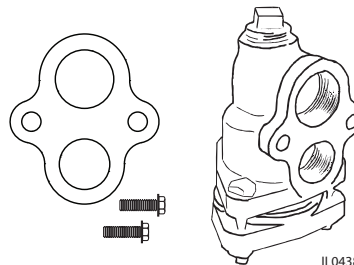

## MOTOR SPECIFICATION CHART

PUMP MODEL NO.	HP	STG.	NAMEPLATE MAX AMPS		MOTOR CONNECTED FOR	TAPPING SIZE INCHES			DIMENSIONS INCHES			
			115V	230V		DISCHG.	SUCTION	PRESS.	H	W	L	WT.
VS207P VA207P	3/4	2	18	9	230V	1"	1-1/4"	1"	17"	9-1/4"	15-1/8"	67 lb.
VPH10	1	1	18	9	230V	1"	1-1/4"	1"	15-1/2"	6-1/2"	14-1/2"	56 lb.
VS210P VA210P	1	2	21	10.5	230V	1"	1-1/4"	1"	17-5/8"	9-1/4"	15-1/8"	72 lb.
VS215P	1-1/2	2	25	12.5	230V	1"	1-1/4"	1"	18-1/8"	9-1/4"	15-1/8"	76 lb.

All motors are single phase 60 Hz., 3450 RPM.

Motor can be changed to either 115V or 230V by following diagram on motor decal.

Pressure switch settings are 30 - 50 PSI for the above models.

## EJECTOR SPECIFICATIONS AND WELL ADAPTER SELECTION CHART

EJECTOR ORDER NO.	EJECTOR DESCRIPTION	EJECTOR DROP PIPE TAPPING	WELL SIZE / DROP PIPE	WELL ADAPTER REQUIRED	
				PACKAGE NO.	TYPE
SP20BL	2" Brass, Leather	1" F 1-1/4" M	2" x 1"  2" x 1-1/4"*	129719	Straight
				127025	Rt. Angle
SP20CL	2" Cast Iron, Leather	1" F	2" x 1"	129719	Straight
				127025	Rt. Angle
SP22CL	2" Cast Iron, Leather	1-1/4" M	2" x 1-1/4"	129720	Straight
				129723	Rt. Angle

\*129205 1-1/4" turned coupling required. Order separately.

### READ THESE INSTRUCTIONS CAREFULLY

Read these installation instructions in detail before installing your pump. Be sure to check the following:

1. Be certain the motor is connected for the correct line voltage being used (check motor nameplate).
  2. Be certain the pump is completely primed before starting. Otherwise damage may occur to the seal.
- EVERY pump is tested before leaving the factory, and its performance depends largely on the installation.

### GENERAL SAFETY INFORMATION

- A. Follow all local electrical and safety codes, as well as the National Electrical Code (NEC) and the Occupational Safety and Health Act (OSHA).
- B. Replace or repair damaged or worn cords immediately.
- C. Do not kink power cable and never allow the cable to come in contact with oil, grease, hot surfaces, or chemicals.
- D. Protect the power cable from coming in contact with sharp objects.
- E. Be careful when touching the exterior of an operating motor--it may be hot enough to be painful or cause injury. With modern motors, this condition is normal if operated at rated load and voltage. Modern motors are built to operate at higher temperatures.
- F. Make certain that the power source conforms with the requirements of your equipment.
- G. Always disconnect power source before performing any work on or near the motor or its connected load. If the power disconnect point is out-of-sight, lock it in the open position and tag it to prevent unexpected application of power. Failure to do so could result in fatal electrical shock.
- H. Do not handle the pump with wet hands or when standing in water, as fatal electrical shock could occur. Disconnect main power before handling unit for ANY REASON!
- I. Unit must be securely and adequately electrically grounded. This can be accomplished by wiring the unit to a grounded metal-clad raceway system or by using a separate ground wire connected to the bare metal of the motor frame or other suitable means.
- J. WARNING: Risk of electric shock. This pump has not been investigated for use in swimming pool areas.
- K. WARNING: This product contains chemicals known to the State of California to cause cancer and birth defects or other reproductive harm.
- L. NOTE: Pumps with the "CSA" mark are tested to UL standard UL778 and certified to CSA standard C22.2 No. 108.

# PRELIMINARY CONSIDERATIONS

## I. Location

- A. Pump can be located at the well or can be offset some distance away from the well. For best performance, it should be located as close to the well as possible.
- B. Location can be in the basement, a pit below ground, or in a pump house above ground.
- C. Ventilation and drainage must be provided to prevent damage from moisture to the motor and pressure switch.
- D. The pump and all piping must be protected from freezing.
- E. Pump and pipe line must be drained when not in use if there is any danger of freezing.

## II. Well Conditions

- A. New wells should be pumped clean of all sand and foreign matter before installing the pump, or damage may result to the operating parts.
- B. The foot valve should be installed a minimum of five feet from the bottom of the well to prevent sand, mud or other foreign matter from entering the system.
- C. The well must be capable of furnishing a sufficient quantity of water to satisfy the demands of the pump and personal needs. The water level must not draw down below the maximum rated depth of the pump, or loss of capacity and prime will result.
- D. For weak well installations, see Paragraph A under Deep Well (Double Pipe System) installations.
- E. For sanitary reasons, install a well seal or pitless adapter as required and in accordance with local and state codes.

## III. Piping

- A. Old or badly scaled pipe should not be used, because dislodged flakes of scale can cause stoppage of the ejector nozzle and malfunction the entire system.
- B. Use only pipe in good condition, free of rust and scale. Threads should be sharp, cleanly cut and with a minimum of two threads remaining when connection is completely drawn up.
- C. On galvanized steel pipe installations, the ends should be reamed to ensure maximum capacity.
- D. All joints and connections should be doped (male threads only) and drawn up tightly.

**CAUTION: THE ENTIRE SYSTEM MUST BE AIR AND WATER TIGHT FOR EFFICIENT OPERATION**

## IV. Type of Pipe

- A. Plastic or galvanized steel pipe may be used in the installation of jet pumps.
- B. Plastic pipe must have a minimum pressure rating of 160 P.S.I.
- C. DO NOT USE PLASTIC PIPE IN THE WELL ON SINGLE PIPE EJECTOR INSTALLATIONS.

## V. Well To Pump Piping

- A. All offset piping should slope upwards from well to pump.
- B. Avoid dips or pockets in offset piping, or air will accumulate at high points and make priming difficult.
- C. Install unions at pump and at well to aid in servicing.
- D. Allow enough room around pump and piping installation for using pipe wrenches, and for service and installation.
- E. Do not use piping of sizes smaller than those listed in Chart 1, or pump will not operate properly.

<b>CHART I PIPE SIZES REQUIRED FOR HORIZONTAL PIPING BETWEEN PUMP AND WELL</b>						
Distance: Well to Pump	3/4 HP		1 HP		1-1/2 HP	
	Suc.	Press.	Suc.	Press.	Suc.	Press.
0' - 25'	1-1/4"	1"	1-1/4"	1"	1-1/4"	1"
25' - 50'	1-1/4"	1-1/4"	1-1/4"	1-1/4"	1-1/4"	1-1/4"
50' - 75'	1-1/4"	1-1/4"	1-1/4"	1-1/4"	1-1/4"	1-1/4"
75' - 100'	1-1/2"	1-1/4"	1-1/2"	1-1/4"	1-1/2"	1-1/4"
100' - 125'	1-1/2"	1-1/2"	1-1/2"	1-1/2"	1-1/2"	1-1/2"
125' - 150'	1-1/2"	1-1/2"	1-1/2"	1-1/2"	1-1/2"	1-1/2"

**NOTE - USE PIPE JOINT COMPOUND ON EXTERNAL THREADS OF ALL CONNECTIONS**

## INSTALLATION

### I. Deep Well (Double Pipe System)

Application - Where the inside diameter of well is 3-1/2 inches or larger. (See illustration C & D).

- A. Attach the foot valve to the ejector using a galvanized steel or plastic nipple. Add sufficient pressure pipe (1") and suction pipe (1-1/4") to submerge ejector 10 to 15' below pumping water level, making certain foot valve is at least 5 feet from bottom of well. If pressure pipe and suction pipe of the same diameter are used, be sure to identify them clearly so that they will be connected to the proper tappings of the pump.

If a known weak well exists, replace nipple with 34 feet of 1" tail pipe between the ejector and the foot valve. This will provide a continuous source of water for the pumping system.

- B. Check pipe and foot valve for leaks by filling pipes with water. A continuous loss of water indicates a leak in the piping, foot valve or unions, and must be corrected.
- C. If no leaks are found, connect pressure and suction pipes from well to pump using piping of the same diameter as the suction pipe (1-1/4") and pressure pipe (1") tappings of the pump. For long offset distances, refer to Chart I. for the proper pipe size.
- D. Unions in suction and discharge piping near pump and well will aid in servicing. Leave enough surrounding room so that wrenches can be used without difficulty.

## II. Deep Well (Single Pipe System)

Application - Where the inside diameter of well is 2, 2-1/2 or 3 inches (See Illustration A & B).

- A. Attach foot valve directly to bottom of ejector assembly (tail pipe not used on single pipe installations). Ejector is to be submerged 10 to 15 feet below pumping water level, making certain foot valve is at least five feet from bottom of well.
- B. Attach foot valve and packer ejector to suction pipe (presoak packer leathers for approximately two hours). Start the assembly down the well. Some force may be required to push the packer down the casing.
- C. As each section is lowered, check for leaks by pouring water into the suction pipe.
- D. Attach well adapter to suction pipe, lower over casing top and tighten adapter flange.
- E. If pump is offset from the well, run suction and pressure pipes from well to pump, using piping of the same diameter as the suction tapping (1-1/4") and pressure tapping (1" of the pump. For long offset distances, refer to Chart I for the proper pipe size.
- F. Unions in suction and discharge piping near pump and well will aid in servicing. Leave enough surrounding room so that wrenches can be used without difficulty.

## III. Pressure Tank Hook Up

- A. Standard vertical pressure tanks require an air volume control to ensure the proper air-to-water ratio in the pressure tank. The air volume control tubing is connected to the 1/4" tapping on the pump case (see Illustration E).
- B. Air-E-Tainer tanks are equipped with a diaphragm or bladder that keeps the air and water from mixing. Since these tanks are factory precharged with air, an air volume control is not required.
- C. On vertical tank installations, galvanized steel or plastic pipe can be used to connect the pump to the tank. To assist in servicing, place shut-off valve and union in line between pump and tank (See Illustration E).
- D. **DO NOT install a check valve between pump and pressure tank. This will cause the pressure switch to malfunction.**

## IV. Wiring

- A. All jet pump motors are suitable for use with 60 cycle A.C. current only. Pumps with 3/4 thru 1-1/2 HP motors are connected for 230 volt service.
- B. All pumps (3/4 thru 1-1/2 HP) are dual voltage and may be field connected for either 115 or 230 volt service.
- C. Check the motor nameplate diagram if a voltage change is required. Always use the higher voltage when possible.

Your pump motor has built-in thermal overload that protects the motor against burnout from overload of low voltage, high voltage and other causes. The device is automatic and resets itself once the temperature has dropped to a safe point. Frequent tripping of the device indicates trouble in the motor or power lines, and immediate attention is needed. The device should never be tampered with, and unless trouble is located and corrected, motor failure can eventually be expected.

CHART II-A RECOMMENDED WIRE AND FUSE SIZES	
MAX. FUSE CAPACITY	WIRE GAUGE
15A	14
20A	12
30A	10
45A	8
60A	6

CHART II-B RECOMMENDED WIRE SIZES			
Distance From Motor To Meter	HP Rating of Single Phase Motors		
	3/4	1	1-1/2
0-50'			
115V	12 GA	12 GA	12 GA
230V	14 GA	14 GA	14 GA
50-100'			
115V	12 GA	12 GA	12 GA
230V	14 GA	14 GA	14 GA
100-150'			
115V	12 GA	10 GA	10 GA
230V	14 GA	14 GA	12 GA
150-200'			
115V	10 GA	10 GA	8 GA
230V	14 GA	12 GA	12 GA
200-300'			
115V	8 GA	8 GA	6 GA
230V	14 GA	12 GA	10 GA

**CAUTION: Never examine, make wiring changes or touch the motor before disconnecting the main electrical supply switch. The thermal device may have opened the electrical circuit.**

- D. Undersize wiring can cause motor failure (low voltage), frequent cutout of motor overload protector, television interference and even fire. Make certain the wiring is adequately sized (Chart II-B), well insulated and connected to a separate circuit outside the house in case of fire. For added safety, the pump and motor should be securely grounded to the well casing or to a separate ground rod driven eight feet into the ground. Consult local codes before attempting a wiring installation.

NOTE: Charts II-A and II-B assume copper wire to be installed.

- E. When fusing the pump service entrance box, consult Chart II-A for proper fuse size. Use only the fuse that is stipulated for your particular installation. Never use one larger. Service should never be reinstated to the pump motor by attempting to circumvent a blown fuse by any other means.

- F. The pressure switch is wired to the motor by connecting the motor lead to the two inside terminals of the pressure switch. Connect the power lines to pressure switch terminals marked L-1 and L-2.

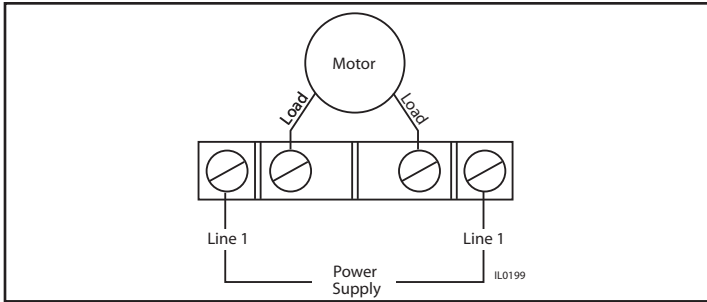

## PRIMING & ADJUSTMENT

**CAUTION: Before starting motor, the pump body must be completely filled with water. Running the pump dry will cause seal damage.**

### I. Pumps With Fully Automatic Control Valve

- Remove priming plug from pump. Fill pump body completely with water until all air has been expelled. Replace plug.
- Start pump. If pump is properly primed, pressure will build quickly and register on the pressure gauge. If pressure does not build, repeat the priming operation.

ON DEEP WELL INSTALLATIONS, ALL AIR MUST BE VENTED FROM THE DRIVE AND SUCTION PIPES AS WELL AS THE PUMP BODY BEFORE THE PUMP WILL PRIME. IT MAY BE NECESSARY TO FILL THE PUMP BODY SEVERAL TIMES TO ACHIEVE PRIME.

- Once prime is achieved, unit will adjust automatically to the average operating pressure.

### II. Pumps With Semi-Automatic Control Valve

- Remove priming plug from pump. Fill pump body completely with water until all air has been expelled. Replace plug.
- Screw adjusting stem on control valve all the way in, then start the pump. If the pump is properly primed, pressure will build quickly and register on the pressure gauge. If pressure does not build, repeat the priming operation.
- With the pump operating at high pressure and no pressure in the tank (two or more faucets open) slowly unsew the adjusting stem until maximum flow is obtained. The case pressure at this point will be the average operating pressure and should agree with the chart shown below.
- If the control valve is opened too far, a slight cavitation noise will be noticeable and still further opening will cause the pump to lose prime.

AVERAGE OPERATING PRESSURE		
MODEL NO. SETTING	HP	PRESSURE
VS, VA207P	3/4	46 PSI
VS, VA210P	1	57 PSI
VS, VA215P	1-1/2	72 PSI
VPH10	1	47 PSI

NOTE: PUMP WILL NOT PRIME IF THERE IS ANY LEAKAGE IN THE SUCTION PIPING.

### III. Pumps Installed In A Horizontal Position

- “VA” and “VS” pumps can be installed horizontally by using the optional 135276 pump base.
- If installed horizontally, prime through the priming port of the pump body.
- By following this procedure, the entire pump cavity can be filled with water and air will be expelled more readily.

## MAINTENANCE

### A. LUBRICATION

The pumps and motors require no lubrication. The ball bearings of the motor have been pre-lubricated and under normal operating conditions should require no further greasing.

### B. FREEZING

Drain the entire system if there is danger of freezing. A drain plug is provided at the bottom of the pump case for this purpose.

## ROTARY SEAL ASSEMBLY

### REPLACEMENT

**CAUTION: Make certain that the power supply is disconnected before attempting to service the unit! The rotary seal assembly must be handled carefully to avoid damaging the precision lapped faces of the sealing components.**

- Disengage pump body from motor and mounting ring.
- Remove diffuser and unthread impeller from the pump shaft.

NOTE: To prevent the shaft from rotating when removing the impeller, use an 11/16” open end wrench on the hex of the pump shaft.

- The carbon seal face, friction ring, and stainless steel shell & spring of the rotary seal will come loose at this time. Use a screwdriver (or similar instrument) to pry the ceramic seal and rubber gasket from the recess of the mounting bracket.

**CAUTION: Be careful not to damage the motor shaft or recess surface.**

- Clean the recess and pump shaft thoroughly.



E. Install the new rotary seal assembly:

1. Insert the ceramic seal and the rubber gasket into the recess.

NOTE: To help facilitate installation, apply a light coating of oil to the outside diameter of the rubber gasket. Make certain that the ceramic seal is kept clean and free of dirt and/or oil.

2. Slip the remaining parts of the rotary seal assembly onto the motor shaft.

NOTE: Apply a light coating of oil to the inside diameter of the rubber drive ring.

F. Replace the impeller and diffuser removed in Step B.

G. Reassemble the pump body to the motor and mounting bracket.

## MOTOR REPLACEMENT

**CAUTION: Before attempting to replace the motor, make certain that the power supply is disconnected and the systems pressure is relieved.**

- A. The motor can be removed without disturbing the seal assembly or hydraulic components of the pump. Make certain that the service factor of the replacement motor corresponds with the motor being replaced.
- B. Remove four bolts that hold the motor to the motor mounting ring.
- C. Break the motor shaft free from the pump shaft by using an 11/16" wrench on the pump shaft and a 9/16" wrench on the flats of the motor shaft. Unthread motor shaft while holding the pump shaft.
- D. Reassemble the new motor.

## TROUBLESHOOTING CHART

SYMPTOM	POSSIBLE CAUSE(S)	CORRECTIVE ACTION
<b>PUMP WON'T START OR RUN</b>	<ol style="list-style-type: none"> <li>1. Blown fuse</li> <li>2. Low line voltage</li> <li>3. Loose, broken or incorrect wiring</li> <li>4. Defective motor</li> <li>5. Defective pressure switch</li> <li>6. Impeller or seal</li> <li>7. Bad capacitor</li> </ol>	<ol style="list-style-type: none"> <li>1. If blown, replace with fuse of proper size. Use time delay fuses.</li> <li>2. If voltage under recommended minimum, check size of wiring from main switch on property. If OK, contact power company.</li> <li>3. Rewire any incorrect circuits. Tighten connections, replace defective wires.</li> <li>4. Replace</li> <li>5. Adjust switch settings. Clean contacts with emery cloth, if dirty.</li> <li>6. If impeller won't turn, remove housing and locate source of binding.</li> <li>7. Replace.</li> </ol>
<b>PUMP STARTS AND STOPS TOO OFTEN</b>	<ol style="list-style-type: none"> <li>1. Leak in pressure tank</li> <li>2. Defective air volume control</li> <li>3. Faulty pressure switch</li> <li>4. Leak on discharge side of system</li> <li>5. Leak on suction side of system</li> <li>6. Leak in foot valve</li> </ol>	<ol style="list-style-type: none"> <li>1. Repair leaks or replace tank.</li> <li>2. Clean or replace defective control.</li> <li>3. Adjust switch settings. Clean contacts with emery cloth, if dirty.</li> <li>4. Repair leaks as necessary.</li> <li>5. Make sure above ground connections are tight. Then repeat test. If necessary, pull piping and repair leak.</li> <li>6. Repair or replace.</li> </ol>
<b>PUMP WON'T SHUT OFF</b>	<ol style="list-style-type: none"> <li>1. Wrong pressure switch setting, or setting "drift"</li> <li>2. Defective pressure switch</li> <li>3. Loss of prime</li> <li>4. Low well level</li> <li>5. Fouled ejector</li> </ol>	<ol style="list-style-type: none"> <li>1. Adjust switch to proper setting.</li> <li>2. Replace switch if defective.</li> <li>3. Reprime if necessary.</li> <li>4. If undersized, replace pump or ejector.</li> <li>5. Clean.</li> </ol>
<b>PUMP OPERATES, BUT DELIVERS LITTLE OR NO WATER</b>	<ol style="list-style-type: none"> <li>1. Low line voltage</li> <li>2. System incompletely primed</li> <li>3. Air lock in suction line</li> <li>4. Undersized piping</li> <li>5. Leak in air volume control or tubing</li> <li>6. Leak on suction side of system</li> <li>7. Low well capacity</li> <li>8. Plugged ejector</li> <li>9. Defective or plugged foot valve and/or strainer</li> <li>10. Worn or defective pump parts or plugged impeller</li> </ol>	<ol style="list-style-type: none"> <li>1. If voltage under recommended minimum, check size of wiring from main switch on property. If OK, contact power company</li> <li>2. Reprime if necessary.</li> <li>3. Rearrange piping to eliminate air lock.</li> <li>4. Replace undersized piping or install pump with higher capacity.</li> <li>5. Tighten all fittings and replace control if necessary.</li> <li>6. Make sure above ground connections are tight. Then repeat test. If necessary, pull piping and repair leak.</li> <li>7. Close down the valve on the discharge side of pump to limit the flow of water, in keeping with well capacity.</li> <li>8. Clean and reinstall if dirty.</li> <li>9. Clean, repair, or replace as needed.</li> <li>10. Replace worn parts or entire pump. Clean parts if required.</li> </ol>

## DEEP WELL JET PUMP REPAIR PARTS “VA”, “VS” & “VPH” SERIES (For Pricing Refer To Repair Parts Price List)

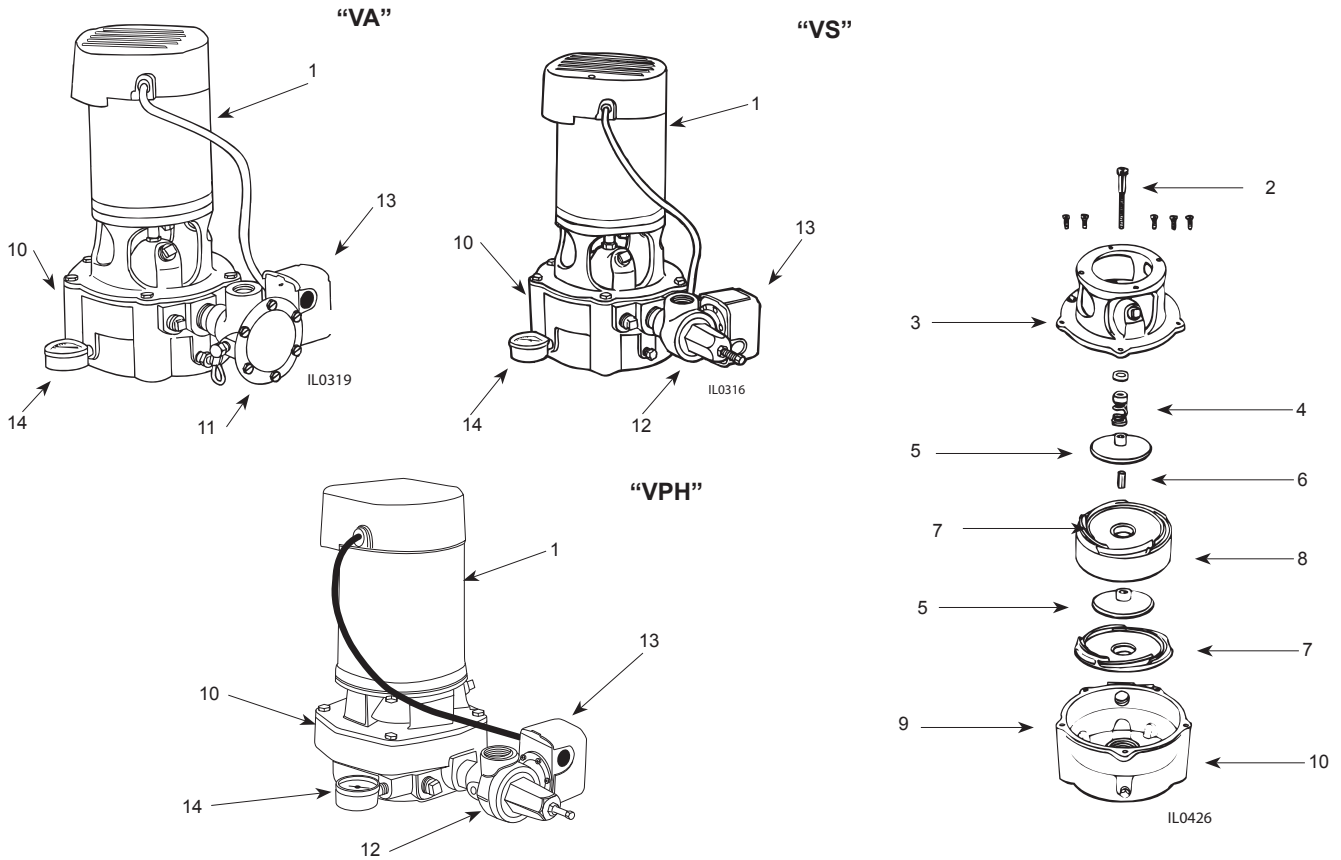

ITEM	DESCRIPTION	HORSEPOWER	1/2	3/4	1	1-1/2	1
		STAGE	1	2	2	2	1
		MODEL NO.	VA105P VS105P	VA207P VS207P	VA210P VS210P	VA215P VS215P	VPH10
		PART NO.	QTY.				
1	Motor, Nema J (Thd) Motor Cover w/screws Screws Cover Motor Lead Wire	023212 021302	98H105 1 2 136135A	98H107 1 2 136135A	98H110 1 2 136135A	98H115 1 2 136136A	98J110 1 2 136135A
2	Shaft	135238	135238	135239	135239	135239	N/R
3	Mounting Ring	135235	1	1	1	1	136873
	Hex Hd. Cap Screws 3/8 x 3/4"	*	9	9	9	9	8
4	Seal, Rotary w/Spring	131100	1	1	1	1	1
5	Impeller †		135248	127960	132613	135248	134138
6	Spacer, Shaft	135245	—	1	1	1	—
‡	Spacer, Suction	135243	1	—	—	—	—
7	Diffuser †		135242	135241	135241	135242	132425
8	Intermediate Stage	135246	—	1	1	1	—
‡	Bearing, Intermediate Stage	135247	—	1	1	1	—
9	Ring, Square Cut	135240	1	1	1	1	132429
‡	Rubber, Diffuser	132428	—	—	—	—	1
10	Pump Body	135237	1	1	1	1	134312
11	Control Valve “VA”		C981D	C981G	C981G	C981G	—
12	Control Valve “VS” & “VPH”		132446	133383	133383	133383	132446
13	Pressure Switch	020346	1	1	1	1	1
14	Pressure Gauge	023294	1	1	1	1	1
‡	Plug, Priming 1/2" NPT	*	2	2	2	2	2
‡	Plug, Drain 1/4" NPT	*	1	1	1	1	1

(\*) Standard hardware item

(†) For quantity required — See number of stages

(‡) Not shown

NOTE: For horizontal installations, use optional pump base 135276A

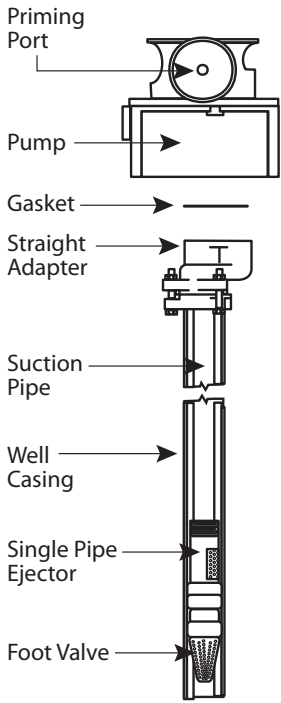

Illustration (A)  
Single Pipe Over the Well  
Installation

IL1707

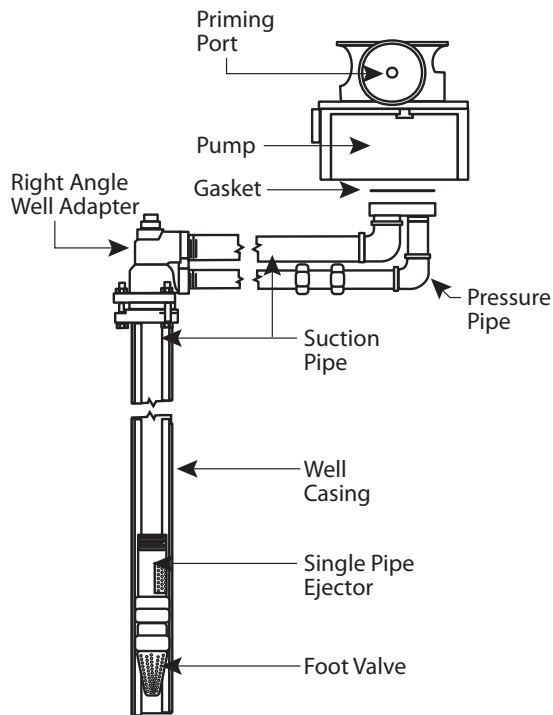

Illustration (B)  
Single Pipe Offset  
Installation

IL1708

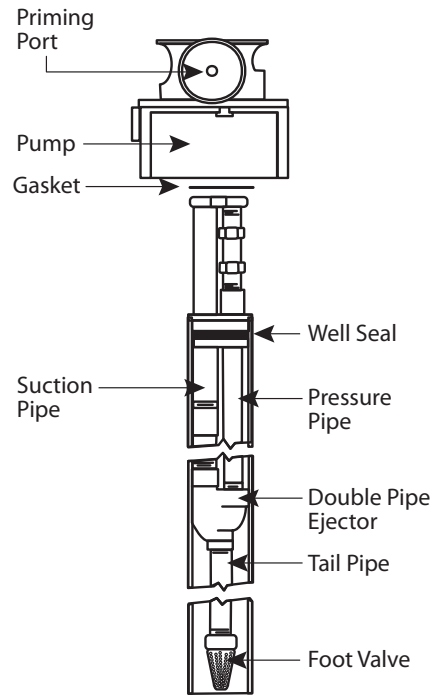

Illustration (C)  
Double Pipe Over the Well  
Installation

IL1709

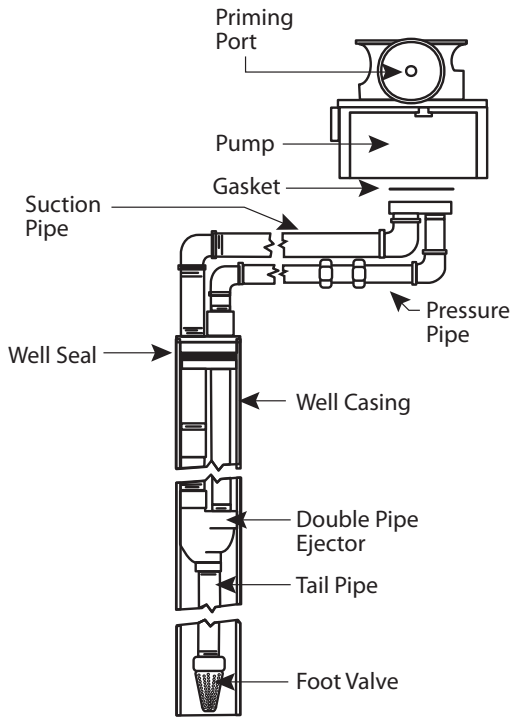

Illustration (D)  
Double Pipe Offset  
Installation

IL1710

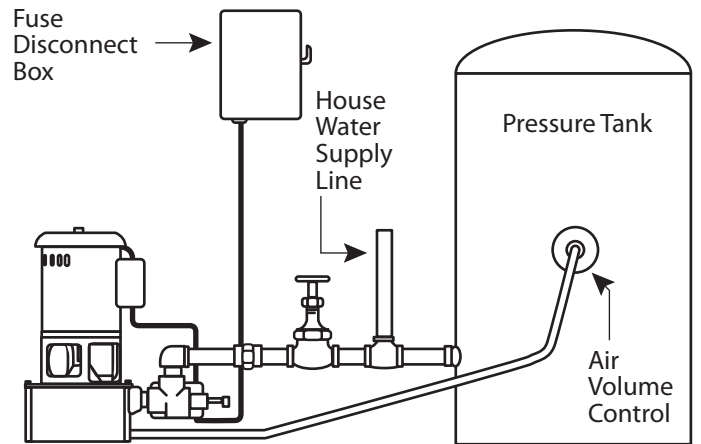

Illustration (E)  
Pressure Tank  
Installation

IL1711