

# 4" SUBMERSIBLE MOTORS AND CONTROL BOXES

FW1637  
0724  
Supersedes  
0922

## Motor Application Guide

Flint & Walling 4" Submersible Motors provide quality in the details:

- Nitrile rubber shaft seal . . . three-part design protects motor from contamination
- Stainless steel shaft . . . features polished bearing journals for extended bearing life
- Copper-wound stator for superior performance
- Stainless steel carbon graphite Kingsbury thrust bearing . . . provides self-aligning axial support up to 700 lbs. for reliable operation
- Stainless steel shell . . . hermetically sealed for maximum corrosion resistance
- Precision-ground radial bearings . . . for high load capability and long life



**Motors: 1/2 through 2 HP**

**2-Wire and 3-Wire Single Phase and Three Phase**

**Control Boxes: 1/2 through 5 HP**

024601 D

  
US  
LR90197  
Drinking Water  
NSF/ANSI 61

  
**FLINT & WALLING**



# 4" Submersible Motors

## STAINLESS STEEL MOTORS

### Lead Assembly

4 ft., field-serviceable encapsulated cordset protects leads from water intrusion

### Shaft Seal System

Three-part design protects motor from contamination

### Stator End Bells

Robust cast construction for precision bearing alignment and long life

### Stainless Steel Shaft

Features polished bearing journals for extended bearing life

### Internal Fill Solution

Features polished bearing journals for extended bearing life



### Kingsbury Thrust Bearing

Provides self-aligning axial support up to 700 lbs for reliable operation

### Laser-welded Stator

Prevents water intrusion

### Spline

NEMA design resists mechanical wear

### Shell and Stator Ends

Stainless steel and hermetically sealed for maximum corrosion resistance

### Stator Assembly

Encapsulated for maximum thermal conductivity, mechanical integrity and vibration resistance

### Copper Wound Stator

For superior performance

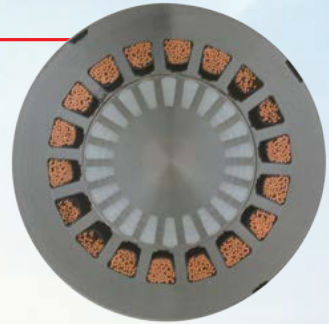

### Die Cast Rotor

Precision machined for maximum motor efficiency

### Radial Bearings

Precision ground for high load capability and long life



Other questions? Let's talk.  
800.584.8089 or visit [FlintandWalling.com](http://FlintandWalling.com) to locate a distributor near you.

Flint & Walling • 95 North Oak Street • Kendallville, IN 46755 • [FlintandWalling.com](http://FlintandWalling.com)  
© 2023 Flint & Walling, Inc. All rights reserved. Flint and Walling Inc. asserts trademark and copyright rights in the Flint & Walling logo.



### TESTED. TO THE CORE.

**Lead Assembly –**  
4 ft., field-serviceable encapsulated cordset protects leads from water intrusion.

**Spline –**  
NEMA design resists mechanical wear.

**Shaft Seal System -**  
Three-part design protects motor from contamination.

**Stator End bells –**  
Robust construction for precision bearing alignment and long life.

**Stator Ends -**  
Coated carbon steel, hermetically sealed for maximum corrosion resistance.

**Stainless Steel Shaft -**  
Features polished bearing journals for extended bearing life.

**Stator Assembly –**  
Encapsulated for maximum thermal conductivity, mechanical integrity and vibration resistance.

**Copper Wound Stator –**  
For superior performance

**Internal Fill Solution –**  
NSF approved water based, proprietary lubricating system for superior motor cooling and extended bearing life. (Not shown)

**Kingsbury Thrust Bearing -**  
Provides self-aligning axial support up to 700 lbs. for reliable operation.

**Die Cast Rotor –**  
Precision machined for maximum motor efficiency.

**Laser-welded Stator -**  
Prevents water intrusion

**Radial bearings –**  
Precision ground for high load capability and long life.

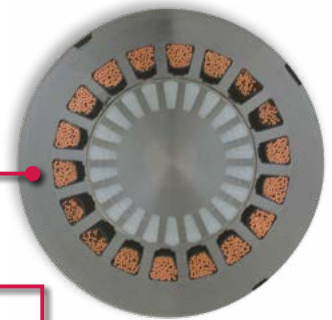

# 4" Submersible Motors

## STORAGE AND HANDLING

Long and reliable motor life is supported by Flint & Walling proprietary NSF food safe internal motor fill solution, acting as a lubrication solution for the bearing system and shaft lip seal. The anti-corrosive additives prevent internal corrosion and promote long running life.

Long term storage should be limited to 115° F. During horizontal storage, fill solution may weep through the check valve, creating slight loss of liquid. This is not a concern for the running performance of the motor. Cold storage down to -30° F will not damage the motor due to the anti-freeze protection provided by the fill solution.

## INSTALLATION – VERTICAL VS. HORIZONTAL POSITION

The pump is designed to be vertically positioned with the pump end up. The pump applies down thrust onto the motor, which seats the axial bearing firmly into the running position. If the application requires the pump to be placed horizontally, it is important to provide a minimum 10 degree angle (motor in the down position), decrease the starts per day, and avoid open flow pump applications to prevent motor bearing damage. Depending upon the specific application, this will minimize the impact to motor life.

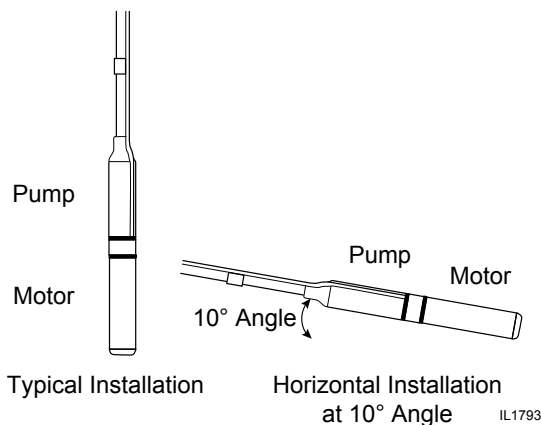

## DROP PIPE INSTALLATION

Drop pipe threads and pump discharge must be tightened to 20 lb-ft to withstand loosening caused by rotational inertia generated from the starting torque of the pump.

To center the pump and protect the wire, a submersible cable guard is recommended. A torque arrestor is also suggested to minimize pump twisting caused by motor start torque. Plastic pipe installations should always use torque arrestors.

## CHECK VALVE INSTALLATION

The F&W pump has a pre-assembled check valve within the discharge. Check valves effectively hold a column of water within the drop pipe which maintains water within the system. This prevents back spinning and water hammer. Additional check valves are required every 100 feet of vertical drop and one additional check valve within the horizontal run from the well site to the point of use.

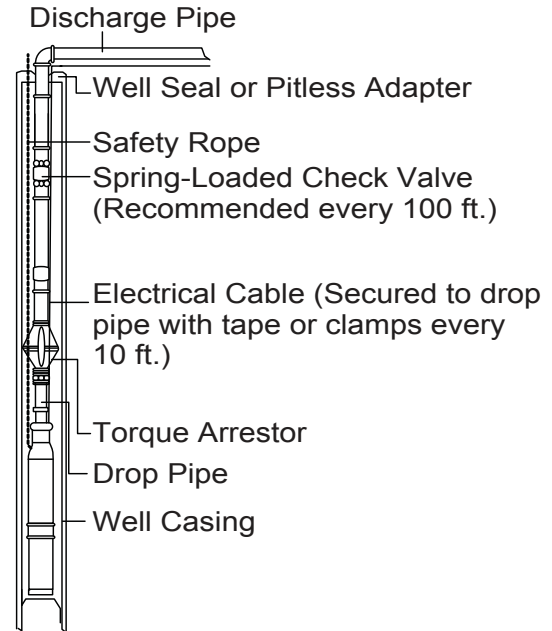

## MAX WATER TEMPERATURE LIMITS

Submersible motors are designed to run within 86°F. water temperature without the need for a flow inducer sleeve.

If water temperature exceeds 86°F, installed in a large body of water, storage tank or large well casing, contact F&W Technical Service at 1-800-742-5044 for flow inducer sleeve application.





# 4" Submersible Motors

## GROUNDING CONTROL BOXES AND PANELS

The National Electric Code requires that all control boxes and panel-grounding terminals be connected to the supply ground. A wire at least as large as the line conductor must be used to connect the grounding terminal to the electrical supply ground if the circuit has no grounding conductor and no metal conduit from the box to the supply panel.

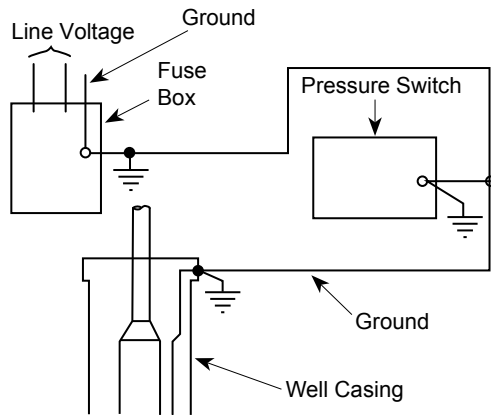

Note: It is recommended that all electrical work is completed by a licensed and trained professional. Follow all local and national codes.

**WARNING:** Failure to ground the box frame can result in a fatal electrical shock hazard if a circuit fault occurs.

**WARNING:** Serious or fatal electrical shock may result from failure to connect all metal plumbing, and the motor if outside a drilled well, to the power supply grounding terminal with wire no smaller than motor cable wires.

**WARNING:** This motor has not been approved for use in swimming areas.

## PROPER GROUNDING OF SUBMERSIBLE MOTORS

1. The purpose of grounding any electrical apparatus is to prevent an electrical shock hazard if exposed metal becomes connected to an electrical circuit. This can occur from physical damage, or a breakdown in the insulation. Grounding prevents shock hazard by keeping exposed metal from reaching a voltage level which could endanger anyone coming in contact with the electrical equipment. Fault current is "drained" by the ground conductor, and if the fault is severe enough, the circuit will be opened by the fuse or circuit breaker.

2. Section 250-43 item (K) of the U.S. National Electrical Code (NEC) requires that motor operated water pumps, including the submersible type, regardless of voltage, shall be grounded. Section 26-954 of the Canadian Electrical Code specifically discusses grounding requirements for submersible pumps. Additional codes may vary in different states and localities, but all applicable national, state, and local codes should always be followed. Code questions should be directed to your local electrical inspector.

NOTE: Always disconnect all power when making ohmmeter checks and while pulling or installing a pump.

3. The submersible motor is normally grounded as follows:
  - a. Run an extra wire with the motor power conductors. This wire must be sized to meet Table 250-95 in the U.S. National Electrical Code.
  - b. The ground wire may be insulated or bare. If insulated, it must be green with or without yellow stripe(s). The ground wire may be part of, or separate from, the supply cable. It may be continuous or spliced above the pump along with the supply cable.
  - c. Connect the green or bare ground wire to the green ground wire of the submersible motor lead wire assembly.
  - d. Connect the other end of ground wire to the power supply grounding terminal or to the control panel ground bar if it is connected to the power supply ground.
  - e. All connections should be tight and corrosion resistant. Screws, lugs, or clamps should be made of corrosion resistant material.

In abnormally corrosive water, the ground wire connection could be compromised. In a corrosive water application, F&W advises the use of a GFCI with a 10m A trip point. Route the ground wire through the current sensing device with the motor supply leads to provide additional protection.

## 2-WIRE (PLUS GROUND) MOTOR OPERATION.

The 2 - wire motor has an internal switch designed to energize the start winding during motor start up. A control box should not be used.

The 2 - wire switch design requires a minimum time of 10 seconds between starts after power is removed from the motor. This is to insure that the internal switch resets, places the start winding into the circuit, and allows proper restart of the motor.



# 4" Submersible Motors

## SINGLE PHASE - MAXIMUM COPPER CABLE LENGTHS IN FEET (SERVICE ENTRANCE TO MOTOR)

### 60°C Insulation

VOLTS	HP	WIRE SIZE (AWG)												
		14	12	10	8	6	4	3	2	1	0	00	000	0000
		LENGTH IN FEET												
115	1/2	105	160	265	400	625	950	1150	1470	1780	2140	2475	3010	3510
	1/2	420	650	1070	1615	2500	3810	4620	5880	7115	8570			
230	3/4	315	485	800	1210	1875	2855	3465	4410	5335	6425	7425		
	1	245	375	615	930	1440	2200	2665	3390	4105	4945	5710		
	1.5 (3W)	205	320	530	800	1240	1905	2320	2965	3615	4375	5085		
	1.5 (2W)	190	295	490	740	1145	1745	2115	2690	3260	3925	4535		
	2	160	250	415	635	1000	1550	1905	2465	3060	3750	4415		

### 75°C Insulation

VOLTS	HP	WIRE SIZE (AWG)												
		14	12	10	8	6	4	3	2	1	0	00	000	0000
		LENGTH IN FEET												
115	1/2	100	155	255	385	595	910	1105	1410	1710	2060	2384	2905	3400
	1/2	400	620	1020	1540	2390	3645	4420	5635	6836	8245			
230	3/4	300	465	765	1155	1790	2735	3315	4230	5130	6185	7155	8720	
	1	230	355	590	890	1380	2100	2250	3255	3945	4755	5500	6705	7845
	1.5 (3W)	200	305	505	765	1190	1825	2220	2840	3470	4205	4890	6010	7085
	1.5 (2W)	185	280	465	705	1095	1670	2025	2580	3130	3775	4368	5325	6230
	2	155	240	395	605	955	1480	1820	2360	2925	3590	4230	5315	6395

## THREE PHASE - MAXIMUM COPPER CABLE LENGTHS IN FEET (SERVICE ENTRANCE TO MOTOR)

### Three-Phase 60°C & 75°C Insulation

VOLTS	HP	WIRE SIZE (AWG)												
		14	12	10	8	6	4	3	2	1	0	00	000	0000
		LENGTH IN FEET												
230	1/2	930	1490	2350	3700	5760	8910							
	3/4	670	1080	1700	2580	4190	6490	8060	9860					
	1	560	910	1430	2260	3520	5460	6780	8290					
	1.5	420	670	1060	1671	2610	4050	5030	6160	7530	9170			
	2	320	510	810	1280	2010	3130	3890	4770	5860	7170	8780		
460	3	240	390	620	990	1540	2400	2980	3660	4480	5470	6690	8020	9680
	1/2	3770	6020	9460										
	3/4	2730	4350	6850										
	1	2300	3670	5770	9070									
	1.5	1700	2710	4270	6730									
460	2	1300	2070	3270	5150	8050								
	3	1000	1600	2520	3970	6200								

Lengths listed meet the NEC ampacity requirements for either individual conductors or jackets 60°C or 75°C cable and can be in conduit or direct buried.

NEC and local codes should be followed and observed for any other cable being used.

Cable lengths listed are calculated to allow a 5% voltage drop per NEC for alternating current. If a 3% voltage drop is desired, the values listed should be multiplied by 0.6 to obtain the maximum cable length.

## MOTOR DIMENSIONS

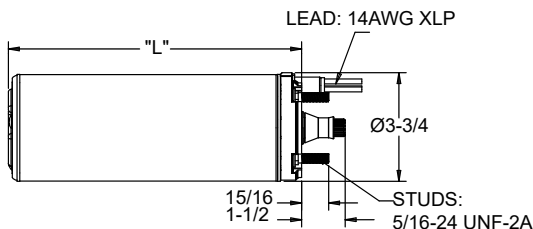

SINGLE PHASE		"L"	
HP	Wire	SS	E
1/2	2 and 3	10.10	10.47
3/4	2 and 3	11.23	11.60
1	2 and 3	12.10	12.47
1-1/2	2	15.43	N/A
1-1/2	3	14.06	14.35
2	3	15.43	N/A

THREE PHASE		"L"
HP	Wire	SS
1/2	3	10.10
3/4	3	11.23
1	3	11.23
1-1/2	3	12.10
2	3	14.06
3	3	15.56



# 4" Submersible Motors

## SUBMERSIBLE CONTROL BOXES

Model	HP	Volt	Amp	KW	Phase	Weight		Size (In.)
						Lbs.	KG	
022875	1/2	115	12	0.37	1	3	1.4	9 x 3.5 x 5.5
022876	1/2	230	6	0.37	1	3	1.4	9 x 3.5 x 5.5
022877	3/4	230	8	0.55	1	3	1.4	9 x 3.5 x 5.5
022878	1	230	10.4	0.75	1	3	1.4	9 x 3.5 x 5.5
022879	1-1/2	230	8.0/11.5	1.10	1	6.8	3.1	9.5 x 5.9 x 7.7
025242	2	230	13.2	1.50	1	7.1	3.2	9.5 x 5.9 x 7.7
025243	3	230	17	2.20	1	7.1	3.2	9.5 x 5.9 x 7.7
025244	5	230	27.5	3.70	1	10	4.5	15.7 x 5.9 x 7.8



### FEATURES:

- Universal voltage/potential relay
- Side and bottom knockouts for easy wire installation
- Designed for indoor/outdoor installations NEMA 3R
- Interchangeable with industry control boxes
- Heavy-duty terminal block for secure connections

### Deluxe 2, 3, & 5 HP Drive Features 025242, 025243, 025244

- **NEMA 3R Powder Coated Enclosure**  
Rated for indoor / outdoor applications
- **Wall or Center Mount**  
3-screw mounting pattern for wall or post mount applications
- **2-Pole Contactor in the 2HP and 3HP**  
**3-Pole Contactor in the 5HP**  
CSA / CE listed with quick-connect coil terminals
- **Premium Terminal Block**  
The terminal block is well labeled and accepts #6 cable. Additional "hand space" provided for ease of wiring
- **2 Pump Protection Overloads**  
Saves wear on the pump
- **Run & Start Capacitors**  
Heavy duty & Made in the USA
- **Multiple Size Knockouts**
- **Overload Reset Buttons**
- **Relay**  
Located front & center for easy access & removal. Reliable voltage relay. Made in the USA
- **Mechanical Ground**  
Deluxe copper mechanical ground

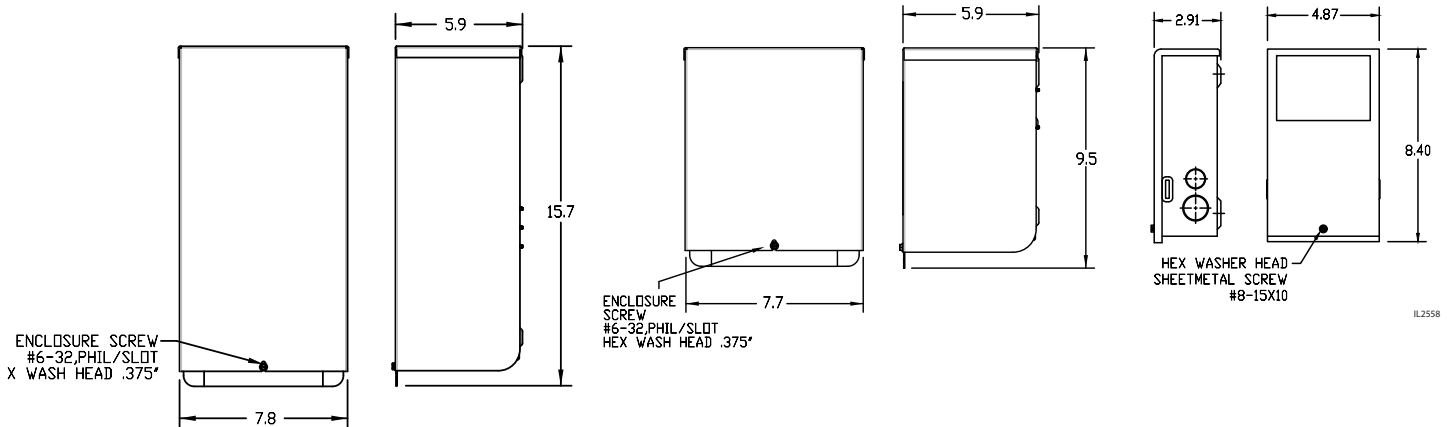

# 4" Submersible Motors

### 60HZ SINGLE PHASE MOTOR TABLE

	HP	KW	Voltage	Full Load			S.F.	Service Factor Load (Maximum Values)			Winding Res. Ohms	LR Amps	KVA Code
				Amps	Watts	%Eff F.L.		S.F. Amps	S.F. Watts	%Eff S.F.			
2 Wire	1/2	0.37	115	10	740	50	1.6	12	960	62	1.1-1.4	64	R
	1/2	0.37	230	5	740	50	1.6	6	960	62	4.1-5.3	32	R
	3/4	0.55	230	6.8	1050	52	1.5	8	1350	61	2.9-3.7	40	N
	1	0.75	230	8.2	1350	56	1.4	10.4	1800	58	2.2-2.8	48	N
	1-1/2	1.1	230	10.6	1880	59	1.3	13.1	2390	60	1.6-2.0	65.5	M
3 Wire	1/2	0.37	115	10	740	50	1.6	12	960	62	M 1.1-1.4 A 4.3-5.3	48	M
	1/2	0.37	230	5	740	50	1.6	6	960	62	M 4.1-5.3 A 18.0-21.9	23	M
	3/4	0.55	230	6.8	1050	52	1.5	8	1350	61	M 2.9-3.7 A 11.0-13.5	39	M
	1	0.75	230	8.2	1350	56	1.4	10.4	1800	58	M 2.2-2.8 A 10.2-12.6	42	L
	1-1/2	1.1	230	10	1800	61	1.3	11.5	2280	63	M 1.7-2.2 A 7.8-9.6	52	J
	2	1.5	230	10	2380	63	1.25	13.2	2800	67	M 1.8-2.5 A 5.4-7.0	50	G

M = Main Res. ( Yellow to Black)  
A = Aux. Res. ( Yellow to Red)

### 60HZ THREE PHASE MOTOR TABLE

	HP	KW	Voltage	Full Load			S.F.	Service Factor Load (Maximum Values)			Winding Res. Ohms	LR Amps	KVA Code
				Amps	Watts	%Eff F.L.		S.F. Amps	S.F. Watts	%Eff S.F.			
3 Wire	1/2	0.37	230	2.4	585	64	1.6	2.9	860	70	9.5-10.9	15.2	N
	1/2	0.37	460	1.2	585	64	1.6	1.5	860	70	38.4-44.1	7.6	N
	3/4	0.55	230	3.1	810	69	1.5	3.8	1150	73	6.8-7.8	21.4	N
	3/4	0.55	460	1.6	810	69	1.5	1.9	1150	73	27.2-30.9	10.7	N
	1	0.8	230	3.9	1070	70	1.4	4.7	1440	72	4.9-5.6	26.9	M
	1	0.75	460	2	1070	70	1.4	2.4	1440	72	19.9-23.0	13.5	M
	1-1/2	1.10	230	5	1460	76	1.3	5.9	1890	76	3.2-4.0	33.2	K
	1-1/2	1.10	460	2.5	1460	76	1.3	3.1	1890	76	13.0-16.0	16.6	K
	2	1.50	230	6.7	1960	76	1.25	8.1	2430	76	2.3-3.0	45	K
	2	1.50	460	3.4	1960	76	1.25	4.1	2430	76	9.2-12.0	22.5	K
	3	2.2	230	9.5	2920	77	1.15	10.9	3360	77	1.8-2.2	60.3	K
3	2.2	460	4.8	2920	77	1.15	5.5	3360	77	7.2-8.8	31	K	

### SINGLE PHASE MOTOR FUSE SIZING

		Fuse or Circuit Breakers Amp MAXIMUM PER NEC			
	HP	Voltage	Standard Fuse	Dual Element Time Delay Fuse	Circuit Breaker
2 WIRE	1/2	115	35	20	30
	1/2	230	20	10	15
	3/4	230	25	15	20
	1	230	30	20	30
	1-1/2	230	35	20	30
3 WIRE	1/2	115	35	20	30
	1/2	230	20	10	15
	3/4	230	25	15	20
	1	230	30	20	25
	1-1/2	230	35	20	30
	2	230	40	20	30

### THREE PHASE MOTOR FUSE SIZING

			Fuse or Circuit Breakers Amp MAXIMUM PER NEC		
	HP	Voltage	Standard Fuse	Dual Element Time Delay Fuse	Circuit Breaker
3 WIRE	1/2	230	8	4.5	6
	1/2	460	4	2.25	3
	3/4	230	10	5.6	8
	3/4	460	5	2.8	4
	1	230	15	7	10
	1	460	6	3.5	5
	1-1/2	230	15	9	15
	1-1/2	460	8	4.5	8
	2	230	25	12	20
	2	460	15	6	10
	3	230	30	17.5	25
	3	460	15	9	15





# 4" Submersible Motors

## MOTOR DATE CODES



### F&W DATE CODE EXPLANATION

**21 A K - 01 - 001**

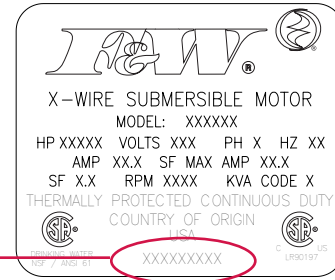
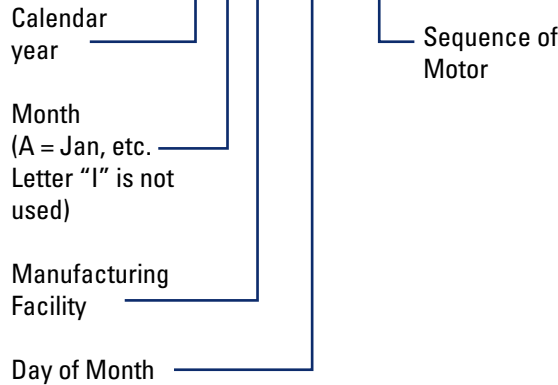

PATENT NO. 11,272,081

EQUIPPED WITH  
LIGHTNING/SURGE PROTECTORS

## GENERATOR SIZING

Careful consideration needs to be made when sizing a engine driven generator for use with a well pump. Generators need to be sized to supply a minimum of 65% of the rated motor voltage during motor starting to ensure sufficient starting torque.

The type of the generator makes a difference when selecting a generator to power a well pump. Two types of generators are available: Internally regulated and externally regulated. Internally regulated generators have an additional winding within the generator. The additional winding automatically adjusts the output voltage by monitoring the output current. The majority of generators on the market today are externally regulated. These generators use an external voltage regulator that monitors the output voltage. When a motor starts up and the voltage drops, the regulator boosts the output voltage of the generator.

When operating a pump with a generator, the generator needs to be started in advance of starting the pump motor. In addition, to help prevent motor bearing damage, stop the pump before turning off the generator.

The table below only represents typical minimum generator requirements for starting and running a submersible motor. Contact the generator manufacturer for detailed sizing considerations.

**⚠ WARNING:** Transfer switches are required when a generator is used as a back-up on power lines. Consult your power provider for proper use and approval.

## ENGINE DRIVEN GENERATORS

Motor HP Rating	Externally Regulated		Internally Regulated	
	KW	KVA	KW	KVA
1/2	2	2.5	1.5	1.9
3/4	3	3.8	2	2.5
1	4	5	2.5	3.2
1.5	5	6.3	3	3.8
2	7.5	9.4	4	5

Note: The table provided applies to 3-Wire motors.  
If sizing for 2-Wire motors, multiply the value shown by 1.5.

## BUCK-BOOST TRANSFORMERS

A buck-boost transformer is the ideal solution for changing line voltage by small amounts when the power available for a motor is not within the correct range. These transformers can be connected for a wide range of voltage combinations. The most common use is to buck (lower) or boost (raise) the supply voltage a small amount, usually 5 to 27%. When a buck-boost transformer has the primary and secondary windings connected as an autotransformer, only the secondary windings are transforming voltage and current. This is the reason buck-boost transformers can supply a load with a much larger KVA rating than the nameplate indicates. Tables published by transformer manufactures can provide a wide range of voltage change. The table provided is based on boosting voltage by 10% as recommended by F&W. It shows the minimum rating of KVA that the transformer needs as well as the common standard transformer KVA generally available.

Note: Contact transformer manufacturer for details and correct sizing when planning to raise or lower the voltage for a range other than the 10% boost listed.

Buck-Boost transformer Sizing (10% Boost)						
Motor HP	1/2	3/4	1	1.5	1.5 (2-wire)	2
Load KVA	1.38	1.84	2.40	2.65	3.01	3.04
Minimum Transformer KVA	0.14	0.19	0.24	0.27	0.31	0.31
Standard Transformer KVA	0.25	0.25	0.25	0.50	0.50	0.50



# 4" Submersible Motors

## CYCLING ON / OFF

Motor life can be reduced with excessive cycling of the pump due to the current in-rush at start up. Frequent starts increase motor temperature, create bearing and seal wear, and shaft spline fatigue. While typical residential cycling is estimated at 25 to 50 starts per 24 hour period, recommended maximum starts for longer life should not exceed 1 start per 5 minutes.

## SHAFT HEIGHT

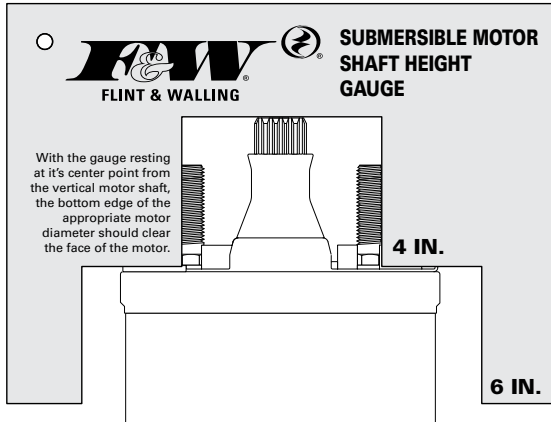

With the 024456 gauge resting at it's center point from the vertical motor shaft, the bottom edge of the appropriate motor diameter should clear the face of the motor.

## IDENTIFICATION OF CABLE COLOR

(Single Phase Only)

If the colors on the individual drop cables cannot be determined and the leads cannot be positively identified, proceed as follows:

1. Disconnect all three drop cables from the control box. For temporary identification, tie a numbered tag to each cable (1, 2, 3).
2. Using an ohmmeter, check the resistance between cables as follows:

Unknown Value	Known Value
Cable 1 to Cable 2	Lowest - Black to Yellow
Cable 1 to Cable 3	Intermed. - Red to Yellow
Cable 2 to Cable 3	Highest - Black to Red

NOTE: The "yellow" cable is giving the lowest and intermediate readings and the "red" cable gives highest and intermediate readings.

Example:

- 1 to 2 gives 7 ohms (highest reading)
- 1 to 3 gives 5 ohms (intermediate reading)
- 2 to 3 gives 2 ohms (lowest reading)
- Cable 3 gave both intermediate and lowest reading
- Cable 3 is the yellow cable
- Cable 1 gave both highest and intermediate readings
- Cable 1 is the red cable
- Cable 2 is the black cable

The actual ohm values are not important. The method works regardless of the actual ohm readings; what matters is which reading is highest, which intermediate, and which lowest.



# 4" Submersible Motors

## SINGLE PHASE CONTROL BOX CHECKING AND REPAIRING PROCEDURES

**CAUTION: Turn power off and discharge capacitors before using ohmmeter.**

### TEST PROCEDURE

General Procedures	Disconnect line. Inspect for damaged or burned parts, loose connections, etc. Check for mis-connections using diagram in control box. If problem has not been found, check motor per Motor Data Chart and control box as indicated below.
Use of Ohmmeter	Use a calibrated or certified digital multimeter.
Ground (Insulation Resistance) Test	Multimeter selected to highest OHM meter scale. Terminal connections: Multimeter lead to "ground" terminal on control box and touch other lead to each of the other terminals on terminal board. Multimeter reading should indicate ( $\infty$ ) or max open circuit limits.
Overload Protector	Multimeter selected to lowest OHM meter scale. Terminal connections: Connect one multimeter lead to Terminal Black and other lead to L1. Multimeter reading: Should be 0 to 0.5 ohms maximum.
Capacitor Tests	<b>Start Capacitor</b> Multimeter selected to 10k – 20k Ohm meter scale. Terminal Connections: One multimeter lead to relay terminal #1 and the other to black terminal on the terminal board. Ohm reading: The multimeter will briefly read a low resistance and climb back to infinity/max open circuit reading. If reading is not as above, the capacitor is likely shorted or open and needs to be replaced. <b>Run Capacitor</b> Multimeter selected to 10k – 20k Ohm meter scale. Disconnect the Red lead from the run capacitor terminal. Terminal Connections: One multimeter lead to the terminal on the capacitor that the red lead was connected to and the other to black terminal on the terminal board. Ohm reading: The multimeter will briefly read a low resistance and climb back to the infinity/max open circuit reading. If reading is not as above the capacitor is likely shorted or open and needs to be replaced. Caution: The tests in this guide for capacitors and relays should be considered indicative, but not irrefutable. A capacitor for example may not show as open or shorted, but may have lost some of its capacitance and may no longer be capable of performing its purpose.
Relay Coil Test (potential relays only)	Multimeter selected to 10k – 20k Ohm meter scale. Terminal Connections: Connect one multimeter lead to #2 and the other to #5 on the relay. For 230 Volt boxes, the meter should read 4.5-7.0 K Ohms. For 115 Volt boxes, the meter should read 2.9 4.9 K Ohms.
Relay Contact Test	Multimeter selected to lowest Ohm meter scale. Terminal Connections: Connect one multimeter lead to #1 and the other to #2 on the relay. The meter should read Zero ohms.

### MULTIMETER TESTS

#### Insulation and Continuity Test

1. This test is recommended when the splicing is complete and pump is being test run in a tank of water. This test can be repeated after installation in well, but before the final electrical hook-up is made to the control box or pressure switch.
2. Confirm multimeter ohmmeter function by clipping the leads together and verifying resistance readings  $<0.2\Omega$
3. Clip one multimeter lead to bare cable end.
4. Clip the other lead to motor ground wire with pump and cable submerged.
5. A reading of less than 1,000,000 ohms indicates that cable or splice is grounded. Slowly raise cable from the water at the multimeter end. When trouble spot moves clear of the water, OHM reading will increase towards ( $\infty$ ) or max open reading of multimeter. In an old installation with the pump in the well, a reading of 20,000 ohms or less indicates a breakdown in the insulation; in this case pull the pump.

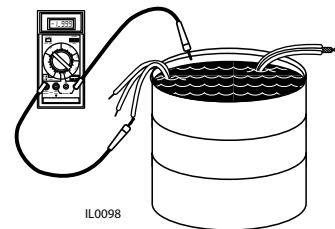

IL0098

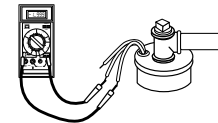

IL0099



# 4" Submersible Motors

## TROUBLESHOOTING CHART

Symptom	Possible Cause(s)	Corrective Action
Circuit breaker trips or fuses blow when motor starts.	1. Incorrect voltage	1. Contact power company if voltage is incorrect after first checking for correct wire size. See Wire Size Chart.
	2. Incorrect fuses or circuit breaker.	2. Replace with correctly sized components.
	3. Defective pressure switch	3. Replace pressure switch or clean contacts.
	4. Control box malfunction	4. Correct faulty wiring or tighten loose contacts.
	5. Bound pump	5. Sand bound pump can sometimes be corrected by temporarily reversing black and red leads in control box then returning to normal. If pump does not rotate freely, it must be pulled and cleaned or realigned and the well condition corrected.
	6. Defective cable or motor winding	6. The pump must be pulled and the cable disconnected and inspected. Damaged cable should be correctly spliced or replaced. If cable is good, the motor winding is grounded
	7. Shorted or open motor winding	7. The pump must be pulled and motor or drop cable repaired or replaced.
Motor runs but circuit breaker, fuses or motor overload trips.	1. Incorrect voltage	1. Contact power company.
	2. Overheated protectors	2. Shade box, provide ventilation or move box away from heat source.
	3. Improperly wired control box	3. Confirm motor and line connections.
	4. Defective motor or cable	4. If ground, short or open circuit is indicated pump must be pulled for repair.
	5. Defective pump	5. Pull pump, clean and repair to ensure pump staging is free of excess sand or debris.
Motor does not start and circuit breaker or fuses not tripped.	1. No power	1. Replace fuses or reset circuit breaker. Contact power company if no power is reaching box.
	2. Defective pressure switch	2. Clean contact points or replace switch.
	3. Defective wiring	3. Correct faulty wiring or connections/splices.
Pump runs, but delivers little or no water.	1. Air locked pump	1. Not enough water over pump. Raise and lower the pump at a fast rate to purge air from pump body.
	2. Low water level in well	2. Throttle pump delivery through restricting valve. Lower pump setting if depth of well is adequate.
	3. Check valve stuck or installed improperly	3. Replace or reinstall properly, ensure water check valve arrow oriented with flow.
	4. Leak in drop pipe	4. Raise pipe, check for leak and replace damaged section.
	5. Pump screen blocked	5. Clean screen and reset at less depth. It may be necessary to clean well.
	6. Worn pump	6. Pull pump and replace staging or pump end.
Pump keeps running	1. Pressure switch	1. Clean points or replace switch. Verify pressure switch setting and function.
	2. Low level well	2. Throttle pump output or reset pump to lower level. Do not lower if sand may clog pump.
	3. Leak in system	3. Replace damaged section. Replace all piping and joints to eliminate leaks.
	4. Misapplied pump	4. Verify pump depth/static water level vs. pump performance curve. For guidance, contact Tech Support at 1-800-742-5044.
Pump starts too often	1. Pressure switch	1. Reset limits or replace switch.
	2. Leak in system	2. Repair or replace tank or pipes.
	3. Check valve	3. Replace if column of water leaking by check valve.
	4. Water-logged tank	4. Replace tank.
	5. Pressure tank too small	5. Install larger tank.

